

UNITED STATES DISTRICT COURT  
FOR THE DISTRICT OF NEW HAMPSHIRE

AntennaSys, Inc.

v.

Case No. 17-cv-105-PB  
Opinion No. 2018 DNH 259

AQYR Technologies, Inc. and  
Windmill International, Inc.

MEMORANDUM AND ORDER

AntennaSys, Inc., claims that AQYR Technologies International, Inc., has infringed [U.S. Patent No. 7,432,868 B2](#) ("['868 Patent](#)"). In this Memorandum and Order, I construe several disputed patent terms on which the infringement claim is based.

**I. Background**

**A. Introduction**

The '868 Patent claims a portable antenna positioner apparatus and method for communicating with satellites. The patent's co-inventors each assigned their undivided one half interests in the patent to their respective employers, AntennaSys and Windmill International, Inc. AntennaSys and Windmill, in turn, entered into a License Agreement ("[Agreement](#)") that granted Windmill the exclusive right to exploit the '868 Patent under the terms and conditions of the Agreement. The Agreement obligates Windmill to prosecute

infringement claims against third parties but permits AntennaSys to step in if Windmill fails to act within the time limits specified in the Agreement.

AntennaSys claims that AQYR, a wholly owned subsidiary of Windmill, is selling several products that infringe the '868 Patent. It further asserts that it has standing to sue for infringement because Windmill has failed to enforce the '868 Patent against its subsidiary.<sup>1</sup>

## **B. Prior Art**

When the '868 Patent was approved, "[e]xisting antenna positioners [were] heavy structures that [were] bulky and require[d] many workers to manually setup (sic) and initially orient." '868 Patent at 1:37-39. Some systems were so heavy that multiple workers were required to lift a disassembled apparatus. See '868 Patent at 1:44-47. Others were mounted on trucks and were difficult to ship by airplane. See '868 Patent at 1:39-41. The '868 Patent seeks to address these deficiencies by patenting a "compact, lightweight, portable self-aligning

---

<sup>1</sup> AntennaSys has also brought other claims against Windmill and AQYR that this Memorandum and Order does not address. Although the infringement claim is asserted only against AQYR, Windmill shares an interest with its subsidiary in supporting claim construction. Accordingly, in the remainder of this Memorandum and Order, I use Windmill to refer to Windmill and AQYR collectively.

antenna positioner that [could be] easily moved by a single user and allowed for rapid setup and alignment." '868 Patent at 1:20-25.

### C. The Patent

AntennaSys's infringement claim is focused principally on Claims 1 and 6 of the '868 Patent. I reproduce both claims below and highlight the terms that are in dispute.

#### Claim 1

What is claimed is:

1. A portable antenna positioner comprising:  
an antenna with a centrally located pivot point;  
an elevation motor coupled with said antenna wherein  
said antenna rotates about said centrally located  
pivot point in elevation when moved by said  
elevation motor;  
at least one positioning arm coupled with said  
elevation motor;  
an azimuth motor coupled with said at least one  
positioning arm;  
a positioner base coupled with said azimuth motor  
wherein said positioner base houses a computer  
configured to control said antenna; and,  
said antenna, said elevation motor, said at least one  
positioning arm, said azimuth motor and said  
positioning base configured to be stowed and  
deployed and carried by a single person.

#### Claim 6

6. A method for utilizing a portable antenna positioner comprising:  
coupling an antenna with an elevation motor wherein  
said antenna comprises a centrally located pivot  
point and wherein said antenna is configured to  
rotate about said centrally located pivot point in  
elevation when moved by said elevation motor;

coupling at least one positioning arm with said an elevation motor;  
coupling said at least one positioning arm with an azimuth;  
coupling said azimuth motor with a positioner base;  
and,  
delivering said antenna, said elevation motor, said at least one positioning arm, said azimuth motor wherein said antenna is configured to be stowed and deployed and wherein said antenna, said elevation motor, said at least one positioning arm and said azimuth motor are configured to be carried by a single person.

## II. Legal Standard

"[T]he claims of a patent define the invention to which the patentee is entitled the right to exclude." [Phillips v. AWH Corp.](#), 415 F.3d 1303, 1312 (Fed. Cir. 2005) (en banc) (citation omitted). As a result, "a claim construction analysis must begin and remain centered on the claim language itself, for it is the language the patentee has chosen to 'particularly point[] out and distinctly claim[] the subject matter which the patentee regards as his invention.'" [Innova/Pure Water, Inc. v. Safari Water Filtration Sys., Inc.](#), 381 F.3d 1111, 1116 (Fed. Cir. 2004)(internal citation omitted). The words of a patent claim "are generally given their ordinary and customary meaning." [Phillips](#), 415 F.3d at 1312 (internal quotation marks and citation omitted). The "ordinary and customary meaning of a claim term is the meaning that the term would have to a person

of ordinary skill in the art in question at the time of the invention....” [Id.](#) at 1313.

I must construe claims “in light of the appropriate context in which the claim term is used.” [Aventis Pharm. Inc. v. Amino Chems. Ltd.](#), 715 F.3d 1363, 1373 (Fed. Cir. 2013). Thus, although the written description and other portions of the specification may contextualize a term, “they cannot be used to narrow a claim term to deviate from the plain and ordinary meaning unless the inventor” intended to disclaim or disavow the claim scope. [Id.](#) (citing [Toro Co. v. White Consol. Indus., Inc.](#), 199 F.3d 1295, 1316 (Fed. Cir. 1999)). When construing a disputed claim term, other claims made in the patent can be “valuable sources of enlightenment as to the meaning of a claim term.” [Phillips](#), 415 F.3d at 1314.

Patent claims are not construed in the abstract, but rather “in the context in which the term was presented and used by the patentee, as it would have been understood by a person of ordinary skill in the field of the invention.” [Fenner Invs., Ltd. v. Cellco P’ship](#), 778 F.3d 1320, 1322-23 (Fed. Cir. 2015). The specification “is always highly relevant to the claim construction analysis” and is usually “the single best guide to the meaning of a disputed term.” [WesternGeco LLC v. ION Geophysical Corp.](#), 889 F.3d 1308, 1323 (Fed. Cir. 2018) (quoting

Phillips, 889 F.3d at 1315). The prosecution history and patent specification constitute intrinsic evidence and deserve priority in claim construction. Id. at 1323 (citation omitted). In the rare event that analysis of the intrinsic evidence does not resolve an ambiguity in a disputed claim term, I may turn to extrinsic evidence, such as inventor and expert testimony, treatises and technical writings. Phillips, 415 F.3d at 1317. Although extrinsic evidence may be helpful in construing claims, the intrinsic evidence is afforded the greatest weight in determining what a person of ordinary skill would have understood a claim to mean. V-Formation, Inc. v. Benetton Grp. SpA, 401 F.3d 1307, 1310-11 (Fed. Cir. 2005).

### III. Analysis

The parties have asked me to construe seven groups of terms. Four of these groups do not require construction, and one term in the fifth group has a plain but not commonly understood meaning that I will construe for the assistance of the jury. I devote the remainder of the Memorandum and Order to the two groups of terms that lie at the heart of this dispute.

#### A. Terms 1-4

##### 1. "Antenna"

#### Proposed constructions:

|            |   |
|------------|---|
| AntennaSys | Device connected to a receiver/transmitter to communicate with satellites |
|------------|---|

|          |  |
|----------|--|
| Windmill | Plain and ordinary meaning. To the extent that meaning needs to be defined:<br><br>A structure for receiving or transmitting electromagnetic signals |
|----------|--|

## 2. "Pivot Point"

### Proposed constructions:

|            |  |
|------------|--|
| AntennaSys | A location about which an object rotates   |
| Windmill   | Plain and ordinary meaning. To the extent that meaning needs to be defined:<br><br>The location at which something turns or oscillates |

## 3. "Elevation" and "Elevation Motor"

### Proposed constructions:

|            |   |
|------------|---|
| AntennaSys | <b>elevation</b> - an angle up or down from the horizon<br><br><b>elevation motor</b> - mechanism to position the antenna to an angle up or down from the horizon   |
| Windmill   | Plain and ordinary meaning. To the extent that meaning needs to be defined:<br><br><b>elevation</b> - process of bringing something to a higher position<br><br><b>motor</b> - a machine used to transform power from some other form into mechanical motion to elevate a corresponding structure |

## 4. "Positioning Arm" and "Positioning Base"

### Proposed constructions:

|            |   |
|------------|---|
| AntennaSys | <b>positioning arm</b> - structure to connect a base to an antenna for the purpose of positioning the antenna |
|------------|---|

|          |  |
|----------|--|
|          | <b>positioning base</b> - a structure that houses electronic components  |
| Windmill | Plain and ordinary meaning. To the extent that meaning needs to be defined:<br><br><b>arm</b> - a thing resembling an arm in branching from a main stem<br><br><b>positioning</b> - the action of manipulating an object in relation to another object or for a certain configuration<br><br><b>base</b> - foundation or part upon which an object rests<br><br><b>positioning arm</b> - a thing resembling an arm that is used to manipulate an object in relation to another object or for a certain configuration |

The point of claim construction is to resolve "disputed meanings and technical scope, to clarify and when necessary to explain what the patentee covered by its claims." [U.S. Surgical Corp. v. Ethicon, Inc., 103 F.3d 1554, 1568 \(Fed. Cir. 1997\)](#).

In the present case, all of the disputed claim terms have plain and ordinary meanings; neither party has pointed to any persuasive evidence to suggest that a specialized meaning was intended. The parties have also failed to point to any meaningful differences between their proposed constructions. Nor have they persuaded me that the definitions they propose amount to anything more than the type of "meaningless verbiage" that should not be the end product of an exercise in claim construction. See [Harris Corp. v. IXYS Corp, 114 F.3d 1149,](#)



1152 (Fed. Cir. 1997). I, therefore, decline to construe the first four groups of disputed claim terms.<sup>2</sup>

**B. Term 5 - "Azimuth Motor"**

**Proposed constructions:**

|            |   |
|------------|---|
| AntennaSys | Mechanism to position the antenna left or right along the horizon |
| Windmill   | Motor that rotates positioning arm from side to side              |

The parties' proposed constructions of "azimuth motor" do not differ materially and neither party has pointed to any persuasive intrinsic or extrinsic evidence that supports one of the proposed constructions over the other. Nevertheless, because some members of the jury who may be called upon to decide this case may not be familiar with the term "azimuth," I will give that term its usual meaning and construe "azimuth motor" to mean "a motor to position the antenna left or right along the horizon."

---

<sup>2</sup> I will, of course, reserve the right to reassess the situation later in the litigation if either party is able to persuade me that I can assist the parties in resolving their dispute by further defining a disputed term.

C. Term 6 - "an antenna with a centrally located pivot point" and "said antenna comprises a centrally located pivot point"

Proposed constructions:

|            |   |
|------------|---|
| AntennaSys | <p><b>centrally located</b> - a location closer to the center than the perimeter of the antenna; not necessarily on the antenna</p> <p>See above for "<b>antenna</b>" and "<b>pivot point.</b>"</p> |
| Windmill   | An antenna that pivots from its center point  |

The parties disagree as to whether the term "centrally located pivot point" describes a pivot point located at the precise center of the antenna, as Windmill claims, or whether, as AntennaSys argues, the pivot point may be located at any point that is closer to the center of the antenna than the perimeter.

To support its view that the pivot point must lie at the center point of the antenna, Windmill relies primarily on the doctrine of prosecution history disclaimer. Under this doctrine, a patentee may not recapture a meaning for a claim term that the patentee disavowed in order to obtain the patent. Mass. Inst. of Tech. v. Shire Pharm., Inc., 8339 F.3d 1111, 1119 (Fed. Cir. 2016). To disclaim a proposed meaning, the evidence of repudiation must be "clear and unmistakable." 3M Innovative

[Props. Co. v. Tredegar Corp.](#), 725 F.3d 1315, 1325 (Fed. Cir. 2013). I see no such disclaimer in this case.

The original application for what became the '868 Patent claimed in pertinent part "an antenna with a centrally located pivot point" without specifying that the antenna must rotate about the pivot point in elevation. See Doc. No. 33-10 at 127. Instead, it limited what was claimed to a device with "an elevation motor coupled with said antenna wherein said antenna may rotate up to 180 degrees in elevation." See [id.](#)

The patent examiner originally rejected the claim on the ground that it was obvious in light of Wise et al, U.S. Application No. 22110046258 (Wise), which also taught a portable antenna positioner. See Doc. No. 33-10 at 65. In reaching this conclusion, the examiner noted that, like Wise, the proposed patent claimed a device with a centrally located pivot point. He then went on to note that although Wise did not expressly describe an antenna that was rotatable 180 degrees in elevation, it nevertheless was obvious in light of Wise that an antenna positioner could have this capacity because Wise teaches that "the antenna support member is pivotable between a first position and a second position at a selected angle to establish elevational alignment with the satellite . . . ." (emphasis in original). See [id.](#)

The patentees responded by doing two things. First, they amended their claim in pertinent part to delete the 180 degree rotational limitation and instead claimed "an elevation motor coupled with said antenna wherein said antenna rotates about said centrally located pivot point." See Doc. No. 33-10 at 50. Second, they directly addressed the examiner's obviousness argument by pointing to Figure 3 in Wise and noting that "[t]he antenna of Wise '258 does not pivot at the center of the antenna but rather pivots on one side of the antenna. This limits the range that the antenna may face from completely straight up to a horizon when fully extended for example." See Doc. No. 33-10 at 56.

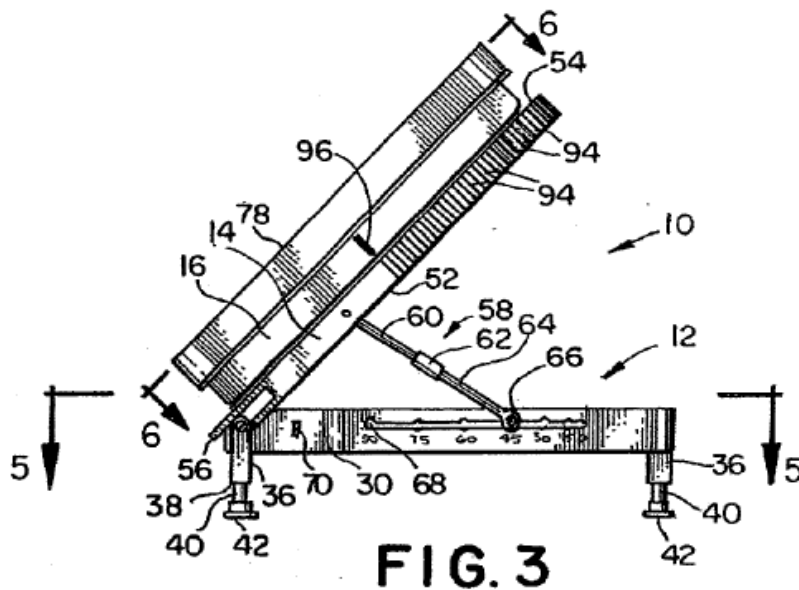

The patentees' amendment and argument did not initially persuade the examiner, who responded by stating, "[a]pplicant argues that the antenna of Wise does not pivot at the center of the antenna, examiner respectfully disagrees. Wise does teach in Figure 7 the antenna 20 rotating about its center 80. Since Wise does show all claimed structure, the 102 rejection is proper." See Doc. No. 33-10 at 44.

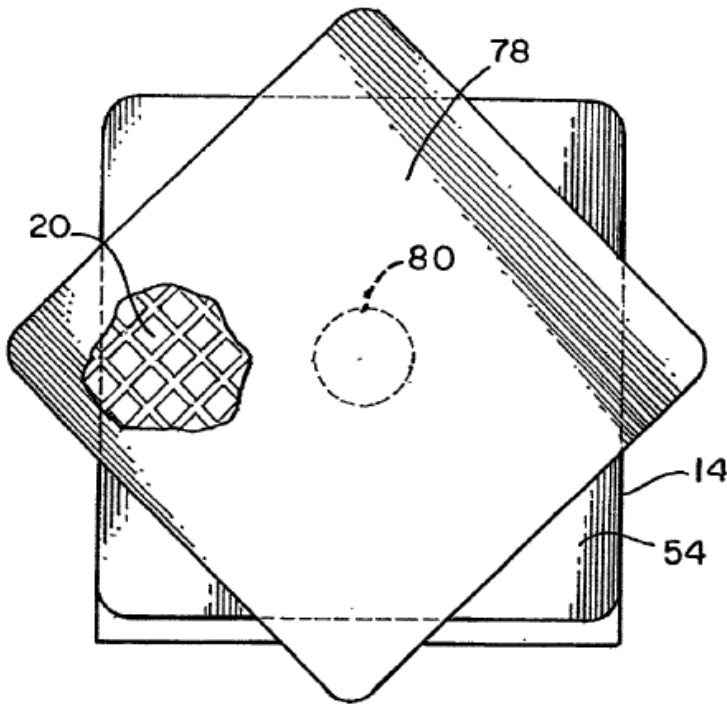

**FIG. 7**

The patentees did not give up when their amended claim was rejected. Instead, they amended the claim again to cover "an elevation motor coupled with said antenna wherein said antenna rotates about said pivot point in elevation when moved by said

elevation motor." See Doc. No. 33-10 at 31. They also explained to the examiner that,

Wise moves about a centrally located pivot point in the polarization axis (i.e., orthogonal to the elevation axis) and NOT when moved by the elevation motor. Wise does not rotate about the centrally located pivot point in elevation as the pivot point in elevation for Wise is located at the junction of antenna support member 114 and base unit housing 118, i.e., at the side of the antenna.

Doc. No. 33-10 at 36 (emphases in original).

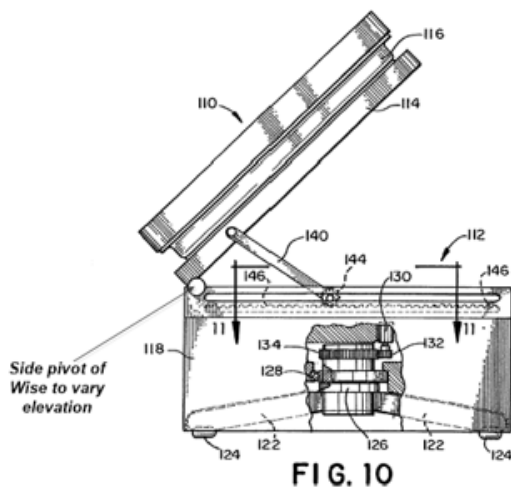

The patentee's amendment and explanation apparently satisfied the examiner, as he issued the patent as amended and ultimately concluded that "Wise et al does not teach an elevation motor coupled with an antenna wherein the antenna rotates about the centrally located pivot point in elevation when moved by the elevation motor." See Doc. No. 33-10 at 16.

For reasons that I do not quite understand, Windmill contends that this prosecution history demonstrates that the patentees disclaimed any meaning for a "centrally located pivot point" other than one that specifies a location at the center point of the antenna. See Defendants' Opening Claim Construction Brief, Doc. No. 33 at 21-25. This contention is plainly wrong. Instead, the patentees overcame the examiner's initial conclusion that their invention was obvious in light of Wise by amending the patent to make it clear that, unlike Wise, which claimed an antenna positioner with an elevation pivot point at the side of the device, their invention claimed a positioner with a centrally located elevation pivot point. At no point during the prosecution of their claims did the patentees ever suggest that the elevation pivot point for their device must be located at the center point of the antenna. Accordingly, I reject Windmill's prosecution disclaimer argument.<sup>3</sup>

---

<sup>3</sup> Windmill also briefly argues that its proposed construction must be adopted because the alternative construction proposed by AntennaSys would render the challenged claims indefinite. I reject this argument. AntennaSys's proposed construction is not indefinite because a determination as to whether a pivot point is centrally located under its definition can be made objectively by simple measurement.

AntennaSys points to several types of intrinsic and extrinsic evidence to support its proposed construction but what I ultimately find persuasive is its contention that the patent's contextual use of the term "centrally" plainly describes a pivot point that is located closer to the center than the perimeter of the antenna. Windmill has failed to identify any persuasive evidence to support its alternative construction. Accordingly, I agree with AntennaSys that a pivot point is centrally located under the '868 Patent if its "location is closer to the center than the perimeter of the antenna; not necessarily on the antenna."<sup>4</sup>

**D. Term 7 - "configured to be stowed and deployed and carried by a single person," "configured to be stowed and deployed," and "configured to be carried by a single person"**

"Term 7" as presented by the parties includes three relevant terms that warrant construction: "configured to be stowed and deployed," "carried" and "single person." I will handle each in turn.

---

<sup>4</sup> AntennaSys argues that the pivot point need not be on the antenna itself and it cites to an embodiment that appears to depict a pivot point located on the positioning arm rather than the antenna itself. Windmill has not challenged AntennaSys's proposed construction on this point. Accordingly, I adopt AntennaSys's proposed construction.



## 1. "Configured to be Stowed and Deployed"

### Proposed constructions:

|            |  |
|------------|--|
| AntennaSys | <b>stowed and deployed</b> - term that refers to two states for the portable antenna positioner: One to be stored in an inactive position, and another into an active operating position.  |
| Windmill   | made so that, without needing to remove any of these components or parts, the components can be folded into themselves for storage or carrying as a self-contained unit as well as unfolded and positioned for use from a self-contained unit "by a single person" |

The parties' disagreement over the meaning of "stowed and deployed" is focused on whether the term "stowed" encompasses any device that can be stored in an inactive position, as AntennaSys argues, or whether it requires a device that is stored by folding into itself, as Windmill contends. After considering all the evidence that bears on the issue, I conclude that Windmill has the better argument.

In a case like this, where the claim language is not dispositive, the meaning of a disputed claim term can often be discerned by reviewing the patent's specification. When undertaking this task, however, a court must be careful not to cross the "fine line" that separates a proper use of the specification as a source of meaning from an improper use of the specification to read into a claim a limitation that it does not

contain. [Liebel-Flarsheim Co. v. Medrad, Inc.](#), 358 F.3d 898, 904 (Fed. Cir. 2004).

In the present case, the specification repeatedly, and unambiguously, supports Windmill's narrower reading of "stowed and deployed." First, the patent supports this construction because it states that one of the deficiencies with the prior art was that existing systems "require over a half dozen storage containers that each require one or more workers to lift" whereas the patent notes that the described invention "has no loose parts and requires no tools." '868 Patent at 1:44-46; '868 Patent at 7:23. Second, the specification repeatedly describes the invention as "collapsible" without ever suggesting that it could also be stowed in a disassembled state. See, e.g., '868 Patent at 1:54-55 ("By collapsing the antenna positioner, it may be readily carried by hand or shipped in a compact container."); '868 Patent at 7:45-46 ("FIG. 5 shows a perspective view of an embodiment of the invention in the collapsed position."); '868 Patent at 8:3-4 ("self contained (sic) lightweight, collapsible and rugged antenna positioner"). Finally, the only figures in the patent that depict embodiments of the invention in a stowed state all depict a device that is stowed by collapsing onto itself. See '868 Patent at 7:46-47 ("FIG. 5 shows a perspective view of an embodiment of the

invention in the stowed position."); '868 Patent at 7:48-49 ("FIG. 6 shows an isometric view of an embodiment of the invention in the collapsed position."); '868 Patent at 7:50-51 ("FIG. 7 shows an isometric view of the bottom of an embodiment of the invention in the stowed position."). Read together, these references clearly demonstrate the patentees' intention to claim an antenna positioner that is stowed by folding into itself.

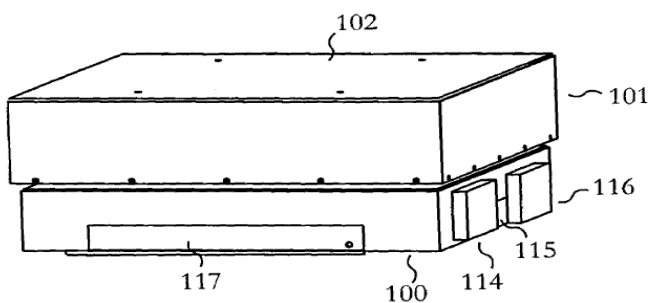
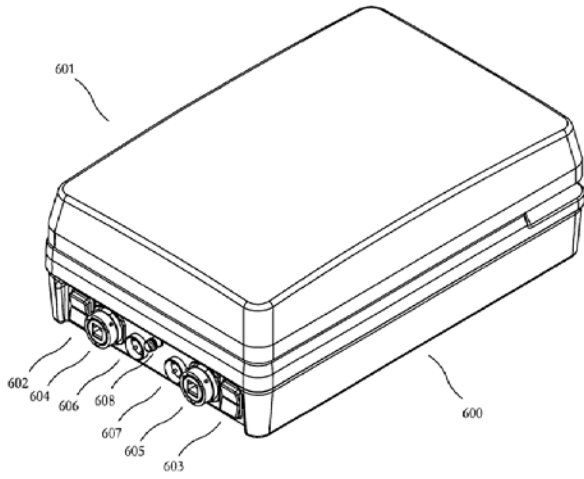

Fig. 5

Fig. 6



**Fig. 6**

Fig. 7

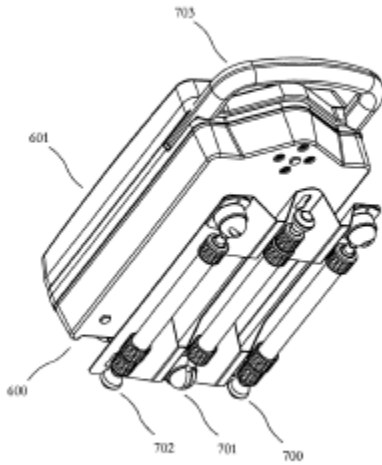

**Fig. 7**

In contrast to the strong evidence supporting Windmill's proposed construction, AntennaSys cites only to Figure 11 as a source of intrinsic evidence to support its contention that patented invention encompasses antenna positioners that can be stowed by disassembly into component parts. But his figure has no bearing on the present dispute because it is merely a flow chart that depicts the manufacturing process for one or more embodiments of the invention. '868 Patent at 16:10-14.

**Figure 11**

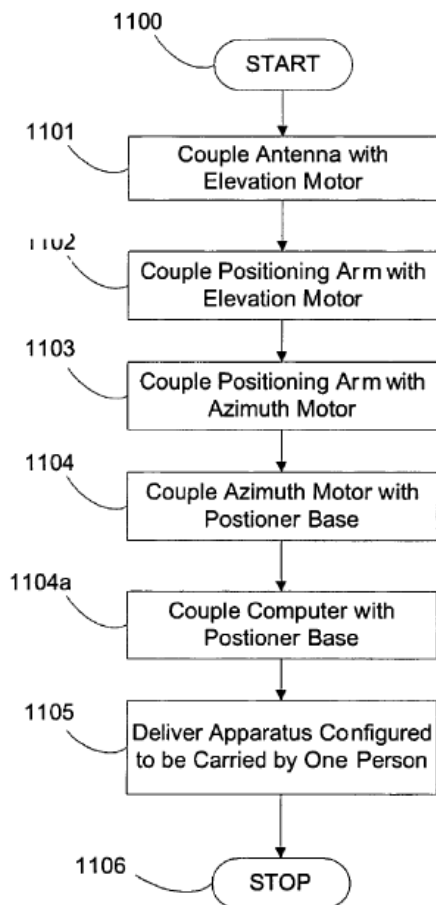

The Federal Circuit's decision in Retractable Technologies provides a helpful analogue to this dispute. See Retractable Techs., Inc. v. Becton, Dickinson & Co., 653 F.3d 1296, 1305 (Fed. Cir. 2011), reh'g denied and reh'g en banc denied 659 F.3d 1369 (2011). In that case, the Federal Circuit reversed a district court order construing a patent for retractable medical syringes. See id. at 1298. The circuit held that the claimed "body" of the patented syringe must be limited to a one-piece structure even though the claim language had no such limitation. It observed that the specification distinguished syringes comprised of multiple pieces, referenced one-piece syringes at multiple places in the specification, and included no embodiments contemplating a multi-piece body. See id. at 1304-1305. Accordingly, the court explained that

While the claims leave open the possibility that the recited "body" may encompass a syringe composed of more than one piece, the specifications tell us otherwise. They expressly recite that "the invention" has a body constructed as a single structure, expressly distinguish the invention from the prior art based on this feature, and only disclose[s] embodiments that are expressly limited to having a body that is a single piece.

Id. at 1305.

So too here. Therefore, I construe the term "configured to be stowed and deployed" to mean "made so that the components can

be collapsed into themselves for storage or carrying as a self-contained unit and unfolded for use."

## 2. "Carried"

### Proposed constructions:

|            |   |
|------------|---|
| AntennaSys | <b>carried by</b> - Plain and ordinary meaning. In the alternative: Lifted and moved by a single person-using only their own physical abilities-from one place to another   |
| Windmill   | <b>carried</b> - Transported on one's person<br><br>"The term 'carried' cannot include the concept of a person using an external means to take the weight of the antenna positioner off of that person, like a dolly or rolling suitcase, etc." |

At the Markman hearing, I indicated that a construction of "carried" that would include an operator using a dolly or wagon would be problematic. The parties have since submitted supplemental briefing on the term.

At his deposition, Dr. Shina, the expert for AntennaSys, stated that his definition was broad enough to include a "person using a mechanical device such as a dolly or a truck or an external mechanical device . . . [a]s long as the person is the only person doing it that does not require the assistance of another person." Doc. No. 33-5 at 128:5-10. According to AntennaSys, Shina was stating that using a dolly was not excluded, so long as the person could carry it afterwards. See Hearing Transcript at 91. In any event, I conclude that using a

mechanical device to transport the invention would contravene the plain and ordinary meaning of the word "carried."

As both parties agree, the idea of "carrying" in the context of this case includes a requirement that the "carrier" bears the entire weight of the object on herself. It may be carried by handles, or in a backpack, or clutched in one's arms. But the use of a dolly, truck, or rolling device would not constitute carrying.

Windmill's proposed construction, "transported on one's person," relies on an inapposite usage. As the dictionary it cites notes, that usage is relevant when one asks, "Do you carry a watch?" See Doc. No. 46-4, The Concise Oxford Dictionary of Current English 200 (9th Ed. 1995). We are concerned here, by contrast, with the idea of "carrying from place to place." The proposal by AntennaSys, "Lifted and moved by a single person - using only their own physical abilities - from one place to another," is closer to the mark. Because, however, the proposed definition does not convey the idea of the carrier bearing the entire weight of the device, I will add that requirement to my construction.

I construe the term "carried" to mean: "lifted and moved from one place to another by a single person bearing the entire weight of the object." The term does not include the concept of



a person using an external means to take the weight off of that person, such as by using a dolly or a rolling suitcase.

### 3. "Single Person"

#### Proposed construction:

|            |  |
|------------|--|
| AntennaSys | <b>a single person</b> - an individual trained and responsible for stowing and deploying antennas in remote locations. |
| Windmill   | Indefinite, due to term "single person," which is a variable lacking any description in the specification.             |

AntennaSys's proposed construction will benefit the jury and is appropriately limited. The patent notes that the device was developed with aid from the United States military. See '868 Patent at 1:13-14. Doctor Shina's unrebutted expert report indicates that a person of ordinary skill in the art would understand "single person" to refer to "an individual trained and responsible for stowing and deploying antennas in remote locations." See Doc. No. 33-6 at 4. Whether this construction leaves the claims invalid, as Windmill argues, is an issue that I will address, if necessary, at a later point in the proceedings.

The term "single person" will be construed to mean "an individual trained and responsible for stowing and deploying antennas in remote locations."

#### IV. Conclusion

For the foregoing reasons, with respect to United States Patent No. 7,432,868:

- A) "antenna" is accorded its plain and ordinary meaning;
- B) "pivot point" is accorded its plain and ordinary meaning;
- C) "elevation" and "elevation motor" are accorded their plain and ordinary meanings;

- D) "position arm" and "positioning base" are accorded their plain and ordinary meanings;

- E) "azimuth motor" means:

**"a motor to position the antenna left or right along the horizon;"**

- F) "an antenna with a centrally located pivot point" and "said antenna comprises a centrally located pivot point" mean:

**"a location closer to the center than the perimeter of the antenna; not necessarily on the antenna;"**

- G) "configured to be stowed and deployed" means:

**"made so that the components can be collapsed into themselves for storage or carrying as a self-contained unit and unfolded for use;"**

- H) "carried by a single person" means:

**"lifted and moved from one place to another by a single person bearing the entire weight of the object;"**

I) "single person" means:

**"an individual trained and responsible for stowing and  
deploying antennas in remote locations."**

SO ORDERED.

/s/ Paul Barbadoro  
Paul Barbadoro  
United States District Judge

December 27, 2018

cc: Kathleen M. Mahan, Esq.  
Steven J. Grossman, Esq.  
Arnold Rosenblatt, Esq.  
David K. Pinsonneault, Esq.  
Eric G. J. Kaviar, Esq.  
Laura L. Carroll, Esq.