

UNITED STATES PATENT AND TRADEMARK OFFICE

---

BEFORE THE PATENT TRIAL AND APPEAL BOARD

---

FUJITSU SEMICONDUCTOR LIMITED, FUJITSU SEMICONDUCTOR AMERICA, INC., ADVANCED MICRO DEVICES, INC., RENESAS ELECTRONICS CORPORATION, RENESAS ELECTRONICS AMERICA, INC., GLOBALFOUNDRIES U.S., INC., GLOBALFOUNDRIES DRESDEN MODULE ONE LLC & CO. KG, GLOBALFOUNDRIES DRESDEN MODULE TWO LLC & CO. KG, TOSHIBA AMERICA ELECTRONIC COMPONENTS, INC., TOSHIBA AMERICA INC., TOSHIBA AMERICA INFORMATION SYSTEMS, INC., TOSHIBA CORPORATION, and THE GILLETTE COMPANY,  
Petitioner,

v.

ZOND, LLC,  
Patent Owner.

---

Case IPR2014-00802<sup>1</sup>  
Patent 7,811,421 B2

---

Before KEVIN F. TURNER, DEBRA K. STEPHENS, JONI Y. CHANG, SUSAN L. C. MITCHELL, and JENNIFER MEYER CHAGNON,  
*Administrative Patent Judges.*

Opinion for the Board filed by *Administrative Patent Judge Chagnon.*

Opinion Dissenting-in-Part filed by *Administrative Patent Judge Stephens.*

---

<sup>1</sup> Cases IPR2014-00848, IPR2014-00992, and IPR2014-01071 have been joined with the instant proceeding.

CHAGNON, *Administrative Patent Judge*.

FINAL WRITTEN DECISION  
*Inter Partes* Review  
35 U.S.C. § 318(a) and 37 C.F.R. § 42.73

I. INTRODUCTION

We have jurisdiction to hear this *inter partes* review under 35 U.S.C. § 6(c). This Final Written Decision is issued pursuant to 35 U.S.C. § 318(a) and 37 C.F.R. § 42.73. For the reasons discussed herein, we determine that Petitioner has shown by a preponderance of the evidence that claims 9, 14, 21, 26, 35 and 37 of U.S. Patent No. 7,811,421 B2 (Ex. 1201, “the ’421 patent”) are unpatentable.

A. *Procedural History*

Taiwan Semiconductor Manufacturing Company, Ltd. and TSMC North America Corp. (collectively, “TSMC”) filed a Petition (Paper 1, “Pet.”) seeking *inter partes* review of claims 9, 14, 21, 26, 35 and 37 (“the challenged claims”) of the ’421 patent. TSMC included a Declaration of Uwe Kortshagen, Ph.D. (Ex. 1202) to support its positions. Zond (“Patent Owner”) filed a Preliminary Response (Paper 8, “Prelim. Resp.”). Pursuant to 35 U.S.C. § 314(a), on October 6, 2014, we instituted an *inter partes* review of the challenged claims to determine if claims 9, 21, and 35 are unpatentable under 35 U.S.C. § 103 as obvious over the combination of

IPR2014-00802  
Patent 7,811,421 B2

Wang<sup>2</sup> and Kudryavtsev<sup>3</sup>; and if claims 14, 26, and 37 are unpatentable under 35 U.S.C. § 103 as obvious over the combination of Wang and Mozgrin Thesis.<sup>4</sup> Paper 9 (“Inst. Dec.”).

Subsequent to institution, we granted revised Motions for Joinder filed by other Petitioners listed in the Caption above, joining Cases IPR2014-00848, IPR2014-00992, and IPR2014-01071 with the instant trial (Papers 12, 13), and also granted a Joint Motion to Terminate with respect to TSMC (Paper 30).<sup>5</sup> Patent Owner filed a Patent Owner Response (Paper 27, “PO Resp.”), along with a Declaration of Larry D. Hartsough, Ph.D. (Ex. 2015) to support its positions. Petitioner filed a Reply (Paper 41, “Reply”) to the Patent Owner Response, along with a Declaration of Lawrence J. Overzet, Ph.D. (Ex. 1228). An oral hearing<sup>6</sup> was held on

---

<sup>2</sup> U.S. Patent No. 6,413,382 B1, issued July 2, 2002 (Ex. 1204).

<sup>3</sup> A.A. Kudryavtsev and V.N. Skerbov, *Ionization Relaxation in a Plasma Produced by a Pulsed Inert-Gas Discharge*, 28 SOV. PHYS. TECH. PHYS. 30–35 (Jan. 1983) (Ex. 1206).

<sup>4</sup> D.V. Mozgrin, *High-Current Low-Pressure Quasi-Stationary Discharge in a Magnetic Field: Experimental Research*, Thesis at Moscow Engineering Physics Institute (1994). Mozgrin Thesis is a Russian-language reference (Ex. 1208). Citations to Mozgrin Thesis herein are to the certified English-language translation submitted by Petitioner (Ex. 1207).

<sup>5</sup> We refer to the remaining parties, listed in the Caption above, collectively, as “Petitioner” throughout this Decision.

<sup>6</sup> The oral arguments for IPR2014-00781, IPR2014-00782, IPR2014-00800, IPR2014-00802, IPR2014-00805, IPR2014-01083, IPR2014-01086, and IPR2014-01087 were consolidated.

June 8, 2015. A transcript of the hearing is included in the record. Paper 49 (“Tr.”).

*B. Related Proceedings*

The parties indicate that the ’421 patent was asserted against Petitioner, as well as other defendants, in seven district court lawsuits pending in the District of Massachusetts. Pet. 1; Paper 5.

*C. The ’421 Patent*

The ’421 patent relates to a method and apparatus for high-deposition sputtering. Ex. 1201, Abstract. At the time of the invention, sputtering was a well-known technique for depositing films on semiconductor substrates. *Id.* at 1:15–16. As discussed in the ’421 patent, prior art magnetron sputtering systems deposited films having low uniformity, poor target utilization (the target material erodes in a non-uniform manner), and relatively low deposition rate (low amount of material deposited on the substrate per unit time). *Id.* at 1:63–2:14. The ’421 patent discloses that increasing the power applied to the plasma, in an attempt to increase the target utilization and sputtering yield, can also “increase[] the probability of establishing an undesirable electrical discharge (an electrical arc) in the process chamber.” *Id.* at 3:20–29.

The ’421 patent further discloses that using pulsed power can reduce the probability of establishing an electrical breakdown condition, but that large power pulses still can result in undesirable electrical discharges. *Id.* at 3:30–38. According to the ’421 patent, however, first forming a weakly-ionized plasma “substantially eliminates the probability of establishing a

breakdown condition in the chamber . . . when high-power pulses are applied between the cathode . . . and the anode.” *Id.* at 9:16–19. Once a weakly-ionized plasma is formed, high-power pulses are applied between the cathode and anode to generate a strongly-ionized plasma from the weakly-ionized plasma. *Id.* at 9:29–31, 10:8–9. The “probability of establishing a breakdown condition is substantially eliminated because the weakly-ionized plasma has a low-level of ionization that provides electrical conductivity through the plasma. This conductivity greatly reduces or prevents the possibility of a breakdown condition, even when high power is applied to the plasma.” *Id.* at 9:23–28.

*D. Illustrative Claim*

Each of the challenged claims depends from one of independent claims 1, 17, and 34, which are not challenged in the present Petition. Claim 1 is illustrative, and is reproduced as follows:

1. A sputtering source comprising:
  - a) a cathode assembly comprising a sputtering target that is positioned adjacent to an anode; and
  - b) a power supply that generates a voltage pulse between the anode and the cathode assembly that creates a weakly-ionized plasma and then a strongly-ionized plasma from the weakly-ionized plasma without an occurrence of arcing between the anode and the cathode assembly, an amplitude, a duration and a rise time of the voltage pulse being chosen to increase a density of ions in the strongly-ionized plasma.

Ex. 1201, 22:14–24.

## II. ANALYSIS

### A. *Claim Construction*

In an *inter partes* review, claim terms in an unexpired patent are given their broadest reasonable construction in light of the specification of the patent in which they appear. 37 C.F.R. § 42.100(b); *see In re Cuozzo Speed Techs., LLC*, 793 F.3d 1268, 1275–79 (Fed. Cir. 2015). Claim terms generally are given their ordinary and customary meaning as would be understood by one of ordinary skill in the art in the context of the entire disclosure. *In re Translogic Tech., Inc.*, 504 F.3d 1249, 1257 (Fed. Cir. 2007). Significantly, claims are not interpreted in a vacuum but are part of, and read in light of, the specification. *United States v. Adams*, 383 U.S. 39, 49 (1966) (“[I]t is fundamental that claims are to be construed in the light of the specifications and both are to be read with a view to ascertaining the invention.”) (citations omitted).

An inventor may provide a special definition of the term in the specification, as long as this is done so “with reasonable clarity, deliberateness, and precision.” *In re Paulsen*, 30 F.3d 1475, 1480 (Fed. Cir. 1994). In the absence of such a definition, however, limitations are not to be read from the specification into the claims. *In re Van Geuns*, 988 F.2d 1181, 1184 (Fed. Cir. 1993).

### Claim Terms

“*weakly-ionized plasma*” and “*strongly-ionized plasma*”

Each of the independent claims from which the challenged claims depend recites “creat[ing] a *weakly-ionized plasma* and then a

*strongly-ionized plasma* from the weakly-ionized plasma.” Ex. 1201, 22:18–20, 23:14–16, 24:17–19. In our Institution Decision, we adopted Patent Owner’s proposed constructions, in light of the Specification, as the broadest reasonable interpretation of each of these claim terms. Inst. Dec. 9–11; *see, e.g.*, Ex. 1201, 9:24–25 (“the weakly-ionized plasma 232 has a low-level of ionization”), 12:11–12 (“The strongly-ionized plasma 268 is also referred to as a high-density plasma.”). Neither party has challenged our claim constructions as to these terms. PO Resp. 16–17; Ex. 2015 ¶ 20; Reply 2; Ex. 1228 ¶¶ 26–28. Upon consideration of the complete record now before us, we discern no reason to change our claim constructions set forth in the Institution Decision with respect to these claim terms. *See* Inst. Dec. 9–11. Therefore, we construe, in light of the Specification, the claim term “a weakly-ionized plasma” as “a plasma with a relatively low peak density of ions,” and the claim term “a strongly-ionized plasma” as “a plasma with a relatively high peak density of ions.”

*“without an occurrence of arcing”*

Each of the independent claims from which the challenged claims depend recites “creat[ing] a weakly-ionized plasma and then a strongly-ionized plasma from the weakly-ionized plasma *without an occurrence of arcing* between the anode and the cathode assembly.” Ex. 1201, 22:18–22, 23:14–18, 24:17–20. We did not provide an express construction of the claim term “without an occurrence of arcing” in our Institution Decision. The Specification of the ’421 patent does not recite or explicitly define the claim term. Rather, it discloses a process that *reduces or substantially*

*eliminates the possibility of* the occurrence of arcing when high-power pulses are applied to a pre-ionized plasma.

For instance, the Specification of the '421 patent discloses:

Forming a weakly-ionized or pre-ionized plasma *substantially eliminates the probability* of establishing a breakdown condition in the chamber 202 when high-power pulses are applied between the cathode assembly 216 and the anode 238. . . . The *probability of establishing a breakdown condition is substantially eliminated* because the weakly-ionized plasma has a low-level of ionization that provides electrical conductivity through the plasma. This conductivity *greatly reduces or prevents the possibility of a breakdown condition* when high power is applied to the plasma.

*Id.* at 9:16–28 (emphases added).

As described herein, the formation of weakly-ionized plasma 262 *substantially eliminates the possibility of creating a breakdown condition* when high-power pulses are applied to the weakly-ionized plasma 262. The suppression of this breakdown condition *substantially eliminates the occurrence of undesirable arcing* between the anode 238 and the cathode assembly 216.

*Id.* at 15:66–16:5 (emphases added).

In its Response, Patent Owner argues both that the claims require creation of the weakly-ionized plasma without an occurrence of arcing (*see, e.g.,* PO Resp. 11, 14, 16, 18, 28; Tr. 59:22–62:7), and that “[w]hile the presence of pre-ionized plasma in figure 6 [of Wang] reduces the likelihood of arcing, Wang never says that the background power  $P_B$  entirely eliminated arcing after ignition” (PO Resp. 33, citations omitted).



We first address Patent Owner's argument that the claims require no arcing during creation of the weakly-ionized plasma. Here, Patent Owner improperly attempts to import extraneous limitations into the claim by arguing repeatedly that the claims require that arcing is avoided, *even on plasma ignition*. See, e.g., PO Resp. 11, 14, 16, 18, 28; Tr. 59:22–62:7. Patent Owner's interpretation, however, is not consistent with the language of the claims, particularly when considered in view of the Specification. The plain claim language of the independent claims, which recite "creat[ing] a weakly-ionized plasma and then a strongly-ionized plasma without an occurrence of arcing," supports a claim construction where the claim phrase "without an occurrence of arcing" modifies only the portion of the claim reciting the transition to a strongly-ionized plasma from a weakly-ionized plasma. Further, as seen in the quoted portions of the Specification set forth above, the Specification of the '421 patent describes the weakly-ionized plasma as substantially eliminating the setup of a breakdown condition, and thus arcing, *when the high-power pulses are applied across the weakly-ionized plasma* to generate a strongly-ionized plasma from the weakly-ionized plasma; the Specification does not support Patent Owner's assertion that the setup of a breakdown condition, or arcing, also be substantially eliminated *when the weakly-ionized plasma itself is formed*. In fact, the Specification indicates that it is the presence of the weakly-ionized plasma that provides for the ability to substantially eliminate arcing when the high-power pulses are applied. See Ex. 1201, 9:16–28, 15:66–16:5. Accordingly, we decline to construe the claims to require creation of the

weakly-ionized plasma without an occurrence of arcing. *See In re NTP, Inc.*, 654 F.3d 1279, 1288 (Fed. Cir. 2011) (stating that the Board’s claim construction “cannot be divorced from the specification and the record evidence”); *see also In re Cortright*, 165 F.3d 1353, 1358 (Fed. Cir. 1999) (stating that the Board’s claim construction “must be consistent with the one that those skilled in the art would reach”).

We now address Patent Owner’s focus on the distinction between reducing versus eliminating. *See* PO Resp. 33. Patent Owner does not explain adequately why *one with ordinary skill in the plasma art* would have interpreted the claim term “without developing an electrical breakdown condition,” *in light of the Specification*, to require the transformation of the weakly-ionized plasma to a strongly-ionized plasma with a guarantee of eliminating *all possibility* of arcing. *See In re NTP, Inc.*, 654 F.3d at 1288; *In re Cortright*, 165 F.3d at 1358. One with ordinary skill in the art would have recognized that electrical arcing in a real-world plasma sputtering apparatus occurs naturally under certain processing conditions. In this regard, Dr. Overzet testifies that “[a] person of skill in the art would recognize that arcing is undesirable and it is always the goal to completely prevent arcing from occurring. However, *it is not possible to construct a perfect system and there is always a possibility that a system will arc.*” Ex. 1228 ¶ 51 (emphases added). We credit the testimony of Dr. Overzet as it is consistent with the Specification of the ’421 patent, which discloses only that the possibility of arcing is “substantially eliminated” or “greatly reduced.” Ex. 1201, 9:16–28, 15:66–16:5.

It is well settled that “[a] claim construction that excludes the preferred embodiment is rarely, if ever, correct and would require highly persuasive evidentiary support.” *Adams Respiratory Therapeutics, Inc. v. Perrigo Co.*, 616 F.3d 1283, 1290 (Fed. Cir. 2010) (internal quotations omitted). A construction that excludes all disclosed embodiments, as urged by Patent Owner here, is especially disfavored. *MBO Labs., Inc. v. Becton, Dickinson & Co.*, 474 F.3d 1323, 1333 (Fed. Cir. 2007). In short, claim construction requires claim terms to be read so that they encompass the very preferred embodiment they describe. *On-Line Techs., Inc. v. Bodenseewerk Perkin-Elmer GmbH*, 386 F.3d 1133, 1138 (Fed. Cir. 2004).

Here, nothing in the Specification indicates that the possibility of arcing is *completely eliminated* when the weakly-ionized plasma is transformed to a strongly-ionized plasma. Rather, it explicitly states that “the formation of weakly-ionized plasma 262 *substantially eliminates* the possibility of creating a breakdown condition when high-power pulses are applied to the weakly-ionized plasma 262,” and “[t]he suppression of this breakdown condition *substantially eliminates* the occurrence of undesirable arcing between the anode 238 and the cathode assembly 216.” Ex. 1201, 15:66–16:5 (emphases added).

Given the disclosure in the Specification, we decline to construe the claims to require the transformation of the weakly-ionized plasma to a strongly-ionized plasma occur with a *guarantee* of eliminating *all possibility* of an electrical breakdown condition or arcing, because it would be unreasonable to exclude the disclosed embodiments, all of which stop short

of such a guarantee. *See Phillips v. AWH Corp.*, 415 F.3d 1303, 1315 (Fed. Cir. 2005) (en banc) (stating that the Specification is “the single best guide to the meaning of a disputed term”). Instead, we construe the claim term “without developing an electrical breakdown condition in the chamber” as “substantially eliminating the possibility of developing an electrical breakdown condition in the chamber,” consistent with an interpretation that one of ordinary skill in the art would reach when reading the claim term in the context of the Specification. Additionally, as noted above, we also decline to construe the claims to require formation of the weakly-ionized plasma without an occurrence of arcing, and instead, consistent with the Specification of the ’421 patent, determine the “without an occurrence of arcing” language modifies only the creation of the strongly-ionized plasma from the weakly-ionized plasma.

*“creates a weakly-ionized plasma and then a strongly-ionized plasma from the weakly-ionized plasma”*

Each of independent claims 1 and 17 recites “a voltage pulse . . . that *creates* a weakly-ionized plasma and then a strongly-ionized plasma from the weakly-ionized plasma.”<sup>7</sup> Ex. 1201, 22:18–20, 23:14–16. We did not provide an express construction of the term “creates” in our Institution Decision.

---

<sup>7</sup> Claim 34 recites, similarly, a “voltage pulse *creating* a weakly-ionized plasma and then a strongly-ionized plasma from the weakly-ionized plasma.” Ex. 1201, 24:17–19.

In its Response, Patent Owner proposes the phrase “creates a weakly-ionized plasma” should be interpreted as “ignites a gas from a state in which there is no plasma to a state in which a plasma exists, wherein the plasma is initially a weakly-ionized plasma . . . .” PO Resp. 22. In support of its proposed construction, Patent Owner identifies the following portions of the Specification in support of its construction (PO Resp. 18):

In operation, the pulsed power supply 102 applies a voltage pulse between the cathode assembly 114 and the anode 130 that has a sufficient amplitude to ionize the argon feed gas in the vacuum chamber 104.

Ex. 1201, 4:13–15.

The amplitude and shape of the voltage pulse are such that a weakly-ionized plasma is generated in the region 246 between the anode 238 and the cathode assembly 216.

*Id.* at 8:19–21.

In one embodiment, the pulsed power supply 234 generates a low power pulse . . . in order to generate the weakly-ionized plasma.

*Id.* at 8:29–34.

Patent Owner also cites to Dr. Kortshagen’s deposition, in which he testified the mechanism of the “creation of a plasma” is “typically referred to as ignition of the plasma where you go from a state where you do not have a plasma present to a state where you now have a plasma present.” PO Resp. 19; Ex. 2017, 12:13–24. Patent Owner further contends that Petitioner’s discussion of Wang in the Petition suggests Petitioner uses “creates a weakly-ionized plasma” to refer to “ignition of a gas to cause a plasma to come into existence.” PO Resp. 19–20.

Petitioner argues that Patent Owner's proposed construction improperly reads an "ignite" limitation into the claims. Reply 2. Petitioner argues the Specification of the '421 patent describes other embodiments that support a broader interpretation of "creates," and proposes the term should be construed to have its plain and ordinary meaning or an explicit construction of "forms or generates." *Id.* at 3–4 (citing Ex. 1201, 16:42–44, 16:48–51).

Initially, we note Patent Owner has not identified, nor do we find, any portion of the Specification of the '421 patent that explicitly defines the term "creates." The '421 patent describes choosing characteristics of a voltage pulse such that an electric field develops that creates a weakly-ionized plasma. Ex. 1201, 11:14–20. However, the '421 patent also uses the term "creates" in various other contexts. For example, the '421 patent describes strongly-ionized plasma tends to diffuse homogeneously in region 264, which "creates a more homogeneous plasma volume," and the high power pulse "creates strongly-ionized plasma." *Id.* at 12:16–19, 20:22–24. The '421 patent further describes an initial voltage that "creates a plasma discharge voltage." *Id.* at 8:53–56.

We are not persuaded by Patent Owner's contention that one of ordinary skill in the art would interpret "creates a weakly-ionized plasma" as suggested (PO Resp. 18–22). In its Motion on Observations, Patent Owner further argues that Dr. Overzet's deposition testimony supports its proposed construction. Paper 44, 1–5. We are not persuaded, however, that Dr. Overzet's cited testimony supports Patent Owner's proposal, nor is it

necessary for construction of the claims; instead, we determine the meaning of the claim limitation is apparent from the intrinsic evidence alone.

Based on the evidence before us, we determine that “creates” would be understood by one of ordinary skill in the art to mean “to bring into existence,” consistent with the use of the word in the Specification and the plain and ordinary meaning thereof. *See Create Definition*, Merriam-Webster’s Collegiate Dictionary 271 (10th edition 2000). Furthermore, the ’421 patent does not explicitly define “creates a weakly-ionized plasma.” While Patent Owner provides examples described in the Specification (PO Resp. 18), we will not import the suggested “ignition” limitation into the claim. *See Renishaw PLC v. Marposs Societa’ per Azioni*, 158 F.3d 1243, 1248 (Fed. Cir. 1998); *see also, SuperGuide Corp. v. DirectTV Enters., Inc.*, 358 F.3d 870, 875 (Fed. Cir. 2004) (“Though understanding the claim language may be aided by the explanations contained in the written description, it is important not to import into a claim limitations that are not a part of the claim.”).

As such, we interpret the term “creates a weakly-ionized plasma” as “brings into existence a weakly-ionized plasma,” and do not limit the claim to a circumstance that the gas is ignited from a state in which there is no existing plasma, as proposed by Patent Owner.

*“pulse”*

Each of independent claims 1 and 17 recites “a power supply that generates a voltage pulse.”<sup>8</sup> Ex. 1201, 22:17, 23:13. Patent Owner asserts the term “pulse” should be given its ordinary meaning, but does not proffer any “formal construction.” PO Resp. 17. Petitioner proposes we construe “pulse” as “a property (e.g., voltage, current, or power) that is applied over a period of time.” Reply 6.

The parties’ dispute with respect to this term focuses on the application of the cited art to the claims, rather than on a particular meaning of the term itself. For this reason, we do not provide an express construction for this term. Instead, we address the parties’ arguments regarding the usage of the term “pulse” in more detail below, in the context of applying the cited art to the claims.

*B. Principles of Law*

To prevail in its challenges to the patentability of the claims, Petitioner must prove unpatentability by a preponderance of the evidence. 35 U.S.C. § 316(e); 37 C.F.R. § 42.1(d). A claim is unpatentable under 35 U.S.C. § 103 if the differences between the claimed subject matter and the prior art are such that the subject matter, as a whole, would have been obvious at the time the invention was made to a person having ordinary skill in the art to which said subject matter pertains. *KSR Int’l Co. v. Teleflex Inc.*, 550 U.S. 398, 406 (2007). The question of obviousness is resolved on

---

<sup>8</sup> Claim 34 recites, similarly, “generating a voltage pulse.” Ex. 1201, 24:15.



the basis of underlying factual determinations including: (1) the scope and content of the prior art; (2) any differences between the claimed subject matter and the prior art; (3) the level of ordinary skill in the art; and (4) objective evidence of nonobviousness. *Graham v. John Deere Co.*, 383 U.S. 1, 17–18 (1966).

In that regard, an obviousness analysis “need not seek out precise teachings directed to the specific subject matter of the challenged claim, for a court can take account of the inferences and creative steps that a person of ordinary skill in the art would employ.” *KSR*, 550 U.S. at 418; *see Translogic*, 504 F.3d at 1259. A prima facie case of obviousness is established when the prior art itself would appear to have suggested the claimed subject matter to a person of ordinary skill in the art. *In re Rinehart*, 531 F.2d 1048, 1051 (CCPA 1976). The level of ordinary skill in the art is reflected by the prior art of record. *See Okajima v. Bourdeau*, 261 F.3d 1350, 1355 (Fed. Cir. 2001); *In re GPAC Inc.*, 57 F.3d 1573, 1579 (Fed. Cir. 1995); *In re Oelrich*, 579 F.2d 86, 91 (CCPA 1978).

We analyze the asserted grounds of unpatentability in accordance with the above-stated principles.

*C. Obviousness Over Wang in Combination with Kudryavtsev*

Petitioner asserts that each of claims 9, 21, and 35 is unpatentable under 35 U.S.C. § 103 as obvious over the combination of Wang and Kudryavtsev. Pet. 43–56. Petitioner explains how each claim limitation is disclosed in or taught by the cited references, and provides an articulated reasoning with rational underpinning to support combining the prior art

teachings. *Id.* Petitioner also relies on the Declarations of Dr. Kortshagen (Ex. 1202) and Dr. Overzet (Ex. 1228) to support its Petition and Reply, respectively. Patent Owner responds that Wang does not disclose every element of the independent claims from which claims 9, 21, and 35 depend, relying on the Declaration of Dr. Hartsough (Ex. 2015) to support its Response. PO Resp. 23–44.

We have reviewed the entire record before us, including the parties' explanations and supporting evidence presented during this trial. We begin our discussion with a brief summary of Wang, and then we address the parties' contentions in turn.

#### Wang

Wang discloses a power pulsed magnetron sputtering method for generating a very high plasma density. Ex. 1204, Abstract. Wang also discloses a sputtering method for depositing metal layers onto advanced semiconductor integrated circuit structures. *Id.* at 1:4–15.

Figure 1 of Wang, reproduced below, illustrates a cross-sectional view of a magnetron sputtering reactor:

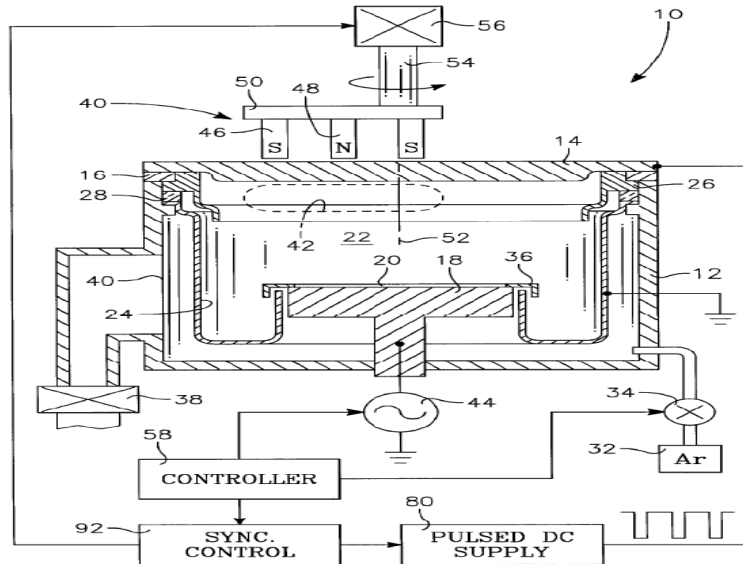

FIG. 1

As shown in Figure 1 of Wang, magnetron sputtering apparatus 10 has pedestal 18 for supporting semiconductor substrate 20, anode 24, cathode 14, magnet assembly 40, and pulsed DC power supply 80. Ex. 1204, 3:57–4:55. According to Wang, the apparatus creates high-density plasma in region 42, which ionizes a substantial fraction of the sputtered particles into positively charged metal ions and also increases the sputtering rate. *Id.* at 4:13–34. Magnet assembly 40 creates a magnetic field near target 14, which traps electrons from the plasma to increase the electron density. *Id.* at 4:23–27. Wang further recognizes that, if a large portion of the sputtered particles are ionized, the films are deposited more uniformly and effectively. *Id.* at 1:24–29.

Figure 6 of Wang, reproduced below, illustrates how the apparatus applies a pulsed power to the plasma:

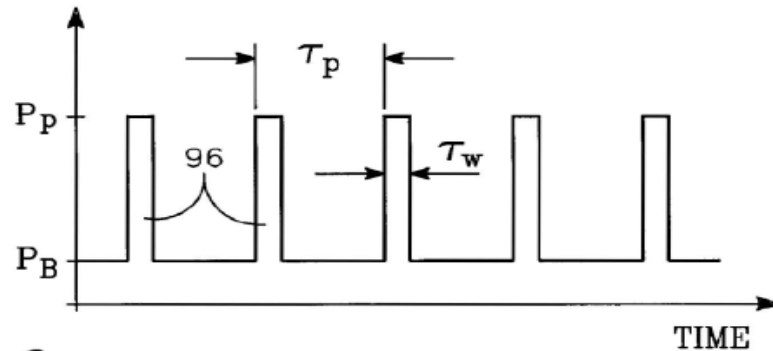

FIG. 6

As shown in Figure 6 of Wang, the target is maintained at background power level  $P_B$  between high power pulses 96 with peak power level  $P_P$ . Ex. 1204, 7:13–39. Background power level  $P_B$  exceeds the minimum power necessary to support a plasma in the chamber at the operational pressure (e.g., 1 kW). *Id.* Peak power  $P_P$  is at least 10 times (preferably 100 or 1000 times) background power level  $P_B$ . *Id.* The application of high peak power  $P_P$  causes the existing plasma to spread quickly, and increases the density of the plasma. *Id.* According to Dr. Kortshagen, Wang's apparatus generates a low-density (weakly-ionized) plasma during the application of background power  $P_B$ , and a high-density plasma during the application of peak power  $P_P$ . Ex. 1202 ¶ 126; *see* Pet. 45–46. In Wang, background power  $P_B$  may be generated by DC power supply 100 and peak power  $P_P$  may be generated by pulsed power supply 80. Ex. 1204, 7:56–64, Fig. 7; Ex. 1202 ¶ 42.

Independent Claims 1, 17, and 34

Petitioner explains how each limitation of independent claims 1, 17, and 34 is disclosed in Wang. Pet. 43–52. For example, regarding claim 1, Petitioner contends that anode 24 and the cathode assembly, including sputtering target 14, of Wang disclose the claimed cathode assembly adjacent an anode. *Id.* at 43–44; Ex. 1204, 3:33–4:1; Ex. 1202 ¶ 122. Petitioner further contends that the combination of DC power supply 100 and pulsed DC power supply 80, the outputs of each of being coupled to cathode target 14, discloses the claimed power supply that generates a voltage pulse. Pet. 44–45; Ex. 1204, 3:66–4:1, 7:58–62, Figs. 1, 6, 7; Ex. 1202 ¶¶ 123–125. According to Petitioner, DC power supply 100 of Wang supplies background power  $P_B$  that generates a low density plasma, thus disclosing creating a weakly-ionized plasma, and pulsed DC power supply 80 of Wang supplies peak power  $P_P$  that generates a high density plasma from the weakly-ionized plasma, thus disclosing creating a strongly-ionized plasma. Pet. 45–46; Ex. 1204, 7:17–39; Ex. 1202 ¶¶ 126–127. Petitioner contends that Wang also discloses forming the strongly-ionized plasma without arcing. Pet. 46–47; Ex. 1204, 7:3–6, 7:13–28, 7:47–49, Fig. 6; Ex. 1202 ¶¶ 128–129. Petitioner further contends that Wang discloses the voltage pulse having an amplitude, duration, and/or rise time to result in an increased density of ions in the strongly-ionized plasma. Pet. 47–49; Ex. 1204, 5:23–26, 7:19–30; Ex. 1202 ¶¶ 130–131. In its discussion of claims 17 and 34, Petitioner primarily refers back to its discussion of corresponding limitations of claim 1. *See* Pet. 49–52.

Regarding claim 17, Petitioner further relies on pedestal electrode 18 and RF power source 44 of Wang as disclosing the claimed substrate support and bias voltage source. Pet. 49–50; Ex. 1204, 3:63–66, 4:32–34; Ex. 1202 ¶¶ 136–137.

With respect to the independent claims, the parties’ dispute mainly centers on: (1) whether Wang discloses the claimed “*power supply that generates a voltage pulse between the anode and the cathode assembly that creates a weakly-ionized plasma and then a strongly-ionized plasma from the weakly-ionized plasma without an occurrence of arcing*”; and (2) whether Wang discloses “an amplitude, a duration [and/or] a rise time of the voltage pulse being *chosen* to increase a density of ions in the strongly-ionized plasma,” as claimed. We address each of these limitations in turn.

“power supply that generates a voltage pulse between the anode and the cathode assembly that creates a weakly-ionized plasma and then a strongly-ionized plasma from the weakly-ionized plasma”

According to Petitioner, “[power] supply 100 [of Wang] generates the voltage used for the background power,  $P_B$ , and pulsed [power] supply 80 generates the train of voltage pulses used to produce the peak power,  $P_P$ .” Pet. 44 (citing Ex. 1204, 7:58–61). Petitioner continues that the “outputs of pulsed DC power supply 80 and DC power supply 100 are coupled to the cathode 14,” and the “[c]ombined pulsed DC power supply 80 and DC power supply 100 generate the pulsed waveform illustrated in Figs. 6 and 7.” *Id.* at 44–45 (citing Ex. 1204, Figs. 1, 7; Ex. 1202 ¶ 124). The background power  $P_B$  of Wang generates a low-density (i.e., a weakly-ionized plasma)

and the peak power  $P_P$  generates a high-density plasma (i.e., a strongly-ionized plasma). *Id.* at 45–46 (citing Ex. 1204, 7:17–31; Ex. 1202 ¶ 126).

In its Response, Patent Owner argues that Wang does not disclose a *single* power supply that generates a voltage *pulse* that *creates* a weakly-ionized plasma. We address each emphasized feature in turn.

Regarding Patent Owner’s arguments that Wang does not disclose “creating” a weakly-ionized plasma, we note these arguments are based on an incorrect construction of “create”—one that improperly imports an “ignition” requirement into the claim—as discussed above. *See supra* Section II.A. We are persuaded that Petitioner has shown sufficiently that Wang discloses bringing a weakly-ionized plasma into existence, which meets the claim language based on the broadest reasonable interpretation thereof. *See, e.g.*, Ex. 1204, 7:17–19 (“The background [power] level  $P_B$  is chosen to exceed the minimum power necessary to support a plasma in the chamber at the operational pressure.”); *id.* at Fig. 6.

Regarding Patent Owner’s assertion that the voltage pulse must be generated by a single power supply (PO Resp. 7–13, 26–27, 32–38), we are not persuaded that the claims are so limited. We agree with Petitioner that nothing in the claim language precludes a DC power supply from contributing to the claimed pulse. *See* Reply 14. Dr. Overzet testifies that the “collection of components shown in Fig. 7 of Wang [e.g., those circled in red in the annotated figure provided below,] fall within the broadest reasonable interpretation of a ‘power supply’ because they work together to

provide power to a target.” Reply 10 n.2 (citing Ex. 1228 ¶ 58). The annotated version of Figure 7 of Wang to which Dr. Overzet refers is reproduced below (Ex. 1228 ¶ 57):

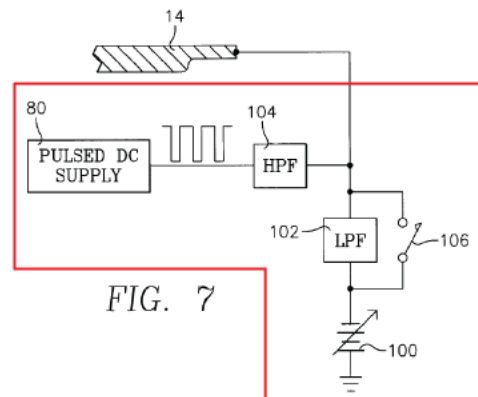

The annotated version of Figure 7, reproduced above, illustrates a combined power supply of Wang. As noted by Dr. Overzet, “properties such as power are additive, which means that they can be combined to produce a desired result.” Ex. 1228 ¶ 57. In this instance, the components circled in red above, cooperate to produce the waveform shown in Figure 6 of Wang, thus disclosing the required power supply. *Id.*; *see* Pet. 44–45. We agree.

We also do not find Patent Owner’s arguments that the background power  $P_B$  of Wang does not disclose a “voltage pulse,” as claimed, to be persuasive. As discussed above, Petitioner relies on the combination of background power  $P_B$  and peak power  $P_P$  as disclosing a waveform corresponding to the claimed “voltage pulse.” *See* Pet. 44–45.

Patent Owner attempts to distinguish between a “continuous” power supply versus a “pulsed” power supply. *See, e.g.*, PO Resp. 9–15. However, even Patent Owner’s arguments regarding the claimed “voltage pulse”



obfuscate any distinction in this regard. For example, Patent Owner asserts that “[t]he [low power] pulse, by definition has a limited duration called the ‘pulse width.’ But *before the pulse terminates* (i.e., while the weakly ionized plasma is present), the same pulsed power supply 234 increases its power output to transition the weakly ionized plasma to a strongly-ionized plasma.” PO Resp. 12 (emphasis added) (citing Ex. 1201, 8:34–36, 9:29–32, 11:21–26, 11:60–62, Figs. 5A–5D, and related discussion; Ex. 2015 ¶¶ 64–70). It is unclear how a pulse can both have a distinct pulse width, that according to Patent Owner must be present in order to be considered a “pulse,”<sup>9</sup> and still remain present when the power is increased to transition the weakly-ionized plasma to a strongly-ionized plasma.

Notably, the waveform disclosed in Wang is the same waveform as that of the disclosed embodiments of the ’421 patent. An annotated comparison of Figure 6 of the ’421 patent and Figure 6 of Wang, provided by Dr. Overzet (Ex. 1228 ¶ 38), is reproduced below.

---

<sup>9</sup> See, e.g., PO Resp. 27 (arguing that Wang does not disclose “termination of the DC power supply’s output or a ‘pulse width’ of that output” and that, thus, the “output emitted by the DC supply [of Wang] is not a pulse having a chosen duration, but is instead a continuous power as shown by the baseline in figure 6”).

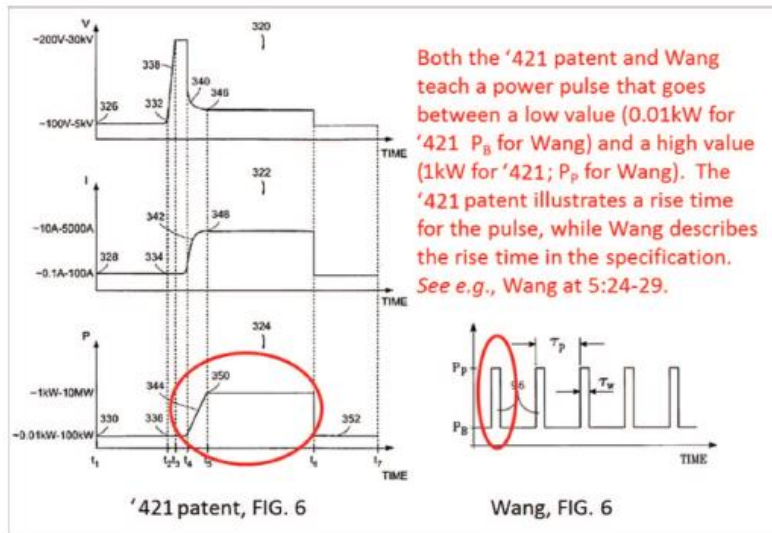

As can be seen in the annotated comparison shown above, Figure 6 of Wang illustrates that same approach as described in the '421 patent. Ex. 1228 ¶¶ 53–55; Ex. 1201, 15:56–58, 16:32–53, Fig. 6. More specifically, the “periodic pulses applied to the plasma” shown in Figure 6 of the '421 patent, are described as being supplied by the pulsed power supply 234, where the “pulsed power supply 234 continues to supply a background power that is sufficient to maintain the plasma after time  $t_6$  . . . , while the pulsed power supply 234 prepares to deliver the next high-power pulse.” Ex. 1201, 15:37–16:51. We, thus, are persuaded that the periodic pulse waveform described in Wang is sufficient to disclose the claimed “voltage pulse . . . that creates a weakly-ionized plasma and then a strongly-ionized plasma from the weakly-ionized plasma.”

Given the evidence before us in the entire record, for the reasons discussed above, we determine that Petitioner has demonstrated, by a preponderance of evidence, that Wang discloses a “power supply that

generates a voltage pulse between the anode and the cathode assembly that creates a weakly-ionized plasma and then a strongly-ionized plasma from the weakly-ionized plasma.”

“creates a weakly-ionized plasma and then a strongly-ionized plasma from the weakly-ionized plasma without an occurrence of arcing between the anode and the cathode assembly”

Petitioner asserts that Wang discloses “forming the strongly-ionized plasma . . . without arcing,” as required by the claims. Pet. 46–47. Figure 6 of Wang is reproduced below (annotations by Petitioner, Pet. 12):

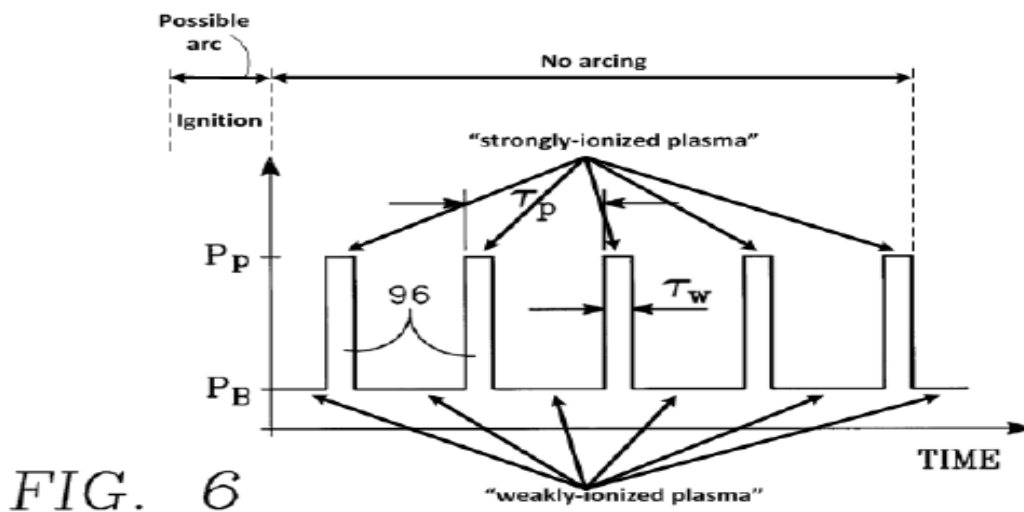

As shown in annotated Figure 6, the target is maintained at background power level  $P_B$  between power pulses 96, rising to peak power level  $P_P$ . Ex. 1204, 7:13–25. Background level  $P_B$  is chosen to exceed the minimum power necessary to support a plasma with little, if any, actual sputter deposition. *Id.* The initial plasma ignition needs to be performed only once, and at a very low power level so that particulates produced by arcing are much reduced. *Id.* at 7:26–55. According to Dr. Kortshagen, because “the

plasma need not be reignited thereafter, arcing will not occur during subsequent applications of the background and peak power levels,  $P_B$  and  $P_P$ .” Pet. 47; Ex. 1202 ¶ 129; *see also* Ex. 1204, 7:25–28 (“As a result, once the plasma has been ignited at the beginning of sputtering prior to the illustrated waveform [Fig. 6], no more plasma ignition occurs.”).

In its Response, Patent Owner argues that Wang does not disclose eliminating arcing. PO Resp. 33–34. In this regard, Patent Owner draws a distinction between *reducing* electrical breakdown conditions and *eliminating* electrical breakdown conditions. *Id.* For example, Patent Owner argues that “[w]hile the presence of a pre-ionized plasma in figure 6 [of Wang] reduces the likelihood of arcing, Wang never says that the background power  $P_B$  entirely eliminated arcing after ignition.” *Id.* at 33 (citing Ex. 1204, 7:47–49; Ex. 2014, 155:24–156:5).

Based on the evidence before us, we are not persuaded by Patent Owner’s arguments. As noted in our claim construction above, we do not construe the claims to require a guarantee of eliminating *all possibility* of an electrical breakdown condition or arcing. Wang discloses that the on-and-off pulsing in the first embodiment (shown in Figure 4), where arcing admittedly occurs, can be improved further by maintaining a background power level  $P_B$  between pulses to avoid arcing, as illustrated by Wang’s second embodiment in Figure 6. *See* Ex. 1204, 7:1–8:14. Notably, Wang recognizes that, in the first embodiment (shown in Figure 4), because the plasma is ignited with a high power pulse in each pulse cycle, the chamber impedance dramatically changes between the on-and-off phases,

and large particles are dislodged from the target or chamber. *Id.* at 5:28–32, 7:1–13. By contrast, in Wang’s second embodiment (as shown in Figure 6), the plasma is ignited only once at a much lower power level  $P_B$ , the “chamber impedance changes relatively little between the two power levels  $P_B, P_P$ ,” (e.g., during the pulse). *Id.* at 7:47–55.

Further still, the power supply operation parameters disclosed in Wang, fall within the broad ranges disclosed in the ’421 patent. *See* Ex. 1228 ¶¶ 38–40; *compare* Ex. 1201, 15:37–17:17, Fig. 6, *with* Ex. 1204, 7:13–25, 5:66–67, Fig. 6. We, thus, are persuaded that one of ordinary skill in the art would have recognized the embodiment illustrated in Figure 6 of Wang discloses “forming the strongly-ionized plasma . . . without arcing,” as required by the claims.

Given the evidence before us in the entire record, we determine that Petitioner has demonstrated, by a preponderance of evidence, that Wang discloses “creat[ing] . . . a strongly-ionized plasma from the weakly-ionized plasma without an occurrence of arcing between the anode and the cathode assembly,” as claimed.

“an amplitude, a duration and a rise time of the voltage pulse being chosen to increase a density of ions in the strongly-ionized plasma”

Independent claims 1 and 17 each recite “an amplitude, a duration and a rise time of the voltage pulse being chosen to increase a density of ions in the strongly-ionized plasma.” Ex. 1201, 22:22–24, 23:18–20. Independent claim 34 includes a similar limitation. As previously discussed, Petitioner asserts that “Wang generates . . . a high density plasma with the peak power

$P_p$ .” Pet. 45; *see also* Ex. 1204, 7:29–31 (“[T]he application of the high peak power  $P_p$  . . . quickly causes the already existing [weakly-ionized] plasma to spread and increases the density of the plasma.”).

According to Petitioner, “Wang’s voltage pulse changes the power level from the background power,  $P_B$ , to the peak power,  $P_p$ , . . . and each of those peak pulses increases the density of the plasma such that a strongly-ionized plasma is formed. Moreover, the density of Wang’s strongly-ionized plasma increases during application of the peak power,  $P_p$ .”

Pet. 47–48 (citing Ex. 1204, 7:28–30; Ex. 1202 ¶ 130). Petitioner continues, “Wang therefore generates a ‘voltage pulse’ that increases the ‘density of ions.’ Wang’s voltage pulse has an amplitude, a duration, and a rise time.” *Id.* at 48 (citing Ex. 1202 ¶ 131). Petitioner asserts that “[o]ne of ordinary skill would have understood that Wang’s voltage amplitude and duration was controlled to produce Wang’s specified peak power level  $P_p$ .” *Id.* (citing Ex. 1202 ¶ 131).

Patent Owner asserts that Petitioner’s arguments are conclusory and not supported by Wang. PO Resp. 38. Patent Owner supports this assertion, stating merely because an applied electrical pulse has an associated rise time, duration, and amplitude, as in Wang, does not necessitate that the rise time, duration, or amplitude was somehow *chosen* to achieve the result of the claims. *Id.* at 39–41. Patent Owner’s arguments are not persuasive.

Wang selects pulse characteristics and reactors with the goal of “producing a high fraction of ionized sputtered particles” and increasing the density of the plasma, which “has long been exploited in high-density

plasma.” *See* Ex. 1204, 1:7–8, 1:30–37, 7:13–30. We are persuaded that one of ordinary skill in the art would have understood from Wang’s disclosure that the parameters of the rise time, duration, and amplitude of a pulse must be controlled, to achieve the desired result, in this instance, to increase the density of the plasma. *See, e.g.*, Ex. 1202 ¶ 131; Ex. 1228 ¶¶ 59–60.

In addition, claims 1 and 17 are apparatus claims and claim 34 is a method claim. With respect to the apparatus claims, we are persuaded that the claim recites an intended use that will not limit the scope of the claim, such that anticipation of the claims is based on whether the elements of that claim are disclosed, not on their intended use. With respect to claim 34, the method does not require an optimization of magnitude or rise time to achieve the strongly-ionized plasma, but simply that the amplitude and the rise time of the voltage pulse achieve an increased density of ions, which Wang discloses, as discussed above.

Based on the evidence before us, we are persuaded that Petitioner has demonstrated, by a preponderance of evidence, that Wang discloses choosing an amplitude, a duration, and a rise time of the voltage pulse, in order to increase a density of ions in the strongly-ionized plasma.

For the reasons discussed, we determine that Petitioner has demonstrated, by a preponderance of evidence, that Wang discloses all limitations of claims 1, 17 and 34.

Dependent Claims 9, 21, and 35

Claims 9 and 21 depend from claims 1 and 17, respectively, and recite “wherein the voltage pulse generated between the anode and the cathode assembly excites atoms in the weakly-ionized plasma and generates secondary electrons from the cathode assembly, the secondary electrons ionizing a portion of the excited atoms, thereby creating the strongly-ionized plasma.” Ex. 1201, 22:52–57, 23:37–42. Claim 35 depends from claim 34 and includes similar limitations. *Id.* at 24:25–30. Patent Owner does not provide separate arguments or otherwise address these claims in its Response, beyond the arguments provided with respect to the independent claims, which we do not find persuasive for the reasons discussed above.

Petitioner relies on Kudryavtsev for teaching that “ionization proceeds in a slow stage followed by a fast stage and that excited atoms are produced in both stages.” Pet. 53 (referring back to Pet. 26–30; citing Ex. 1202 ¶ 147). Petitioner continues, “[e]xcited atoms will therefore be produced in Wang’s weakly-ionized plasma in response to the voltage pulse.” *Id.* (citing Ex. 1202 ¶ 147). Petitioner further asserts that the background section of the ’421 patent “admits . . . that secondary electrons are produced by collisions [of ions] with the cathode” (Pet. 55 (referring back to Pet. 31; citing Ex. 1202 ¶ 152)), and that “Kudryavtsev [also] teaches that collisions between secondary electrons and excited atoms produce ions” (Pet. 55 (referring back to Pet. 32–33; citing Ex. 1202 ¶ 153)). Therefore, according to Petitioner, the combination of Wang and Kudryavtsev teaches the



additional limitations of claims 9, 21, and 35. Pet. 55–56 (citing Ex. 1202 ¶ 153).

Petitioner further contends that, based on Kudryavtsev’s teaching that “the effects studied in [Kudryavtsev] are characteristic of ionization *whenever a field is suddenly applied to a weakly ionized gas*” (Ex. 1206, 34 (emphasis added)), one of ordinary skill in the art would have been motivated to consider Kudryavtsev, when reading Wang, “to better understand the effects of applying Wang’s pulse,” that “suddenly generate[s] an electric field.” Pet. 53–54 (citing Ex. 1202 ¶ 148).

We are persuaded by Petitioner’s contentions and evidence. Given the evidence in the record before us, we determine that Petitioner has demonstrated, by a preponderance of evidence, that each of claims 9, 21, and 35 would have been obvious in view of Wang and Kudryavtsev.

*D. Obviousness Over Wang and Mozgrin Thesis*

Petitioner asserts that each of claims 14, 26, and 37 is unpatentable under 35 U.S.C. § 103 as obvious over the combination of Wang and Mozgrin Thesis. Pet. 56–58. Petitioner explains how each limitation is disclosed in or taught by the cited references, as well as provides an articulated reasoning with rational underpinning to support combining the prior art teachings. *Id.* Petitioner again relies on the Declarations of Dr. Kortshagen (Ex. 1202) and Dr. Overzet (Ex. 1228) to support its Petition and Reply, respectively. Except to dispute the prior art status of the Mozgrin Thesis, which we discuss below, Patent Owner does not provide separate arguments or otherwise address these claims in its Response, beyond the

arguments provided with respect to the independent claims, which we do not find persuasive for the reasons discussed above.

Claims 14, 26, and 37 depend from claims 1, 17, and 34, respectively, and each recites a “rise time of the voltage pulse is in the range of approximately 0.01V/μsec to 1000V/μsec.” Ex. 1201, 23:1–3, 23:54–56, 24:34–36. Petitioner relies on Mozgrin Thesis as disclosing the claimed rise time. Pet. 56 (referring back to Pet. 34–35; citing Ex. 1207, 63 (Fig. 3.2); Ex. 1202 ¶¶ 95–98, 156). According to Petitioner, “[o]ne of ordinary skill would have been motivated to use the rise time and pulse of the Mozgrin Thesis in Wang so as to produce a dense plasma and provide desired sputtering[, and because b]oth Wang and Mozgrin Thesis address similar subject[s], such as pulsed sputtering, achieving high density plasma, and avoiding arcing.” *Id.* at 56–57 (citing Ex. 1202 ¶¶ 156–157; Ex. 1204, Abstract, 4:39–49; Ex. 1207, 4, 5, 25, 42, 102). Petitioner further contends that the “[u]se of Mozgrin Thesis’ rise time in Wang would have been a combination of old elements to yield predictable results.” *Id.* at 57 (citing Ex. 1202 ¶ 156). We are persuaded by Petitioner’s contentions and evidence and determine that Petitioner has shown, by a preponderance of the evidence, that the cited combination teaches the additional limitations of claims 14, 26, and 37.

Printed Publication under 35 U.S.C. § 102 — Mozgrin Thesis

We address the issue of whether the Mozgrin Thesis is available as prior art under 35 U.S.C. § 102(b)<sup>10</sup> for purposes of this Final Written Decision. The determination of whether a given reference qualifies as a prior art “printed publication” involves a case-by-case inquiry into the facts and circumstances surrounding the reference’s disclosure to members of the public. *In re Klopfenstein*, 380 F.3d 1345, 1350 (Fed. Cir. 2004). “Because there are many ways in which a reference may be disseminated to the interested public, ‘public accessibility’ has been called the touchstone in determining whether a reference constitutes a ‘printed publication’ bar under 35 U.S.C. § 102(b).” *In re Hall*, 781 F.2d 897, 898–99 (Fed. Cir. 1986). To qualify as a prior art printed publication, the reference must have been disseminated or otherwise made accessible to persons interested and ordinarily skilled in the subject matter to which the document relates prior to the critical date. *Kyocera Wireless Corp. v. Int’l Trade Comm’n*, 545 F.3d 1340, 1350 (Fed. Cir. 2008).

Petitioner asserts that the Mozgrin Thesis is a doctoral thesis at Moscow Engineering Physics Institute, published in 1994, and, thus, it is prior art under § 102(b). Pet. 4. To support its assertion, Petitioner proffers a copy of the catalog entry for the Mozgrin Thesis at the Russian State

---

<sup>10</sup> Paragraph (b) of 35 U.S.C. § 102 was replaced with newly designated § 102(a)(1) when § 3(b)(1) of AIA took effect on September 16, 2012. Because the application that issued as the ’421 patent was filed before that date, we refer to the pre-AIA version of § 102.

Library, and a certified English-language translation thereof. Ex. 1209. Petitioner also alleges that the catalog entry “also shows that it is the routine business practice of the [Russian State Library] to index and catalog theses.” Reply 20 (citing Ex. 1209). Dr. Kortshagen testifies that Mozgrin<sup>11</sup>—an article that was published in 1995—summarizes the research presented in the Mozgrin Thesis, and contains figures created from the photographs in the Mozgrin Thesis. Ex. 1202 ¶ 93.

In its Response, Patent Owner counters that Petitioner fails to demonstrate that the Mozgrin Thesis is prior art under § 102. PO Resp. 45–48. Patent Owner contends that Petitioner provides no evidence as to the actual date of cataloging of the Mozgrin Thesis. *Id.* Patent Owner further alleges that the Mozgrin Thesis was not sufficiently accessible to be considered a printed publication under § 102. *Id.* According to Patent Owner, the “document says nothing of when the [Moscow Engineering Physics] Institute (which is within the notoriously secretive former Soviet Union) decided to allow the public unrestricted access to this thesis.” *Id.* at 45–46.

Upon consideration of the facts in the present record, we are persuaded by Petitioner’s contentions and supporting evidence. Although evidence establishing a *specific* date of cataloging and shelving before the critical date would have been desirable, it is not required in a public

---

<sup>11</sup> D.V. Mozgrin et al., *High-Current Low-Pressure Quasi-Stationary Discharge in a Magnetic Field: Experimental Research*, 21 PLASMA PHYSICS REPORTS 400–409 (1995) (Ex. 1203).

accessibility determination. *See Hall*, 781 F.2d at 899. Here, the earliest possible critical date is *November 14, 2002*—the filing date of the earliest application to which the application that issued as the '421 patent claims priority. Ex. 1201, 1:5–11.

The certified English-language translation of the catalog entry is reproduced below with green annotations added (Ex. 1209, 1):

<b>Logotype of RSL</b>		<b>Catalog of Dissertations in Russian (since 1995)</b>	
<b>Full View of Record</b>			
<b>Global Holdings</b>	<a href="#">All items</a>		
<b>Holdings</b>	<a href="#">Department of dissertations (Khimki) 61 95-1/593-2</a>		
<b>Author</b>	<a href="#">Mozgrin Dmitry Vitalievich</a>		
<b>Title</b>	<a href="#">High-current low-pressure quasi-stationary discharge in a magnetic field: experimental research: ph.d. thesis in physics and mathematics: 01.04.08</a>		
<b>Imprint</b>	<a href="#">Moscow 1994</a>		
<b>Description</b>	<a href="#">122 pages, illustrations</a>		
<b>Language</b>	<a href="#">Russian</a>		
<b>Bibliography</b>	<a href="#">Bibliography: pages 111-122</a>		
<b>Subject – Other</b>	<a href="#">Plasma physics and chemistry</a>		
<b>Electronic Location</b>	<a href="http://dlib.rsl.ru/rsl01000000000/rsl01000165000/rsl01000165287/rsl01000165287.pdf">http://dlib.rsl.ru/rsl01000000000/rsl01000165000/rsl01000165287/rsl01000165287.pdf</a>		
<b>Parallel record</b>	<a href="#">Synopsis of a thesis</a>		

As depicted above, the catalog entry shows that it is an entry from the Russian State Library’s catalog of dissertations in Russian. Ex. 1209, 2. As we determined previously in the Institution Decision (Inst. Dec. 7–8), the catalog entry clearly shows a publication date of 1994 (“Imprint Moscow 1994”), well before the critical date of November 14, 2002. *Id.*

Patent Owner had the opportunity, during this trial, to object to evidence and file a motion to exclude the evidence submitted by Petitioner. Patent Owner, however, did not object under 37 C.F.R. § 42.64(b) to the

admissibility of the catalog entry or the Mozgrin Thesis. Notably, Patent Owner does not challenge the authenticity of these documents, nor allege that they constitute inadmissible hearsay. Therefore, the information set forth in the catalog entry can be relied upon by Petitioner as evidence supporting its contention that Mozgrin Thesis was cataloged in the Russian State Library, and that it was sufficiently accessible to the public before the critical date. Furthermore, Patent Owner does not provide sufficient explanation or credible evidence to rebut the information disclosed in the Russian State Library's catalog entry, including the 1994 publication date. For instance, Patent Owner does not explain why a library, such as the Russian State Library here, would take more than seven years to catalog and index a thesis.

The fact that the thesis was cataloged in Russia, a foreign country, does not change the result. Notably, the Federal Circuit has rejected the argument that a cataloged thesis shelved at a university library in Germany does not constitute sufficient accessibility to those interested in the art exercising reasonable diligence. *Hall*, 781 F.2d at 899– 900. The Federal Circuit also has held that an Australian patent application—classified and laid open to public inspection by the Australian Patent Office—was sufficiently accessible to interested persons to qualify as a prior art printed publication under § 102. *In re Wyer*, 655 F.2d 221, 225– 26 (Fed. Cir. 1981).

Patent Owner further asserts that the catalog entry includes a copyright notice of 2002 at the bottom of the page, and the number

“01.04.08” in the Title entry, also providing evidence that the document was not accessible prior to the critical date. PO Resp. 46. Neither of these arguments is persuasive. The 2002 date appears to be a claim of copyright in the Ex Libris database from which the catalog entry was retrieved, but does not indicate necessarily that this is the date at which the Ex Libris software first became available, as Patent Owner asserts. Further, Patent Owner provides no evidence suggesting the “01.04.08” in the Title entry is a date, or anything other than merely part of the Title of the document.

Based on the evidence before us, we observe that the Mozgrin Thesis was cataloged and indexed in a meaningful way, by the author’s name, the title of the thesis (“High-Current Low-Pressure Quasi-Stationary Discharge in a Magnetic Field”), and the subject matter of the thesis (“Plasma Physics and Chemistry”). Ex. 1209. As such, the catalog entry demonstrates that the Mozgrin Thesis was made available to interested persons by virtue of its title and “Subject” characterization. Upon consideration of the facts before us, we determine that the Russian State Library’s catalog entry is credible evidence to establish that the Mozgrin Thesis was made sufficiently accessible to the public interested in the art before the critical date of November 14, 2002. Accordingly, based on the totality of the circumstances, we are persuaded that Petitioner has established sufficiently that the Mozgrin Thesis is a printed publication under § 102.

Given the evidence in the record before us, we determine that Petitioner has demonstrated, by a preponderance of evidence, that each of

IPR2014-00802  
Patent 7,811,421 B2

claims 14, 26, and 37 would have been obvious in view of Wang and Mozgrin Thesis.

### III. CONCLUSION

For the foregoing reasons, we determine that Petitioner has demonstrated, by a preponderance of the evidence, that claims 9, 21, and 35 of the '421 patent are unpatentable under 35 U.S.C. § 103 as obvious in view of Wang and Kudryavtsev, and that claims 14, 26, and 37 of the '421 patent are unpatentable under 35 U.S.C. § 103 as obvious in view of Wang and Mozgrin Thesis.

### IV. ORDER

Accordingly, it is:

ORDERED that claims 9, 14, 21, 26, 35, and 37 of U.S. Patent No. 7,811,421 B2 are held *unpatentable*; and

FURTHER ORDERED that, because this is a Final Written Decision, parties to the proceeding seeking judicial review of the decision must comply with the notice and service requirements of 37 C.F.R. § 90.2.



STEPHENS, *Administrative Patent Judge, dissenting-in-part.*

I respectfully disagree with the Majority's determination that the Mozgrin Thesis is prior art under 35 U.S.C. § 102(b). For a reference to qualify as a printed publication within the meaning of § 102, "the reference must have been sufficiently accessible to the public interested in the art," before the critical date. *In re Cronyn*, 890 F.2d 1158, 1160 (Fed. Cir. 1989) (quoting *Constant v. Adv. Micro-Devices, Inc.*, 848 F.2d 1560, 1568 (Fed. Cir. 1988)).

Patent Owner argues Petitioner failed to show the Mozgrin Thesis was disseminated or otherwise made available to interested persons as a printed publication more than one year prior to the filing date of the '421 patent. PO Resp. 45–48. Specifically, Patent Owner argues the catalog entry does not indicate the Mozgrin Thesis was available prior to the filing date of the '421 patent. *Id.*

"Because there are many ways in which a reference may be disseminated to the interested public, 'public accessibility' has been called the touchstone in determining whether a reference constitutes a 'printed publication' bar under 35 U.S.C. § 102(b)." *In re Hall*, 781 F.2d 897, 898–99 (Fed. Cir. 1986).

I am not persuaded Petitioner has shown the Mozgrin Thesis was publicly accessible *more than one year prior to the date of the application* for patent. Specifically, Petitioner relies on a catalog entry from the Russian State Library's catalog of dissertations, which includes the holdings, the author, the title, the imprint (1994), the description, and the subject matter.

Ex. 1209, 1; Reply 19. Petitioner additionally asserts the Mozgrin Thesis was shelved and indexed in the catalog of the library. Reply 19. Petitioner further contends Exhibit 1209 “shows it is the routine business practice of the library to index and catalog theses.” Reply 20. However, nothing in the catalog entry speaks to the date on which the Mozgrin Thesis was incorporated into the Russian State Library’s catalog of dissertations or shelved, or even that the Russian State Library catalog of dissertations existed at the time of invention. As our reviewing court has stated, “[a]lthough ‘evidence establishing a *specific* date of cataloging’ was not required in *Hall*, in that case we held that ‘competent evidence of the general library practice’ of cataloging and shelving established that the thesis became accessible prior to the critical date.” *In re Lister*, 583 F.3d 1307, 1316 (Fed. Cir. 2009) (vacating and remanding the Board of Patent Appeals and Interferences’ decision that a prior art reference registered with the U.S. Copyright Office and included in the Westlaw and Dialog databases was publicly accessible for the purposes of 35 U.S.C. § 102(b)). Here, neither the imprint date nor the labeling indicates the Mozgrin Thesis was publicly accessible prior to the critical date. Further, Petitioner “has not identified any evidence of the general practice” of the Russian State Library with regard to catalog updates or shelving of received dissertations. *See id.* at 1316–17. Therefore, absent any evidence pertaining to when the Russian State Library received the Mozgrin Thesis, when the publicly accessible catalog was available, and what the general practices of the Russian State Library between receipt of a thesis and subsequent incorporation into a

publicly accessible catalog are, the presumption the Mozgrin Thesis was publicly accessible more than one year prior to the date of the application for patent is pure speculation. *See id.* at 1316.

Petitioner further argues Zond waived its objection to the Mozgrin Thesis and the electronic card catalog printout. Reply 20. I respectfully disagree Patent Owner was required to object under 37 C.F.R. § 42.64(b). Significantly, Patent Owner does not contend that the Mozgrin Thesis is inadmissible under any Federal Rule of Evidence. Instead, Patent Owner argues the Mozgrin Thesis is not prior art under 35 U.S.C. § 102(b) because Petitioner has not shown the Mozgrin Thesis was publicly accessible — a challenge to the sufficiency or weight to be given to the Mozgrin Thesis. Such argument is not proper in a motion to exclude, which is a challenge to the admissibility of evidence, not a challenge to sufficiency. *See Office Patent Trial Practice Guide*, 77 Fed. Reg. 48,756, 48,767 (August 14, 2012) (stating that a motion to exclude may not be used to challenge the sufficiency of the evidence to prove a particular fact).

Patent Owner properly provided arguments in the preliminary response and response asserting Petitioner has not sufficiently demonstrated that the Mozgrin Thesis is prior art under 35 U.S.C. § 102(b). Accordingly, I am not persuaded Petitioner has established sufficiently that the Mozgrin Thesis is a printed publication under 35 U.S.C. § 102(b). It follows, I am not persuaded claims 14, 26, and 37 are unpatentable under § 103(a) as obvious over the combination of Wang and Mozgrin Thesis.

IPR2014-00802  
Patent 7,811,421 B2

For PATENT OWNER:

Bruce J. Barker  
[bbarker@chsblaw.com](mailto:bbarker@chsblaw.com)

Tarek Fahmi  
[tarek.fahmi@ascendalaw.com](mailto:tarek.fahmi@ascendalaw.com)

Gregory J. Gonsalves  
[gonsalves@gonsalveslawfirm.com](mailto:gonsalves@gonsalveslawfirm.com)

For PETITIONERS:

*Fujitsu:*

David L. McCombs  
[david.mccombs.ipr@haynesboone.com](mailto:david.mccombs.ipr@haynesboone.com)

David M O'Dell  
[david.odell.ipr@haynesboone.com](mailto:david.odell.ipr@haynesboone.com)

Richard C. Kim  
[rckim@duanemorris.com](mailto:rckim@duanemorris.com)

*AMD:*

Brian M. Berliner  
[bberliner@omm.com](mailto:bberliner@omm.com)

Ryan K. Yagura  
[ryagura@omm.com](mailto:ryagura@omm.com)

Xin-Yi Zhou  
[vzhou@omm.com](mailto:vzhou@omm.com)

*Renesas:*

John J. Feldhaus  
[jfeldhaus@foley.com](mailto:jfeldhaus@foley.com)

IPR2014-00802  
Patent 7,811,421 B2

Pavan Agarwal  
[pagarwal@foley.com](mailto:pagarwal@foley.com)

Mike Houston  
[mhouston@foley.com](mailto:mhouston@foley.com)

*GlobalFoundries:*

David Tennant  
[dtennant@whitecase.com](mailto:dtennant@whitecase.com)

Dohm Chankong  
[dohm.chankong@whitecase.com](mailto:dohm.chankong@whitecase.com)

*Toshiba:*

Robinson Vu  
[Robinson.vu@bakerbotts.com](mailto:Robinson.vu@bakerbotts.com)

*Gillette:*

Michael A. Diener  
[michael.diener@wilmerhale.com](mailto:michael.diener@wilmerhale.com)

Larissa B. Park  
[larissa.park@wilmerhale.com](mailto:larissa.park@wilmerhale.com)