

UNITED STATES PATENT AND TRADEMARK OFFICE

BEFORE THE PATENT TRIAL AND APPEAL BOARD

FUJITSU SEMICONDUCTOR LIMITED, FUJITSU SEMICONDUCTOR AMERICA, INC., ADVANCED MICRO DEVICES, INC., RENESAS ELECTRONICS CORPORATION, RENESAS ELECTRONICS AMERICA, INC., GLOBALFOUNDRIES U.S., INC., GLOBALFOUNDRIES DRESDEN MODULE ONE LLC & CO. KG, GLOBALFOUNDRIES DRESDEN MODULE TWO LLC & CO. KG, TOSHIBA AMERICA ELECTRONIC COMPONENTS, INC., TOSHIBA AMERICA INC., TOSHIBA AMERICA INFORMATION SYSTEMS, INC., TOSHIBA CORPORATION, and THE GILLETTE COMPANY,
Petitioner,

v.

ZOND, LLC,
Patent Owner.

Case IPR2014-00800¹
Patent 7,811,421 B2

Before KEVIN F. TURNER, DEBRA K. STEPHENS, JONI Y. CHANG, SUSAN L. C. MITCHELL, and JENNIFER MEYER CHAGNON,
Administrative Patent Judges.

CHAGNON, *Administrative Patent Judge.*

FINAL WRITTEN DECISION
Inter Partes Review

¹ Cases IPR2014-00844, IPR2014-00991, and IPR2014-01037 have been joined with the instant proceeding.

IPR2014-00800
Patent 7,811,421 B2

35 U.S.C. § 318(a) and 37 C.F.R. § 42.73

I. INTRODUCTION

We have jurisdiction to hear this *inter partes* review under 35 U.S.C. § 6(c). This Final Written Decision is issued pursuant to 35 U.S.C. § 318(a) and 37 C.F.R. § 42.73. For the reasons discussed herein, we determine that Petitioner has shown by a preponderance of the evidence that claims 1, 2, 8, 10–13, 15–17, 22–25, 27–30, 33, 34, 38, 39, 42, 43, and 46–48 of U.S. Patent No. 7,811,421 B2 (Ex. 1001, “the ’421 patent”) are unpatentable.

A. Procedural History

Taiwan Semiconductor Manufacturing Company, Ltd. and TSMC North America Corp. (collectively, “TSMC”) filed a Petition (Paper 1, “Pet.”) seeking *inter partes* review of claims 1, 2, 8, 10–13, 15–17, 22–25, 27–30, 33, 34, 38, 39, 42, 43, and 46–38 (“the challenged claims”) of the ’421 patent. TSMC included a Declaration of Uwe Kortshagen, Ph.D. (Ex. 1002) to support its positions. Zond (“Patent Owner”) filed a Preliminary Response (Paper 7, “Prelim. Resp.”). Pursuant to 35 U.S.C. § 314(a), on October 6, 2014, we instituted an *inter partes* review of the challenged claims to determine if claims 1, 2, 8, 10–13, 16, 17, 22–25, 28–30, 33, 34, 39, 42, 43, and 46–48 are unpatentable under 35 U.S.C. § 102 as anticipated by Wang,² and if claims 15, 27, and 38 are unpatentable under 35 U.S.C. § 103 as obvious over the combination of Wang and Mozgrin.³ Paper 9 (“Inst. Dec.”).

² U.S. Patent No. 6,413,382 B1, issued July 2, 2002 (Ex. 1004).

³ D.V. Mozgrin et al., *High-Current Low-Pressure Quasi-Stationary*

Subsequent to institution, we granted revised Motions for Joinder filed by other Petitioners listed in the Caption above, joining Cases IPR2014-00844, IPR2014-00991, and IPR2014-01037 with the instant trial (Papers 12, 13), and also granted a Joint Motion to Terminate with respect to TSMC (Paper 32).⁴ Patent Owner filed a Patent Owner Response (Paper 27, “PO Resp.”), along with a Declaration of Larry D. Hartsough, Ph.D. (Ex. 2015) to support its positions. Petitioner filed a Reply (Paper 45, “Reply”) to the Patent Owner Response, along with a Declaration of Lawrence J. Overzet, Ph.D. (Ex. 1027). An oral hearing⁵ was held on June 8, 2015. A transcript of the hearing is included in the record. Paper 54 (“Tr.”).

B. Related Proceedings

The parties indicate that the ’421 patent was asserted against Petitioner, as well as other defendants, in seven district court lawsuits pending in the District of Massachusetts. Pet. 1; Paper 5.

C. The ’421 Patent

The ’421 patent relates to a method and apparatus for high-deposition sputtering. Ex. 1001, Abstract. At the time of the invention, sputtering was

Discharge in a Magnetic Field: Experimental Research, 21 PLASMA PHYSICS REPORTS 400–409 (1995) (Ex. 1003).

⁴ We refer to the remaining parties, listed in the Caption above, collectively, as “Petitioner” throughout this Decision.

⁵ The oral arguments for IPR2014-00781, IPR2014-00782, IPR2014-00800, IPR2014-00802, IPR2014-00805, IPR2014-01083, IPR2014-01086, and IPR2014-01087 were consolidated.

a well-known technique for depositing films on semiconductor substrates. *Id.* at 1:15–16. As discussed in the '421 patent, prior art magnetron sputtering systems deposited films having low uniformity, poor target utilization (the target material erodes in a non-uniform manner), and relatively low deposition rate (low amount of material deposited on the substrate per unit time). *Id.* at 1:63–2:14. The '421 patent discloses that increasing the power applied to the plasma, in an attempt to increase the target utilization and sputtering yield, can also “increase[] the probability of establishing an undesirable electrical discharge (an electrical arc) in the process chamber.” *Id.* at 3:20–29.

The '421 patent further discloses that using pulsed power can reduce the probability of establishing an electrical breakdown condition, but that large power pulses still can result in undesirable electrical discharges. *Id.* at 3:30–38. According to the '421 patent, however, first forming a weakly-ionized plasma “substantially eliminates the probability of establishing a breakdown condition in the chamber . . . when high-power pulses are applied between the cathode . . . and the anode.” *Id.* at 9:16–19. Once a weakly-ionized plasma is formed, high-power pulses are applied between the cathode and anode to generate a strongly-ionized plasma from the weakly-ionized plasma. *Id.* at 9:29–31, 10:8–9. The “probability of establishing a breakdown condition is substantially eliminated because the weakly-ionized plasma has a low-level of ionization that provides electrical conductivity through the plasma. This conductivity greatly reduces or

prevents the possibility of a breakdown condition, even when high power is applied to the plasma.” *Id.* at 9:23–28.

D. Illustrative Claim

Of the challenged claims, claims 1, 17, 34, and 46–48 are independent. Claims 2, 8, 10–13, 15, and 16 depend from claim 1. Claims 22–25, 27–30, and 33 depend from claim 17. Claims 38, 39, 42, and 43 depend from claim 34. Claim 1 is illustrative, and is reproduced as follows:

1. A sputtering source comprising:
 - a) a cathode assembly comprising a sputtering target that is positioned adjacent to an anode; and
 - b) a power supply that generates a voltage pulse between the anode and the cathode assembly that creates a weakly-ionized plasma and then a strongly-ionized plasma from the weakly-ionized plasma without an occurrence of arcing between the anode and the cathode assembly, an amplitude, a duration and a rise time of the voltage pulse being chosen to increase a density of ions in the strongly-ionized plasma.

Ex. 1001, 22:14–24.

II. ANALYSIS

A. Claim Construction

In an *inter partes* review, claim terms in an unexpired patent are given their broadest reasonable construction in light of the specification of the patent in which they appear. 37 C.F.R. § 42.100(b); *see In re Cuozzo Speed Techs., LLC*, 793 F.3d 1268, 1275–79 (Fed. Cir. 2015). Claim terms generally are given their ordinary and customary meaning as would be understood by one of ordinary skill in the art in the context of the entire

disclosure. *In re Translogic Tech., Inc.*, 504 F.3d 1249, 1257 (Fed. Cir. 2007). Significantly, claims are not interpreted in a vacuum but are part of, and read in light of, the specification. *United States v. Adams*, 383 U.S. 39, 49 (1966) (“[I]t is fundamental that claims are to be construed in the light of the specifications and both are to be read with a view to ascertaining the invention.”) (citations omitted).

An inventor may provide a special definition of the term in the specification, as long as this is done so “with reasonable clarity, deliberateness, and precision.” *In re Paulsen*, 30 F.3d 1475, 1480 (Fed. Cir. 1994). In the absence of such a definition, however, limitations are not to be read from the specification into the claims. *In re Van Geuns*, 988 F.2d 1181, 1184 (Fed. Cir. 1993).

Claim Terms

“*weakly-ionized plasma*” and “*strongly-ionized plasma*”

Each of the independent claims recites “creat[ing] a *weakly-ionized plasma* and then a *strongly-ionized plasma* from the weakly-ionized plasma.” Ex. 1001, 22:18–20, 23:14–16, 24:17–19, 25:5–7, 25:16–26:2, 26:10–12. In our Institution Decision, we adopted Patent Owner’s proposed constructions, in light of the Specification, as the broadest reasonable interpretation of each of these claim terms. Inst. Dec. 8–10; *see, e.g.*, Ex. 1001, 9:24–25 (“the weakly-ionized plasma 232 has a low-level of ionization”), 12:11–12 (“The strongly-ionized plasma 268 is also referred to as a high-density plasma.”). Neither party has challenged our claim constructions as to these terms. PO Resp. 16–17; Ex. 2015 ¶ 20; Reply 2;

Ex. 1027 ¶¶ 26–28. Upon consideration of the complete record now before us, we discern no reason to change our claim constructions set forth in the Institution Decision with respect to these claim terms. *See* Inst. Dec. 8–10. Therefore, we construe, in light of the Specification, the claim term “a weakly-ionized plasma” as “a plasma with a relatively low peak density of ions,” and the claim term “a strongly-ionized plasma” as “a plasma with a relatively high peak density of ions.”

“without an occurrence of arcing”

Each of the independent claims recites “creat[ing] a weakly-ionized plasma and then a strongly-ionized plasma from the weakly-ionized plasma *without an occurrence of arcing* between the anode and the cathode assembly.” Ex. 1001, 22:18–22, 23:14–18, 24:17–20, 25:5–9, 25:16–26:4, 26:10–14. We did not provide an express construction of the claim term “without an occurrence of arcing” in our Institution Decision. The Specification of the ’421 patent does not recite or explicitly define this claim term. Rather, it discloses a process that *reduces or substantially eliminates the possibility of* the occurrence of arcing when high-power pulses are applied to a pre-ionized plasma.

For instance, the Specification of the ’421 patent discloses:

Forming a weakly-ionized or pre-ionized plasma *substantially eliminates the probability* of establishing a breakdown condition in the chamber 202 when high-power pulses are applied between the cathode assembly 216 and the anode 238. . . . *The probability of establishing a breakdown condition is substantially eliminated* because the weakly-ionized plasma has a low-level of ionization that provides

electrical conductivity through the plasma. This conductivity *greatly reduces or prevents the possibility of a breakdown condition* when high power is applied to the plasma.

Id. at 9:16–28 (emphases added).

As described herein, the formation of weakly-ionized plasma 262 *substantially eliminates the possibility of creating a breakdown condition* when high-power pulses are applied to the weakly-ionized plasma 262. The suppression of this breakdown condition *substantially eliminates the occurrence of undesirable arcing* between the anode 238 and the cathode assembly 216.

Id. at 15:66–16:5 (emphases added).

In its Response, Patent Owner argues both that the claims require creation of the weakly-ionized plasma without an occurrence of arcing (*see, e.g.,* PO Resp. 11, 14, 16, 18, 28; Tr. 59:22–62:7), and that “[w]hile the presence of pre-ionized plasma in figure 6 [of Wang] reduces the likelihood of arcing, Wang never says that the background power P_B entirely eliminated arcing after ignition” (PO Resp. 33, citations omitted).

We first address Patent Owner’s argument that the claims require no arcing during creation of the weakly-ionized plasma. Here, Patent Owner improperly attempts to import extraneous limitations into the claim by arguing repeatedly that the claims require that arcing is avoided, *even on plasma ignition. See, e.g.,* PO Resp. 11, 14, 16, 18, 28; Tr. 59:22–62:7. Patent Owner’s interpretation, however, is not consistent with the language of the claims, particularly when considered in view of the Specification. The plain claim language of the independent claims, which recite “creat[ing] a weakly-ionized plasma and then a strongly-ionized plasma without an

occurrence of arcing,” supports a claim construction where the claim phrase “without an occurrence of arcing” modifies only the portion of the claim reciting the transition to a strongly-ionized plasma from a weakly-ionized plasma. Further, as seen in the quoted portions of the Specification set forth above, the Specification of the ’421 patent describes the weakly-ionized plasma as substantially eliminating the setup of a breakdown condition, and thus arcing, *when the high-power pulses are applied across the weakly-ionized plasma* to generate a strongly-ionized plasma from the weakly-ionized plasma; the Specification does not support Patent Owner’s assertion that the setup of a breakdown condition, or arcing, also be substantially eliminated *when the weakly-ionized plasma itself is formed*. In fact, the Specification indicates that it is the presence of the weakly-ionized plasma that provides for the ability to substantially eliminate arcing when the high-power pulses are applied. *See* Ex. 1001, 9:16–28, 15:66–16:5. Accordingly, we decline to construe the claims to require creation of the weakly-ionized plasma without an occurrence of arcing. *See In re NTP, Inc.*, 654 F.3d 1279, 1288 (Fed. Cir. 2011) (stating that the Board’s claim construction “cannot be divorced from the specification and the record evidence”); *see also In re Cortright*, 165 F.3d 1353, 1358 (Fed. Cir. 1999) (stating that the Board’s claim construction “must be consistent with the one that those skilled in the art would reach”).

We now address Patent Owner’s focus on the distinction between reducing versus eliminating. *See* PO Resp. 33. Patent Owner does not explain adequately why *one with ordinary skill in the plasma art* would have

interpreted the claim term “without developing an electrical breakdown condition,” *in light of the Specification*, to require the transformation of the weakly-ionized plasma to a strongly-ionized plasma with a guarantee of eliminating *all possibility* of arcing. See *In re NTP, Inc.*, 654 F.3d at 1288; *In re Cortright*, 165 F.3d at 1358. One with ordinary skill in the art would have recognized that electrical arcing in a real-world plasma sputtering apparatus occurs naturally under certain processing conditions. In this regard, Dr. Overzet testifies that “[a] person of skill in the art would recognize that arcing is undesirable and it is always the goal to completely prevent arcing from occurring. However, *it is not possible to construct a perfect system and there is always a possibility that a system will arc.*” Ex. 1027 ¶ 51 (emphases added). We credit the testimony of Dr. Overzet as it is consistent with the Specification of the ’421 patent, which discloses only that the possibility of arcing is “substantially eliminated” or “greatly reduced.” Ex. 1001, 9:16–28, 15:66–16:5.

It is well settled that “[a] claim construction that excludes the preferred embodiment is rarely, if ever, correct and would require highly persuasive evidentiary support.” *Adams Respiratory Therapeutics, Inc. v. Perrigo Co.*, 616 F.3d 1283, 1290 (Fed. Cir. 2010) (internal quotations omitted). A construction that excludes all disclosed embodiments, as urged by Patent Owner here, is especially disfavored. *MBO Labs., Inc. v. Becton, Dickinson & Co.*, 474 F.3d 1323, 1333 (Fed. Cir. 2007). In short, claim construction requires claim terms to be read so that they encompass the very

preferred embodiment they describe. *On-Line Techs., Inc. v. Bodenseewerk Perkin-Elmer GmbH*, 386 F.3d 1133, 1138 (Fed. Cir. 2004).

Here, nothing in the Specification indicates that the possibility of arcing is *completely eliminated* when the weakly-ionized plasma is transformed to a strongly-ionized plasma. Rather, it explicitly states that “the formation of weakly-ionized plasma 262 *substantially eliminates* the possibility of creating a breakdown condition when high-power pulses are applied to the weakly-ionized plasma 262,” and “[t]he suppression of this breakdown condition *substantially eliminates* the occurrence of undesirable arcing between the anode 238 and the cathode assembly 216.” Ex. 1001, 15:66–16:5 (emphases added).

Given the disclosure in the Specification, we decline to construe the claims to require the transformation of the weakly-ionized plasma to a strongly-ionized plasma occur with a *guarantee* of eliminating *all possibility* of an electrical breakdown condition or arcing, because it would be unreasonable to exclude the disclosed embodiments, all of which stop short of such a guarantee. *See Phillips v. AWH Corp.*, 415 F.3d 1303, 1315 (Fed. Cir. 2005) (en banc) (stating that the Specification is “the single best guide to the meaning of a disputed term”). Instead, we construe the claim term “without developing an electrical breakdown condition in the chamber” as “substantially eliminating the possibility of developing an electrical breakdown condition in the chamber,” consistent with an interpretation that one of ordinary skill in the art would reach when reading the claim term in the context of the Specification. Additionally, as noted above, we also

decline to construe the claims to require formation of the weakly-ionized plasma without an occurrence of arcing, and instead, consistent with the Specification of the '421 patent, determine the “without an occurrence of arcing” language modifies only the creation of the strongly-ionized plasma from the weakly-ionized plasma.

“creates a weakly-ionized plasma and then a strongly-ionized plasma from the weakly-ionized plasma”

Each of the independent claims recites “a voltage pulse . . . that *creates* a weakly-ionized plasma and then a strongly-ionized plasma from the weakly-ionized plasma.”⁶ Ex. 1001, 22:18–20, 23:14–16, 25:5–7, 25:16–26:2, 26:10–12. We did not provide an express construction of the term “creates” in our Institution Decision.

In its Response, Patent Owner proposes the phrase “creates a weakly-ionized plasma” should be interpreted as “ignites a gas from a state in which there is no plasma to a state in which a plasma exists, wherein the plasma is initially a weakly-ionized plasma” PO Resp. 22. In support of its proposed construction, Patent Owner identifies the following portions of the Specification in support of its construction (PO Resp. 18):

⁶ Claim 34 recites, similarly, a “voltage pulse *creating* a weakly-ionized plasma and then a strongly-ionized plasma from the weakly-ionized plasma.” Ex. 1001, 24:17–19.

In operation, the pulsed power supply 102 applies a voltage pulse between the cathode assembly 114 and the anode 130 that has a sufficient amplitude to ionize the argon feed gas in the vacuum chamber 104.

Ex. 1001, 4:13–15.

The amplitude and shape of the voltage pulse are such that a weakly-ionized plasma is generated in the region 246 between the anode 238 and the cathode assembly 216.

Id. at 8:19–21.

In one embodiment, the pulsed power supply 234 generates a low power pulse . . . in order to generate the weakly-ionized plasma.

Id. at 8:29–34.

Patent Owner also cites to Dr. Kortshagen’s deposition, in which he testified the mechanism of the “creation of a plasma” is “typically referred to as ignition of the plasma where you go from a state where you do not have a plasma present to a state where you now have a plasma present.” PO Resp. 19; Ex. 2017, 12:13–24. Patent Owner further contends that Petitioner’s discussion of Wang in the Petition suggests Petitioner uses “creates a weakly-ionized plasma” to refer to “ignition of a gas to cause a plasma to come into existence.” PO Resp. 19–20.

Petitioner argues that Patent Owner’s proposed construction improperly reads an “ignite” limitation into the claims. Reply 2. Petitioner argues the Specification of the ’421 patent describes other embodiments that support a broader interpretation of “creates,” and proposes the term should be construed to have its plain and ordinary meaning or an explicit

construction of “forms or generates.” *Id.* at 3–4 (citing Ex. 1001, 16:42–44, 16:48–51).

Initially, we note Patent Owner has not identified, nor do we find, any portion of the Specification of the ’421 patent that explicitly defines the term “creates.” The ’421 patent describes choosing characteristics of a voltage pulse such that an electric field develops that creates a weakly-ionized plasma. Ex. 1001, 11:14–20. However, the ’421 patent also uses the term “creates” in various other contexts. For example, the ’421 patent describes strongly-ionized plasma tends to diffuse homogenously in region 264, which “creates a more homogeneous plasma volume,” and the high power pulse “creates strongly-ionized plasma.” *Id.* at 12:16–19, 20:22–24. The ’421 patent further describes an initial voltage that “creates a plasma discharge voltage.” *Id.* at 8:53–56.

We are not persuaded by Patent Owner’s contention that one of ordinary skill in the art would interpret “creates a weakly-ionized plasma” as suggested (PO Resp. 18–22). In its Motion on Observations, Patent Owner further argues that Dr. Overzet’s deposition testimony supports its proposed construction. Paper 48, 1–5. We are not persuaded, however, that Dr. Overzet’s cited testimony supports Patent Owner’s proposal, nor is it necessary for construction of the claims; instead, we determine the meaning of the claim limitation is apparent from the intrinsic evidence alone.

Based on the evidence before us, we determine that “creates” would be understood by one of ordinary skill in the art to mean “to bring into existence,” consistent with the use of the word in the Specification and the

plain and ordinary meaning thereof. *See Create Definition*, Merriam-Webster's Collegiate Dictionary 271 (10th edition 2000). Furthermore, the '421 patent does not explicitly define "creates a weakly-ionized plasma." While Patent Owner provides examples described in the Specification (PO Resp. 18), we will not import the suggested "ignition" limitation into the claim. *See Renishaw PLC v. Marposs Societa' per Azioni*, 158 F.3d 1243, 1248 (Fed. Cir. 1998); *see also, SuperGuide Corp. v. DirecTV Enters., Inc.*, 358 F.3d 870, 875 (Fed. Cir. 2004) ("Though understanding the claim language may be aided by the explanations contained in the written description, it is important not to import into a claim limitations that are not a part of the claim.").

As such, we interpret the term "creates a weakly-ionized plasma" as "brings into existence a weakly-ionized plasma," and do not limit the claim to a circumstance that the gas is ignited from a state in which there is no existing plasma, as proposed by Patent Owner.

"pulse"

Each of claims 1, 17, and 46–48 recites "a power supply that generates a voltage pulse."⁷ Ex. 1001, 22:17, 23:13, 25:4, 25:15, 26:9. Patent Owner asserts the term "pulse" should be given its ordinary meaning, but does not proffer any "formal construction." PO Resp. 17. Petitioner proposes we construe "pulse" as "a property (e.g., voltage, current, or power) that is applied over a period of time." Reply 6.

⁷ Claim 34 recites, similarly, "generating a voltage pulse." Ex. 1001, 24:15.

The parties' dispute with respect to this term focuses on the application of the cited art to the claims, rather than on a particular meaning of the term itself. For this reason, we do not provide an express construction for this term. Instead, we address the parties' arguments regarding the usage of the term "pulse" in more detail below, in the context of applying the cited art to the claims.

B. Principles of Law

To prevail in its challenges to the patentability of the claims, Petitioner must prove unpatentability by a preponderance of the evidence. 35 U.S.C. § 316(e); 37 C.F.R. § 42.1(d). A claim is unpatentable under 35 U.S.C. § 102 if a single prior art reference expressly or inherently describes each and every limitation set forth in the claim. *See Perricone v. Medicis Pharm. Corp.*, 432 F.3d 1368, 1375 (Fed. Cir. 2005); *Verdegaal Bros., Inc. v. Union Oil Co.*, 814 F.2d 628, 631 (Fed. Cir. 1987).

A claim is unpatentable under 35 U.S.C. § 103 if the differences between the claimed subject matter and the prior art are such that the subject matter, as a whole, would have been obvious at the time the invention was made to a person having ordinary skill in the art to which said subject matter pertains. *KSR Int'l Co. v. Teleflex Inc.*, 550 U.S. 398, 406 (2007).

The question of obviousness is resolved on the basis of underlying factual determinations including: (1) the scope and content of the prior art; (2) any differences between the claimed subject matter and the prior art; (3) the level of ordinary skill in the art; and (4) objective evidence of nonobviousness. *Graham v. John Deere Co.*, 383 U.S. 1, 17–18 (1966).

In that regard, an obviousness analysis “need not seek out precise teachings directed to the specific subject matter of the challenged claim, for a court can take account of the inferences and creative steps that a person of ordinary skill in the art would employ.” *KSR*, 550 U.S. at 418; *see Translogic*, 504 F.3d at 1259. A prima facie case of obviousness is established when the prior art itself would appear to have suggested the claimed subject matter to a person of ordinary skill in the art. *In re Rinehart*, 531 F.2d 1048, 1051 (CCPA 1976). The level of ordinary skill in the art is reflected by the prior art of record. *See Okajima v. Bourdeau*, 261 F.3d 1350, 1355 (Fed. Cir. 2001); *In re GPAC Inc.*, 57 F.3d 1573, 1579 (Fed. Cir. 1995); *In re Oelrich*, 579 F.2d 86, 91 (CCPA 1978).

We analyze the asserted grounds of unpatentability in accordance with the above-stated principles.

C. Anticipation by Wang

Petitioner asserts that each of claims 1, 2, 8, 10–13, 16, 17, 22–25, 38–30, 33, 34, 39, 42, 43, and 46–48 is unpatentable under 35 U.S.C. § 102 as anticipated by Wang. Pet. 33–50. Petitioner explains how each claim limitation is disclosed in Wang. *Id.* Petitioner also relies on the Declarations of Dr. Kortshagen (Ex. 1002) and Dr. Overzet (Ex. 1027) to support its Petition and Reply, respectively. Patent Owner responds that Wang does not disclose every claim element, relying on the Declaration of Dr. Hartsough (Ex. 2015) to support its Response. PO Resp. 23–50.

We have reviewed the entire record before us, including the parties’ explanations and supporting evidence presented during this trial. We begin

our discussion with a brief summary of Wang, and then we address the parties' contentions in turn.

Wang

Wang discloses a power pulsed magnetron sputtering method for generating a very high plasma density. Ex. 1004, Abstract. Wang also discloses a sputtering method for depositing metal layers onto advanced semiconductor integrated circuit structures. *Id.* at 1:4–15.

Figure 1 of Wang, reproduced below, illustrates a cross-sectional view of a magnetron sputtering reactor:

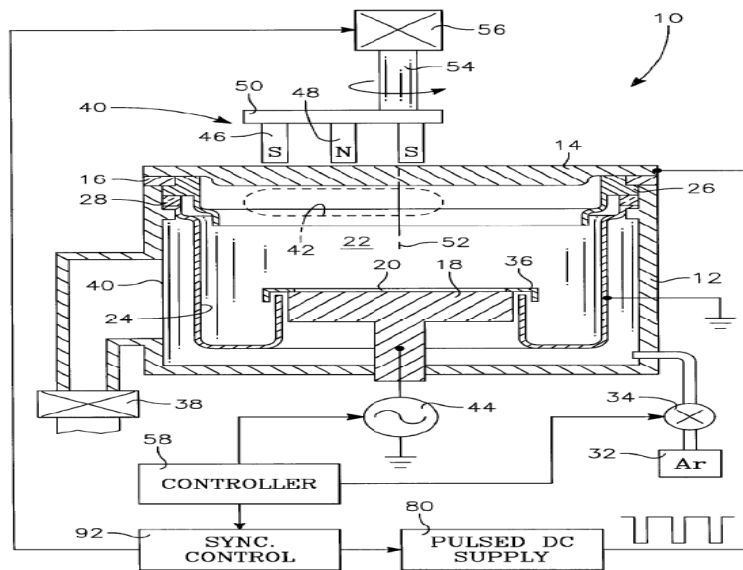

FIG. 1

As shown in Figure 1 of Wang, magnetron sputtering apparatus 10 has pedestal 18 for supporting semiconductor substrate 20, anode 24, cathode 14, magnet assembly 40, and pulsed DC power supply 80. Ex. 1004, 3:57–4:55. According to Wang, the apparatus creates high-density plasma in region 42, which ionizes a substantial fraction of the sputtered particles into

positively charged metal ions and also increases the sputtering rate. *Id.* at 4:13–34. Magnet assembly 40 creates a magnetic field near target 14, which traps electrons from the plasma to increase the electron density. *Id.* at 4:23–27. Wang further recognizes that, if a large portion of the sputtered particles are ionized, the films are deposited more uniformly and effectively. *Id.* at 1:24–29.

Figure 6 of Wang, reproduced below, illustrates how the apparatus applies a pulsed power to the plasma:

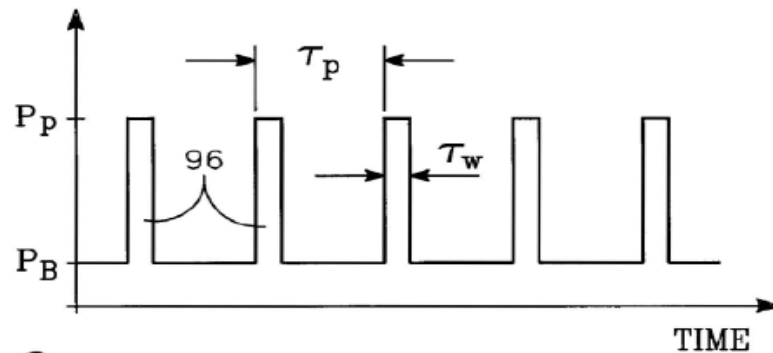

FIG. 6

As shown in Figure 6 of Wang, the target is maintained at background power level P_B between high power pulses 96 with peak power level P_p . Ex. 1004, 7:13–39. Background power level P_B exceeds the minimum power necessary to support a plasma in the chamber at the operational pressure (e.g., 1 kW). *Id.* Peak power P_p is at least 10 times (preferably 100 or 1000 times) background power level P_B . *Id.* The application of high peak power P_p causes the existing plasma to spread quickly, and increases the density of the plasma. *Id.* According to Dr. Kortshagen, Wang's apparatus generates a low-density (weakly-ionized) plasma during the application of

background power P_B , and a high-density plasma during the application of peak power P_P . Ex. 1002 ¶ 100; *see* Pet. 35–36. In Wang, background power P_B may be generated by DC power supply 100 and peak power P_P may be generated by pulsed power supply 80. Ex. 1004, 7:56–64, Fig. 7; Ex. 1002 ¶ 40.

Independent Claims 1, 17, 34, and 46–48

As indicated above, Petitioner explains how each limitation of the independent claims is disclosed in Wang. Pet. 33–44. For example, regarding claim 1, Petitioner contends that anode 24 and the cathode assembly, including sputtering target 14, of Wang disclose the claimed cathode assembly adjacent an anode. *Id.* at 33–34; Ex. 1004, 3:33–4:1; Ex. 1002 ¶ 96. Petitioner further contends that the combination of DC power supply 100 and pulsed DC power supply 80, the outputs of each of being coupled to cathode target 14, discloses the claimed power supply that generates a voltage pulse. Pet. 34–35; Ex. 1004, 3:66–4:1, 7:58–62, Figs. 1, 6, 7; Ex. 1002 ¶¶ 97–99. According to Petitioner, DC power supply 100 of Wang supplies background power P_B that generates a low density plasma, thus disclosing creating a weakly-ionized plasma, and pulsed DC power supply 80 of Wang supplies peak power P_P that generates a high density plasma from the weakly-ionized plasma, thus disclosing creating a strongly-ionized plasma. Pet. 35–36; Ex. 1004, 7:17–39; Ex. 1002 ¶¶ 100–101. Petitioner contends that Wang also discloses forming the strongly-ionized plasma without arcing. Pet. 36–37; Ex. 1004, 7:3–6, 7:13–28, 7:47–49, Fig. 6; Ex. 1002 ¶¶ 102–103. Petitioner further contends that Wang

discloses the voltage pulse having an amplitude, duration, and/or rise time to result in an increased density of ions in the strongly-ionized plasma.

Pet. 37–39; Ex. 1004, 5:23–26, 7:19–30; Ex. 1002 ¶¶ 104–105. In its discussion of claims 17, 34, and 46–48, Petitioner primarily refers back to its discussion of corresponding limitations of claim 1. *See* Pet. 39–44.

Regarding claim 17, Petitioner further relies on pedestal electrode 18 and RF power source 44 of Wang as disclosing the claimed substrate support and bias voltage source. Pet. 39–41; Ex. 1004, 3:63–66, 4:32–34; Ex. 1002 ¶¶ 110–111.

With respect to the independent claims, the parties’ dispute mainly centers on: (1) whether Wang discloses the claimed “*power supply that generates a voltage pulse between the anode and the cathode assembly that creates a weakly-ionized plasma and then a strongly-ionized plasma from the weakly-ionized plasma without an occurrence of arcing*”; and (2) whether Wang discloses “an amplitude, a duration [and/or] a rise time of the voltage pulse being *chosen* to increase a density of ions in the strongly-ionized plasma,” as claimed. We address each of these limitations in turn.

“power supply that generates a voltage pulse between the anode and the cathode assembly that creates a weakly-ionized plasma and then a strongly-ionized plasma from the weakly-ionized plasma”

According to Petitioner, “[power] supply 100 [of Wang] generates the voltage used for the background power, P_B , and pulsed [power] supply 80 generates the train of voltage pulses used to produce the peak power, P_P .” Pet. 34 (citing Ex. 1004, 7:58–61). Petitioner continues that the “outputs of pulsed DC power supply 80 and DC power supply 100 are coupled to the

cathode 14,” and the “[c]ombined pulsed DC power supply 80 and DC power supply 100 generate the pulsed waveform illustrated in Figs. 6 and 7.” *Id.* at 34–35 (citing Ex. 1004, Figs. 1, 7; Ex. 1002 ¶ 98). The background power P_B of Wang generates a low-density (i.e., a weakly-ionized plasma) and the peak power P_P generates a high-density plasma (i.e., a strongly-ionized plasma). *Id.* at 35–36 (citing Ex. 1004, 7:17–31; Ex. 1002 ¶ 100).

In its Response, Patent Owner argues that Wang does not disclose a *single* power supply that generates a voltage *pulse* that *creates* a weakly-ionized plasma. We address each emphasized limitation in turn.

Regarding Patent Owner’s arguments that Wang does not disclose “creating” a weakly-ionized plasma, we note these arguments are based on an incorrect construction of “create”—one that improperly imports an “ignition” requirement into the claim—as discussed above. *See supra* Section II.A. We are persuaded that Petitioner has shown sufficiently that Wang discloses bringing a weakly-ionized plasma into existence, which meets the claim language based on the broadest reasonable interpretation thereof. *See, e.g.*, Ex. 1004, 7:17–19 (“The background [power] level P_B is chosen to exceed the minimum power necessary to support a plasma in the chamber at the operational pressure.”); *id.* at Fig. 6.

Regarding Patent Owner’s assertion that the voltage pulse must be generated by a single power supply (PO Resp. 7–13, 26–27, 32–38), we are not persuaded that the claims are so limited. We agree with Petitioner that nothing in the claim language precludes a DC power supply from

contributing to the claimed pulse. *See* Reply 14. Dr. Overzet testifies that the “collection of components shown in Fig. 7 of Wang [e.g., those circled in red in the annotated figure provided below,] fall within the broadest reasonable interpretation of a ‘power supply’ because they work together to provide power to a target.” Reply 10 n.2 (citing Ex. 1027 ¶ 58). The annotated version of Figure 7 of Wang to which Dr. Overzet refers is reproduced below (Ex. 1027 ¶ 57):

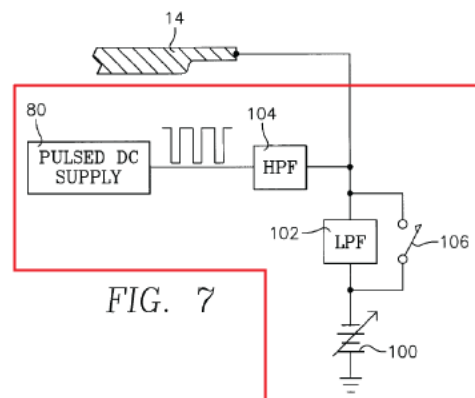

The annotated version of Figure 7, reproduced above, illustrates a combined power supply of Wang. As noted by Dr. Overzet, “properties such as power are additive, which means that they can be combined to produce a desired result.” Ex. 1027 ¶ 57. In this instance, the components circled in red above, cooperate to produce the waveform shown in Figure 6 of Wang, thus disclosing the required power supply. *Id.*; *see* Pet. 34–35. We agree.

We also do not find Patent Owner’s arguments that the background power P_B of Wang does not disclose a “voltage *pulse*,” as claimed, to be persuasive. As discussed above, Petitioner relies on the combination of

background power P_B and peak power P_P as disclosing a waveform corresponding to the claimed “voltage pulse.” *See* Pet. 34–35.

Patent Owner attempts to distinguish between a “continuous” power supply as compared to a “pulsed” power supply. *See, e.g.*, PO Resp. 9–15. However, even Patent Owner’s arguments regarding the claimed “voltage pulse” obfuscate any distinction in this regard. For example, Patent Owner asserts that “[t]he [low power] pulse, by definition has a limited duration called the ‘pulse width.’ But *before the pulse terminates* (i.e., while the weakly ionized plasma is present), the same pulsed power supply 234 increases its power output to transition the weakly ionized plasma to a strongly-ionized plasma.” PO Resp. 12 (emphasis added) (citing Ex. 1001, 8:34–36, 9:29–32, 11:21–26, 11:60–62, Figs. 5A–5D, and related discussion; Ex. 2015 ¶¶ 64–70). It is unclear how a pulse can both have a distinct pulse width, that according to Patent Owner must be present in order to be considered a “pulse,”⁸ and still remain present when the power is increased to transition the weakly-ionized plasma to a strongly-ionized plasma.

Notably, the waveform disclosed in Wang is the same waveform as that of the disclosed embodiments of the ’421 patent. An annotated

⁸ *See, e.g.*, PO Resp. 27 (arguing that Wang does not disclose “termination of the DC power supply’s output or a ‘pulse width’ of that output” and that, thus, the “output emitted by the DC supply [of Wang] is not a pulse having a chosen duration, but is instead a continuous power as shown by the baseline in figure 6”).

comparison of Figure 6 of the '421 patent and Figure 6 of Wang, provided by Dr. Overzet (Ex. 1027 ¶ 38), is reproduced below.

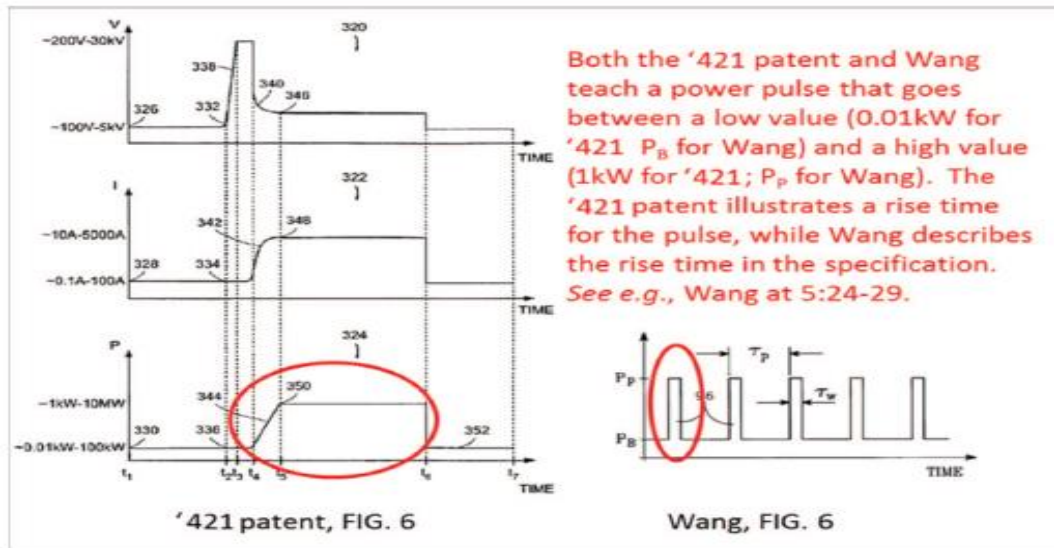

As can be seen in the annotated comparison shown above, Figure 6 of Wang illustrates that same approach as described in the '421 patent. Ex. 1027 ¶¶ 53–55; Ex. 1001, 15:56–58, 16:32–53, Fig. 6. More specifically, the “periodic pulses applied to the plasma” shown in Figure 6 of the '421 patent, are described as being supplied by the pulsed power supply 234, where the “pulsed power supply 234 continues to supply a background power that is sufficient to maintain the plasma after time t_6 . . . , while the pulsed power supply 234 prepares to deliver the next high-power pulse.” Ex. 1001, 15:37–16:51. We, thus, are persuaded that the periodic pulse waveform described in Wang is sufficient to disclose the claimed “voltage pulse . . . that creates a weakly-ionized plasma and then a strongly-ionized plasma from the weakly-ionized plasma.”

Given the evidence before us in the entire record, for the reasons discussed above, we determine that Petitioner has demonstrated, by a preponderance of evidence, that Wang discloses a “power supply that generates a voltage pulse between the anode and the cathode assembly that creates a weakly-ionized plasma and then a strongly-ionized plasma from the weakly-ionized plasma.”

“creates a weakly-ionized plasma and then a strongly-ionized plasma from the weakly-ionized plasma without an occurrence of arcing between the anode and the cathode assembly”

Petitioner asserts that Wang discloses “forming the strongly-ionized plasma . . . without arcing,” as required by the claims. Pet. 36–37. Figure 6 of Wang is reproduced below (annotations by Petitioner, Pet. 11):

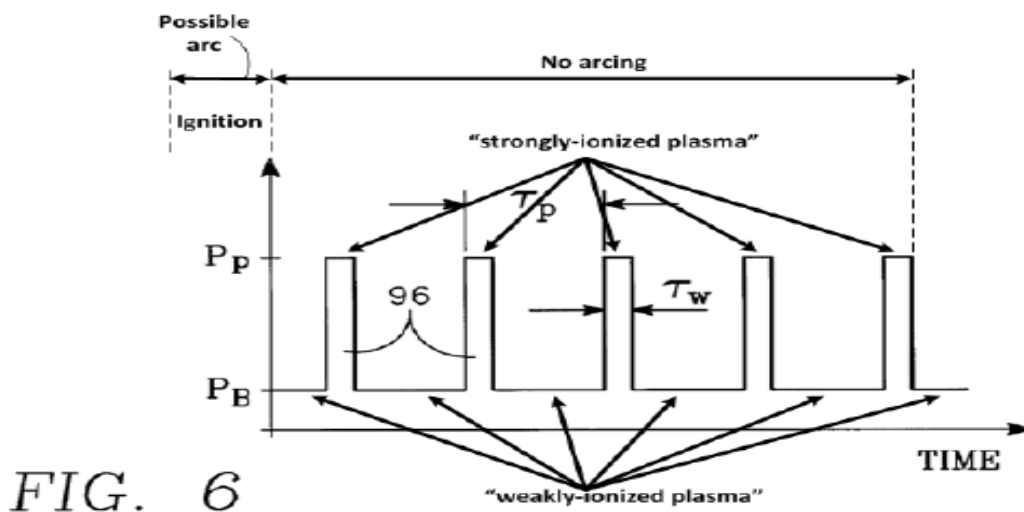

As shown in annotated Figure 6, the target is maintained at background power level P_B between power pulses 96, rising to peak power level P_P . Ex. 1004, 7:13–25. Background level P_B is chosen to exceed the minimum power necessary to support a plasma with little, if any, actual sputter

deposition. *Id.* The initial plasma ignition needs to be performed only once, and at a very low power level so that particulates produced by arcing are much reduced. *Id.* at 7:26–55. According to Dr. Kortshagen, because “the plasma need not be reignited thereafter, arcing will not occur during subsequent applications of the background and peak power levels, P_B and P_P .” Pet. 37; Ex. 1002 ¶ 103; *see also* Ex. 1004, 7:25–28 (“As a result, once the plasma has been ignited at the beginning of sputtering prior to the illustrated waveform [Fig. 6], no more plasma ignition occurs.”).

In its Response, Patent Owner argues that Wang does not disclose eliminating arcing. PO Resp. 33–34. In this regard, Patent Owner draws a distinction between *reducing* electrical breakdown conditions and *eliminating* electrical breakdown conditions. *Id.* For example, Patent Owner argues that “[w]hile the presence of a pre-ionized plasma in figure 6 [of Wang] reduces the likelihood of arcing, Wang never says that the background power P_B entirely eliminated arcing after ignition.” *Id.* at 33 (citing Ex. 1004, 7:47–49; Ex. 2014, 155:24–156:5).

Based on the evidence before us, we are not persuaded by Patent Owner’s arguments. As noted in our claim construction above, we do not construe the claims to require a guarantee of eliminating *all possibility* of an electrical breakdown condition or arcing. Wang discloses that the on-and-off pulsing in the first embodiment (shown in Figure 4), where arcing admittedly occurs, can be improved further by maintaining a background power level P_B between pulses to avoid arcing, as illustrated by Wang’s second embodiment in Figure 6. *See* Ex. 1004, 7:1–8:14. Notably, Wang

recognizes that, in the first embodiment (shown in Figure 4), because the plasma is ignited with a high power pulse in each pulse cycle, the chamber impedance dramatically changes between the on-and-off phases, and large particles are dislodged from the target or chamber. *Id.* at 5:28–32, 7:1–13. By contrast, in Wang’s second embodiment (as shown in Figure 6), the plasma is ignited only once at a much lower power level P_B , the “chamber impedance changes relatively little between the two power levels P_B , P_P ,” (e.g., during the pulse). *Id.* at 7:47–55.

Further still, the power supply operation parameters disclosed in Wang, fall within the broad ranges disclosed in the ’421 patent. *See* Ex. 1027 ¶¶ 38–40; *compare* Ex. 1001, 15:37–17:17, Fig. 6, *with* Ex. 1004, 7:13–25, 5:66–67, Fig. 6. We, thus, are persuaded that one of ordinary skill in the art would have recognized the embodiment illustrated in Figure 6 of Wang discloses “forming the strongly-ionized plasma . . . without arcing,” as required by the claims.

Given the evidence before us in the entire record, we determine that Petitioner has demonstrated, by a preponderance of evidence, that Wang discloses “creat[ing] . . . a strongly-ionized plasma from the weakly-ionized plasma without an occurrence of arcing between the anode and the cathode assembly,” as claimed.

“an amplitude, a duration and a rise time of the voltage pulse being chosen to increase a density of ions in the strongly-ionized plasma”

Independent claims 1 and 17 each recite “an amplitude, a duration and a rise time of the voltage pulse being chosen to increase a density of ions in

the strongly-ionized plasma.” Ex. 1001, 22:22–24, 23:18–20. Independent claims 34 and 46–48 include similar limitations. As previously discussed, Petitioner asserts that “Wang generates . . . a high density plasma with the peak power P_P .” Pet. 35; *see also* Ex. 1004, 7:29–31 (“[T]he application of the high peak power P_P . . . quickly causes the already existing [weakly-ionized] plasma to spread and increases the density of the plasma.”).

According to Petitioner, “Wang’s voltage pulse changes the power level from the background power, P_B , to the peak power, P_P , . . . and each of those peak pulses increases the density of the plasma such that a strongly-ionized plasma is formed. Moreover, the density of Wang’s strongly-ionized plasma increases during application of the peak power, P_P .” Pet. 37–38 (citing Ex. 1004, 7:28–30; Ex. 1002 ¶ 104). Petitioner continues, “Wang therefore generates a ‘voltage pulse’ that increases the ‘density of ions.’ Wang’s voltage pulse has an amplitude, a duration, and a rise time.” *Id.* at 38 (citing Ex. 1002 ¶ 105). Petitioner asserts that “[o]ne of ordinary skill would have understood that Wang’s voltage amplitude and duration was controlled to produce Wang’s specified peak power level P_P .” *Id.* (citing Ex. 1002 ¶ 105).

Patent Owner asserts that Petitioner’s arguments are conclusory and not supported by Wang. PO Resp. 38. Patent Owner supports this assertion, stating merely because an applied electrical pulse has an associated rise time, duration, and amplitude, as in Wang, does not necessitate that the rise time, duration, or amplitude was somehow *chosen* to achieve the result of the claims. *Id.* at 39–41. Patent Owner’s arguments are not persuasive.

Wang selects pulse characteristics and reactors with the goal of “producing a high fraction of ionized sputtered particles” and increasing the density of the plasma, which “has long been exploited in high-density plasma.” *See* Ex. 1004, 1:7–8, 1:30–37, 7:13–30. We are persuaded that one of ordinary skill in the art would have understood from Wang’s disclosure that the parameters of the rise time, duration, and amplitude of a pulse must be controlled, to achieve the desired result, in this instance, to increase the density of the plasma. *See, e.g.*, Ex. 1002 ¶ 105; Ex. 1027 ¶¶ 59–60.

In addition, claims 1, 17, and 46–48 are apparatus claims and claim 34 is a method claim. With respect to the apparatus claims, we are persuaded that the claim recites an intended use that will not limit the scope of the claim, such that anticipation of the claims is based on whether the elements of that claim are disclosed, not on their intended use. With respect to claim 34, the method does not require an optimization of magnitude or rise time to achieve the strongly-ionized plasma, but simply that the amplitude and the rise time of the voltage pulse achieve an increased density of ions, which Wang discloses, as discussed above.

Based on the evidence before us, we are persuaded that Petitioner has demonstrated, by a preponderance of evidence, that Wang discloses choosing an amplitude, a duration, and a rise time of the voltage pulse, in order to increase a density of ions in the strongly-ionized plasma.

For the reasons discussed, we determine that Petitioner has demonstrated, by a preponderance of evidence, that claims 1, 17, 34, and 46–48 are anticipated by Wang.

Claims 11 and 23

Claims 11 and 23 depend from claims 1 and 17, respectively, and recite “wherein the power supply generates a constant voltage.” Ex. 1001, 22:60–61, 23:46–47. As noted by Petitioner, “[a]pplication of [the train of negative] voltage pulses to Wang’s cathode/target 14 and anode 24 produces Wang’s peak power pulses, P_P , which are constant for the duration of the pulse τ_w .” Pet. 47 (citing Ex. 1002 ¶ 132). Relying on testimony from Dr. Kortshagen, Petitioner further asserts that “[o]ne of ordinary skill would have understood that Wang’s voltage would be constant for at least a portion of the duration of the pulse τ_w so as to produce pulse P_P of constant power.” *Id.* (citing Ex. 1002 ¶ 132).

Patent Owner argues Wang does not disclose a power supply that generates a constant voltage. PO Resp. 45–45. According to Patent Owner, and its expert Dr. Hartsough, because “Wang’s power supply is designed to emit pulses having a constant **power** level, its voltage will vary as needed to obtain the target power. *Id.* (citing Ex. 2015 ¶¶ 113–114).

Upon consideration of the parties’ contentions and supporting evidence, we are not persuaded by Patent Owner’s argument and expert testimony. A side-by-side comparison of annotated versions of Figures 6 and 7 of Wang provided by Dr. Overzet, with an annotated version of Figure 6 of the ’421 patent (Pet. 27, annotations added by Dr. Overzet,

Ex. 1027 ¶ 62), reproduced below, reveals that Wang and the Specification of the '421 patent disclose similar waveforms.

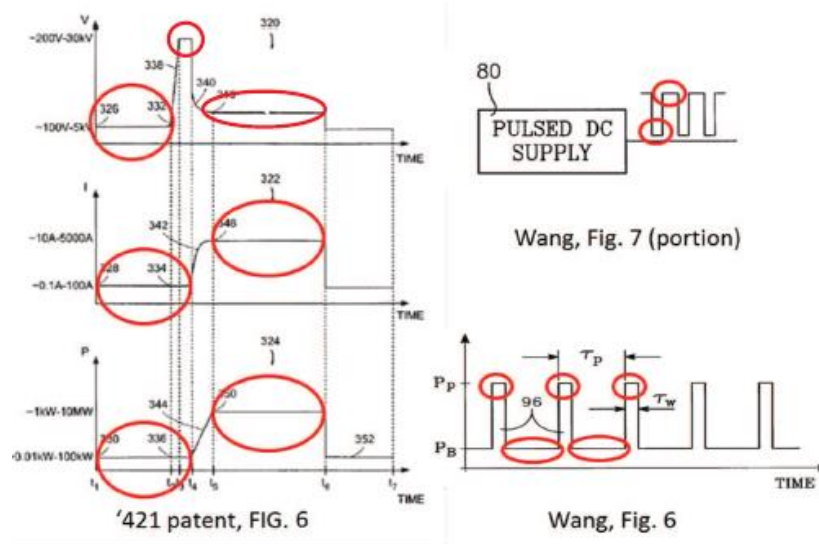

In Figure 6 of the '421 patent, reproduced above, illustrates a “graphical representation of the applied voltage, current, and power as a function of time for periodic pulses applied to the plasma in the plasma generating apparatus” of Figure 4. Ex. 1001, 2:37–40. As shown in Figure 7 of Wang, a portion of which is also reproduced above, pulsed DC power supply 80 produces a series of voltage pulses, and portions of the voltage pulses are constant. Ex. 1004, 7:57–61. Figure 6 of Wang, reproduced above, depicts that portions of the power pulses are constant. Moreover, it is clear from Figures 6 and 7 of Wang that Wang’s system is designed to maintain both the amplitude of the voltage pulses and the amplitude of the power pulses constant during the entire process. Dr. Overzet testifies that “[w]hile Wang’s voltage and power curves will include rise and fall times, there will

also be portions of the pulses in which the voltage and/or power are substantially constant, as illustrated.” Ex. 1027 ¶ 64.

Based on the evidence in this record, we are persuaded that one with ordinary skill in the art would have recognized that Wang discloses that at least portions of the voltage are constant, as required by claims 11 and 23. We, thus, determine that Petitioner has demonstrated, by a preponderance of evidence, that claims 11 and 23 are anticipated by Wang.

Claims 12 and 24

Each of claims 12 and 24, which depend from claims 1 and 17, respectively, recites “wherein a rise time of the voltage pulse is chosen to increase an ionization rate of the strongly-ionized plasma.” Ex. 1001, 22:62–64, 23:48–50. Petitioner asserts that, because the density of the plasma in Wang increases during application of the peak power pulse P_p , the ionization rate of the strongly-ionized plasma also increases. Pet. 47 (citing Ex. 1002 ¶ 133).

In its Response, Patent Owner asserts that Petitioner’s arguments are conclusory and not supported by Wang, and that Wang’s discussion relates only to control of power, rather than control of voltage. PO Resp. 45–48.

In Reply, Petitioner contends that Wang describes “various experimental variables were chosen for the particular purpose of increasing the ionization rate.” Reply 19; *see* Ex. 1027 ¶¶ 66–70. Petitioner further contends that “[a] person of ordinary skill in the art would recognize from the teaching of Wang that the rise time of the voltage pulse is chosen to increase an ionization rate of the strongly-ionized plasma.” Reply 19.

We are persuaded by Petitioner's arguments and evidence. In particular, we agree that Wang discloses selecting pulse characteristics with the goal of "producing a high fraction of ionized sputtered particles." *See* Ex. 1004, 1:7–8; Reply 19. We are persuaded that one of ordinary skill in the art would have understood that the rise time of the voltage pulse in Wang would be controlled to achieve a desired result, e.g., increase the ionization rate of the plasma. Also, as noted above with respect to the "choosing" limitation of claims 1 and 17, the claims recite an intended use that will not limit the scope of the claim, such that anticipation of the claims is based on whether the elements of that claim are disclosed, not on their intended use.

Further, Patent Owner's argument premised on Wang's disclosure that "[w]here chamber impedance is changing, the power pulse width is preferably specified rather than the current or voltage pulse widths" (PO Resp. 47) conflates the two separate embodiments of Wang. In Wang's second embodiment (shown in Figure 6), the "chamber impedance changes relatively little between the two power levels P_B , P_P ," (e.g., during the pulse), and thus, any disclosed preference to specify the power pulse width would not apply. Ex. 1004, 7:47–55.

Based on the evidence in this record, we are persuaded that one with ordinary skill in the art would have recognized that Wang discloses choosing a rise time of the voltage pulse to increase an ionization rate of the strongly-ionized plasma, as required by claims 12 and 24. We, thus, determine that Petitioner has demonstrated, by a preponderance of evidence, that claims 12 and 24 are anticipated by Wang.

Claim 29

Claim 29 depends from claim 17, and recites “wherein a distance from the sputtering target to the substrate support is in the range of approximately 1 cm to 100 cm.” Ex. 1001, 23:63–65. Regarding claim 29, Patent Owner argues that, because Petitioner relies on a portion of Chiang⁹ incorporated by reference into Wang, Petitioner has not made a sufficient showing of anticipation. PO Resp. 49–50. Specifically, Patent Owner argues that Wang does not “clearly identify” the portions of Chiang that is to be incorporated. *Id.* at 50. Patent Owner does not dispute, however, that the claimed distance is disclosed in Chiang.

In its Reply (Reply 20–22), Petitioner points to the portion of Wang incorporating Chiang by reference, in particular, Wang introduces Chiang explaining that:

A recently developed technology of self-ionized plasma (SIP) sputtering allows plasma sputtering reactors to be only slightly modified but to nonetheless achieve efficient filling of metals into high aspect-ratio holes in a low-pressure, low-temperature process. This technology has been described by . . . [another reference and Chiang], both incorporated herein by reference in their entireties.

Ex. 1004, 1:42–51. Wang later specifically indicates that Chiang is relied upon to describe the details of the self-ionized plasma reactor of Figure 1 of Wang. *Id.* at 3:60–61 (introducing the reactor of Figure 1, and stating “[m]ost parts of this reactor have already been described by Chiang et al. in

⁹ U.S. Patent No. 6,398,929 B1, issued June 4, 2002 (Ex. 1009).

the previously cited patent application.”). The portion of Chiang relied upon by Petitioner in its challenge of claim 29 is a portion of this description of the self-ionized plasma reactor. *See* Pet. 48–49 (citing Ex. 1009, 12:66–13:7). Similar to the discussion of incorporation by reference in *Callaway Golf Co. v. Acushnet Co.*, Wang identifies with specificity both what is being incorporated by reference (details of a self-ionized plasma reactor) and where it may be found (Chiang). *Callaway Golf*, F.3d 1311, 1346–47 (Fed. Cir. 2009). We are not persuaded by Patent Owner’s arguments that this incorporation is improper for purposes of the anticipation challenge to claim 29.

Based on the evidence before us, we are persuaded that Petitioner has demonstrated, by a preponderance of evidence, that Wang anticipates claim 29.

Claims 2, 8, 10, 13, 16, 22, 25, 28, 30, 33, 39, 42, and 43

Beyond the arguments provided with respect to the independent claims, which we do not find persuasive for the reasons discussed above, Patent Owner does not provide separate arguments with respect to claims 2, 8, 10, 13, 16, 22, 25, 28, 30, 33, 39, 42, and 43. We have reviewed Petitioner’s arguments and evidence regarding these claims (Pet. 45–46, 48–50; Ex. 1002 ¶¶ 127–128, 130–131, 134–135, 139, 141; Ex. 1004, 1:5–7, 2:33–36, 3:63–66, 4:23–27, 4:32–34, 5:43–49, Figs. 1, 6, 7), and, given the evidence in the record before us, we determine that Petitioner has demonstrated, by a preponderance of evidence, that each of claims 2, 8, 10, 13, 16, 22, 25, 28, 30, 33, 39, 42, and 42 is anticipated by Wang.

D. Obviousness Over Wang and Mozgrin

Petitioner asserts that each of claims 15, 27, and 38 is unpatentable under 35 U.S.C. § 103 as obvious over the combination of Wang and Mozgrin. Pet. 56–59. Petitioner explains how each limitation is disclosed in or taught by the cited references, as well as provides an articulated reasoning with rational underpinning to support combining the prior art teachings. *Id.* Petitioner again relies on the Declarations of Dr. Kortshagen (Ex. 1002) and Dr. Overzet (Ex. 1027) to support its Petition and Reply, respectively. Beyond the arguments provided with respect to the independent claims, which we do not find persuasive for the reasons discussed above, Patent Owner does not provide separate arguments or otherwise address these claims in its Response.

Claims 15, 27, and 38 depend from claims 1, 17, and 34, respectively, and each recites an “amplitude of the voltage pulse is in the range of approximately 1V to 25kV.” Ex. 1001, 23:4–6, 23:57–59, 24:37–38. Petitioner relies on Mozgrin as explicitly disclosing the claimed voltage, e.g., a voltage of approximately 500 Volts. Pet. 58 (citing Ex. 1003, 402; Ex. 1002 ¶ 167). According to Petitioner, “[o]ne of ordinary skill would have been motivated to use Mozgrin’s voltages in Wang[, because b]oth Mozgrin and Wang relate[] to pulsed magnetron sputtering systems and one of ordinary skill reading Wang would have looked to Mozgrin to determine details, such as voltage levels, omitted from Wang.” *Id.* (citing Ex. 1002 ¶ 167). Petitioner contends that the “[u]se of Mozgrin’s voltage level in Wang would have been a combination of old elements to yield predictable

results.” *Id.* at 58–59 (citing Ex. 1002 ¶ 167). We are persuaded by Petitioner’s contentions and evidence.

Given the evidence in the record before us, we determine that Petitioner has demonstrated, by a preponderance of evidence, that each of claims 15, 27, and 38 would have been obvious in view of Wang and Mozgrin.

III. CONCLUSION

For the foregoing reasons, we determine that Petitioner has demonstrated, by a preponderance of the evidence, that claims 1, 2, 8, 10–13, 16, 17, 22–25, 28–30, 33, 34, 39, 42, 43, and 46–48 of the ’421 patent are unpatentable under 35 U.S.C. § 102 as anticipated by Wang, and that claims 15, 27, and 38 of the ’421 patent are unpatentable under 35 U.S.C. § 103 as obvious in view of Wang and Mozgrin.

IV. ORDER

Accordingly, it is:

ORDERED that claims 1, 2, 8, 10–13, 15–17, 22–25, 27–30, 33, 34, 38, 39, 42, 43, and 46–48 of U.S. Patent No. 7,811,421 B2 are held *unpatentable*; and

FURTHER ORDERED that, because this is a Final Written Decision, parties to the proceeding seeking judicial review of the decision must comply with the notice and service requirements of 37 C.F.R. § 90.2.

IPR2014-00800
Patent 7,811,421 B2

For PATENT OWNER:

Bruce J. Barker
bbarker@chsblaw.com

Tarek Fahmi
tarek.fahmi@ascendalaw.com

Gregory J. Gonsalves
gonsalves@gonsalveslawfirm.com

For PETITIONERS:

Fujitsu:

David L. McCombs
david.mccombs.ipr@haynesboone.com

David M O'Dell
david.odell.ipr@haynesboone.com

Richard C. Kim
rckim@duanemorris.com

AMD:

Brian M. Berliner
bberliner@omm.com

Ryan K. Yagura
ryagura@omm.com

Xin-Yi Zhou
vzhou@omm.com

Renesas:

John J. Feldhaus
jfeldhaus@foley.com

IPR2014-00800
Patent 7,811,421 B2

Pavan Agarwal
pagarwal@foley.com

Mike Houston
mhouston@foley.com

GlobalFoundries:

David Tennant
dtennant@whitecase.com

Dohm Chankong
dohm.chankong@whitecase.com

Toshiba:

Robinson Vu
Robinson.vu@bakerbotts.com

Gillette:

Michael A. Diener
michael.diener@wilmerhale.com

Larissa B. Park
larissa.park@wilmerhale.com