

NOTE: This disposition is nonprecedential.

**United States Court of Appeals
for the Federal Circuit**

COLE KEPRO INTERNATIONAL, LLC,
Appellant

v.

VSR INDUSTRIES, INC.,
Appellee

2016-2258

Appeal from the United States Patent and Trademark
Office, Patent Trial and Appeal Board in No. IPR2015-
00182.

Decided: June 19, 2017

JOHN S. ARTZ, Dickinson Wright PLLC, Troy, MI, ar-
gued for appellant. Also represented by BRYAN JOSEPH
SCHOMER.

ADAM YOWELL, Brownstein Hyatt Farber Schreck,
LLP, Reno, NV, argued for appellee. Also represented by
STEVEN A. CALOJARO, MICHAEL D. ROUNDS; EVAN M.
ROTHSTEIN, Denver, CO.

Before PROST, *Chief Judge*, LOURIE, and STOLL, *Circuit Judges*.

STOLL, *Circuit Judge*.

VSR Industries, Inc. filed a petition for inter partes review with the Patent Trial and Appeal Board to review the patentability of Cole Kepro International LLC's U.S. Patent No. 6,860,814. The Board instituted an IPR proceeding on a subset of the grounds in the petition and ultimately determined that three instituted grounds collectively rendered claims 1–14 unpatentable as obvious. Cole Kepro appeals from the Board's final written decision. We affirm.

BACKGROUND

I.

The '814 patent discloses a “gaming apparatus for presenting a wager-type game compris[ing] a cabinet and a door connected to the cabinet.” '814 patent, Abstract. The specification describes “two very common types of gaming devices” in the prior art: (1) mechanical type slot machines; and (2) video gaming devices. *Id.* at col. 1 ll. 14–37. Prior art video gaming devices are described as comprising “a cabinet including a cathode ray tube (CRT) for displaying information,” where the “CRT is supported on a shelf in a main portion of the cabinet and viewable through a[n] opening in the door.” *Id.* at col. 1 ll. 27–37.

According to the specification, these gaming devices “are currently manufactured as separate and distinct designs” in that “a manufacturer custom designs one particular device to be configured as a video gaming device, and custom designs another particular device to be a mechanical reel type device.” *Id.* at col. 1 ll. 40–44. The specification explains that “[t]here are a number of problems with these gaming devices as currently designed.” *Id.* at col. 1 ll. 45–46. For example, the “cost of each individual gaming device is high because it has few fea-

tures which are common to any other gaming device.” *Id.* at col. 1 ll. 46–48. Another problem is that “CRT based video gaming devices are very large because they must accommodate the CRT,” which may be 10–20 inches deep. *Id.* at col. 1 ll. 56–59. These devices are also large in overall size, reducing the number of devices that can be accommodated on a casino floor.

The ’814 patent purports to overcome these problems by disclosing a gaming apparatus that “comprises a device which is readily configured to present one of several different games.” *Id.* at col. 2 ll. 19–21. Additionally, the device’s display comprises an LCD screen or other substantially planar or thin display, which is sized to display information through a viewing window in the cabinet door. The specification praises the advantages of this design:

It will now also be appreciated that the configuration of the gaming devices 20,120 of the invention is such that the total size of the device can be reduced substantially as compared to similar devices utilized today.

. . . .

Advantage[]s are also realized by connecting the video display to the door of the gaming device. In particular, because the display is connected to the door, no supports are needed in the cabinet for the display, freeing up substantial space within the cabinet 22 for other components, such as circuitry and the like. Also, when the door is moved to its open position, the display is moved out of the interior of the cabinet, making the interior portion of the cabinet more accessible. The attachment of the display to the door also renders the display more readily accessible for servicing or removal.

Id. at col. 9 ll. 59–62, col. 10 ll. 46–56.

Figures 4 and 5 of the '814 patent, reproduced below, illustrate the gaming apparatus. As shown, the gaming apparatus includes a cabinet 22, with a back 24, sides 26 and 28, a top 30, a bottom 32, and a door 34. The display 190 is preferably a liquid crystal display or other substantially planar or thin display mounted to the door 34 using a support 74.

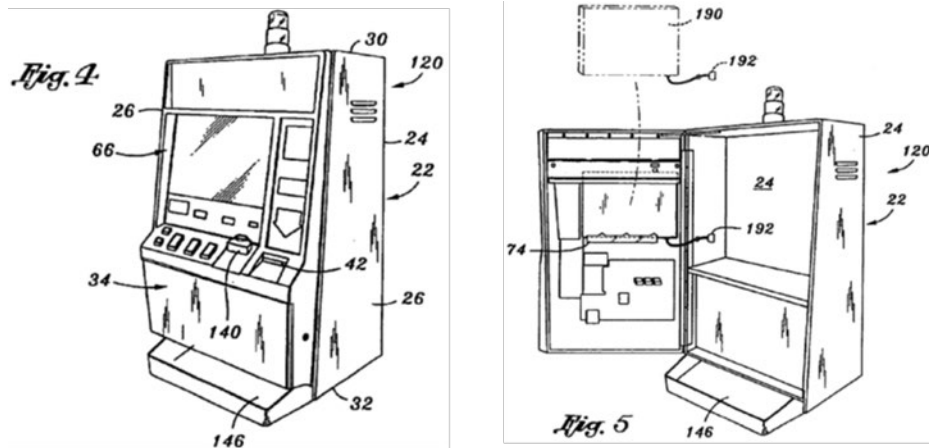

The '814 patent includes claims 1–14. Claims 1 and 8 are independent, claims 2–7 depend from claim 1, and claims 9–14 depend from claim 8. Claim 1 is illustrative of the challenged claims and is reproduced below:

1. A gaming apparatus configured to present one or more wager-based games comprising
 - a cabinet,
 - a door connected to said cabinet,
 - said door moveable between a first position and a second position,
 - said door in said first position cooperating with said cabinet to define a generally closed interior space,

said door in said second position permitting access to said interior space,

said door having an inner surface and an outer surface and an opening therein,

a generally planar video display mounted to said inner surface of said door and movable with said door when said door is moved between said first and second positions,

said video display aligned with said opening in said door to be viewable therethrough,

and at least one gaming controller,

said gaming controller located in said interior space and connected to said video display to provide game information for display by said video display.

Id. at col. 11 ll. 2–17 (line breaks and indentation added for clarity).

II.

VSR petitioned for IPR of the '814 patent, alleging, *inter alia*, that claims 1–14 were unpatentable as obvious under 35 U.S.C. § 103 in view of five different prior art grounds. The Board instituted review of claims 1–14 on the following grounds: (1) obvious in view of U.S. Patent No. 3,796,433 (“Fraley”); (2) obvious in view of Fraley in combination with U.S. Patent No. 4,718,672 (“Okada”); (3) obvious in view of U.S. Patent No. 3,940,136 (“Runte”); (4) obvious in view of Runte in combination with Okada; and (5) obvious in view of U.S. Patent No. 5,351,176 (“Smith”).

The Board’s final written decision concluded that claims 1–8 and 10–14 are unpatentable as obvious in view of Fraley in combination with Okada. J.A. 20–21. The Board additionally concluded that claims 1–14 are un-

patentable as obvious in view of Runte. *Id.* at 29–31. The Board finally concluded that claims 1–8 and 10–14 are unpatentable as obvious in view of Smith. *Id.* at 38–39. The Board also determined that Cole Kepro’s evidence of secondary considerations of nonobviousness did not overcome VSR’s prima facie case of obviousness for any of the grounds of unpatentability.

Cole Kepro timely appealed to this court. We have jurisdiction under 28 U.S.C. § 1295(a)(4)(A) and 35 U.S.C. § 141(c) to review the Board’s final written decision.

DISCUSSION

On appeal, Cole Kepro raises several arguments related to the Board’s obviousness determinations.

A patent claim is unpatentable as obvious “if the differences between the subject matter sought to be patented and the prior art are such that the subject matter as a whole would have been obvious at the time the invention was made to a person having ordinary skill in the art.”¹ 35 U.S.C. § 103. Obviousness under § 103 is a mixed question of law and fact. We review the Board’s ultimate obviousness determination de novo and underlying factual findings for substantial evidence. *Harmonic Inc. v. Avid Tech., Inc.*, 815 F.3d 1356, 1363 (Fed. Cir. 2016). Substantial evidence “means such relevant evidence as a reasonable mind might accept as adequate to support a conclusion.” *Consol. Edison Co. v. NLRB*, 305 U.S. 197, 217 (1938). Factual considerations underlying the obviousness inquiry include the scope and content of the prior art, the differences between the prior

¹ Given the effective filing date of the claims of the ’814 patent, the version of 35 U.S.C. § 103 that applies here is that in force preceding the changes made by the America Invents Act. See Leahy–Smith America Invents Act, Pub. L. No. 112-29, § 3(n), 125 Stat. 284, 293 (2011).

art and the claimed invention, the level of ordinary skill in the art, and relevant secondary considerations. *KSR Int’l Co. v. Teleflex Inc.*, 550 U.S. 398, 406 (2007) (citing *Graham v. John Deere Co.*, 383 U.S. 1, 17–18 (1966)). Relevant secondary considerations include commercial success, long-felt but unmet need, failure of others, and unexpected results. *Id.*

The Board held each claim of the ’814 patent unpatentable as obvious in view of Runte,² which discloses a gaming device, as shown in Figures 1 and 3 below, where the “players sit around a table and manipulate the device.” Runte col. 1 ll. 40–41.

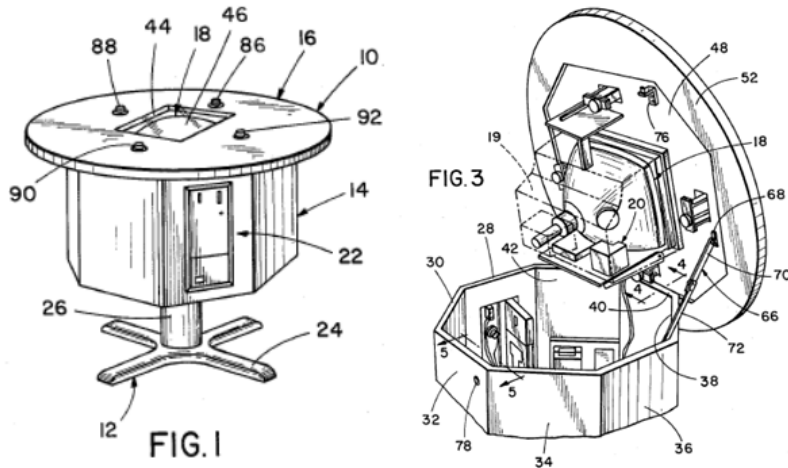

As Runte explains: “Amusement device 10 generally consists of a support 12, a housing 14 mounted on the support 12, a table top 16 hingedly mounted on the housing 14, [and] a conventional cathode ray tube 18 mounted on the interior of table top 16” *Id.* at col. 2 ll. 41–45.

² Because we determine that the Board did not err in concluding that claims 1–14 of the ’814 are unpatentable as obvious in view of Runte, we do not address the other instituted grounds analyzed by the Board.

Runte's table top 16 also has a rectangular screen aperture 44 at its center.

Cole Kepro first argues that the Board's conclusion that it would have been obvious to replace Runte's CRT with an LCD or plasma display, thereby increasing the leg-room for players, is not supported by substantial evidence. Specifically, Cole Kepro argues that Runte "expressly teaches away from any such configuration as its table top device already provides comfortable seating for its patrons." Appellant's Br. 36–37. The Board disagreed, finding that "Runte's disclosure that its device is comfortable does not indicate that user comfort could not be further enhanced by additional legroom." J.A. 28.

"A reference may be said to teach away when a person of ordinary skill, upon reading the reference, would be discouraged from following the path set out in the reference, or would be led in a direction divergent from the path that was taken by the applicant." *Galderma Labs., L.P. v. Tolmar, Inc.*, 737 F.3d 731, 738 (Fed. Cir. 2013) (quoting *DePuy Spine, Inc. v. Medtronic Sofamor Danek, Inc.*, 567 F.3d 1314, 1327 (Fed. Cir. 2009)). Reviewing Runte, we conclude that substantial evidence supports the Board's fact finding that Runte does not teach away from substituting its CRT with an LCD. While Runte does disclose that its table top gaming device already provides comfortable seating for its players, it does not discourage the provision of additional legroom that an LCD or plasma display may provide. Thus, we see no error in the Board's determination that it would have been obvious to a person of ordinary skill in the art to replace Runte's CRT with an LCD or plasma display.

Cole Kepro next argues that substantial evidence does not support the Board's finding that replacing Runte's CRT with an LCD or plasma display would result in a "reduced depth dimension" as required by claim 8. Claim 8 defines a cabinet with a "reduced depth dimension" as

“a cabinet having a first side, a second side, a front and a back, said cabinet having a width from said first side to said second side which exceeds a depth of said cabinet from said front to said back.” ’814 patent col. 11 l. 39 – col. 12 l. 3. The Board construed a similar term in claim 4, “a reduced dimension from said front to said back,” as “encompass[ing] at least a cabinet having a width greater than its depth.” J.A. 7. The parties did not dispute this construction. The Board also construed the term “cabinet” in claim 8 as not requiring an upright orientation. Cole Kepro does not dispute the Board’s claim constructions on appeal.

The Board found that modifying Runte by replacing its CRT with an LCD or plasma display “would result in a ‘reduced depth dimension’ because the flat panel would allow the depth of the housing to be reduced such that its depth is less than its width.” J.A. 28–29. Cole Kepro argues that such modification to Runte would only result in reducing the dimension of the device from top to bottom as opposed to front to back. This argument presumes, however, that the top of Runte’s device, table top 16, cannot also be the front of Runte’s cabinet, housing 14. We disagree.

Claim 8 requires a “door connected to said cabinet, . . . said door in said first position cooperating with said cabinet to enclose at least a portion of said front of said cabinet and define a generally closed interior space.” ’814 patent col. 12 ll. 3–7. While Runte’s device is oriented differently than an upright cabinet, Runte’s table top 16 is a door that is connected to a cabinet, housing 14. Thus, the depth of Runte’s device from top to bottom is oriented in the same direction as the depth of Runte’s cabinet from front to back. In other words, the *front* of Runte’s housing 14 is also the *top* of Runte’s housing 14. Accordingly, we conclude that substantial evidence supports the Board’s interpretation of Runte, and we see no

error in the Board's ultimate conclusion of obviousness as to this claim limitation.

Cole Kepro next argues that the Board erred in holding that dependent claim 9 would have been obvious in view of Runte. Claim 9 depends from claim 8 and adds the further limitation of "a bracket connected to said door support connected to said bracket, said support defining a generally horizontal supporting surface upon which a lower edge of said video display is supported when connected to said door." '814 patent col. 12 ll. 20–23.

In finding that Runte discloses a bracket as recited in claim 9, the Board relied on Cole Kepro's technical expert, Bart Lewin, who testified that "Runte requires equally supporting all four edges of the CRT in order to securely hold the CRT in place and to insure that it remains parallel to the tabletop." J.A. 30 (quoting Lewin Decl., J.A. 427, ¶ 54). Cole Kepro argues on appeal claim 9 required that the only support for the video display must be lower horizontal supporting surface.

As the Board acknowledged, however, "claim 9 does not indicate that the horizontal supporting surface must be the sole source of support for the display. As such, the presence of supports on the other three edges of the display do not preclude the subject matter of claim 9 from being disclosed." J.A. 30–31. We agree that the plain claim language does not support Cole Kepro's interpretation of the claim. Moreover, Cole Kepro does not point to support in the specification for such a construction.

We finally consider Cole Kepro's argument that its licensing evidence overcomes a *prima facie* case of obviousness of claims 1–14 of the '814 patent in view of Runte.

At the PTAB, Cole Kepro submitted nine exemplary licenses to the '814 patent, arguing that the '814 patent had been licensed to the vast majority of the gaming machine market. The Board found that "the large propor-

tion of the relevant industry that has taken a license to the '814 patent weighs in" Cole Kepro's favor. J.A. 46. The Board additionally found, however, that "the significance of the licensing evidence as a secondary consideration of nonobviousness is weakened by several factors." *Id.*

The Board first found that all of the submitted licenses conveyed rights to other patents beyond the '814 patent, demonstrating that the value of the licenses is not entirely attributable to the '814 patent. The Board also found that, of the licenses that provided a royalty rate, most did not separately apportion the royalty rate for the '814 patent, "making a determination of how much of the value of the license is attributable to the '814 patent somewhat speculative." J.A. 46. The Board further found that the per-unit royalty amounts "appear to be quite small compared to the value of the machine," relying on the testimony of Cole Kepro's CEO, Frederick Cook, who testified that one of the license's royalty rates is a "de minimis" amount. J.A. 47. The Board finally found that the lump-sum amount of one of the licenses was "difficult to square with [Cole Kepro's] assertion that the total value of each of the licenses exceeded potential litigation costs." *Id.*

Based on these findings, the Board acknowledged that Cole Kepro's evidence was entitled to some weight, but on balance, determined that this evidence was outweighed by VSR's evidence of obviousness. On appeal, Cole Kepro disagrees, arguing that its licensing evidence supports the nonobviousness of claim 1–14 of the '814 patent.

When presenting licensing evidence to demonstrate commercial success, our cases require affirmative evidence of nexus "because it is often 'cheaper to take licenses than to defend infringement suits.'" *Iron Grip Barbell Co. v. USA Sports, Inc.*, 392 F.3d 1317, 1324 (Fed. Cir. 2004) (quoting *EWP Corp. v. Reliance Universal Inc.*, 755

F.2d 898, 908 (Fed. Cir. 1985)). Accordingly, this evidence must demonstrate that the licensing program was successful because of the merits of the claimed invention as opposed to “business decisions to avoid litigation, [] prior business relationships, or for other economic reasons.” *In re Antor Media Corp.*, 689 F.3d 1282, 1294 (Fed. Cir. 2012).

On this record, we see no error in the Board’s determination that Cole Kepro’s licensing evidence, while entitled to weight, did not overcome VSR’s prima facie case of obviousness. Substantial evidence supports the Board’s findings that: (1) all of the submitted licenses convey rights beyond the ’814 patent; (2) most of these licenses do not separately apportion the royalty rate for the ’814 patent; (3) the per-unit royalty amounts “appear to be quite small compared to the value of the machine”; and (4) the lump-sum amount of at least one of the licenses is “difficult to square with [Cole Kepro’s] assertion that the total value of each of the licenses exceeded potential litigation costs.” J.A. 46–47. Further, while Cole Kepro maintains that “these license agreements were not entered into for the purpose of settling patent infringement litigation,” Appellant Br. 57, this argument is significantly weakened by one of the submitted licenses, which expressly recites the parties’ wishes to resolve an ongoing patent litigation by entering into the licensing agreement.

For these reasons, it is reasonable to understand why the Board found it difficult to ascertain whether these licenses arose out of recognition and acceptance of the claimed subject matter of the ’814 patent or for some other reason unrelated to the merits of the ’814 patent. Accordingly, we see no error in the Board’s fact findings or its conclusion that claims 1–14 of the ’814 would have been obvious in view of Runte.

CONCLUSION

We have considered Cole Kepro's remaining arguments but discern no errors in the Board's analysis. Because we conclude that the Board did not err in holding claims 1–14 of the '814 patent unpatentable, we affirm.

AFFIRMED

COSTS

Costs to Appellee.