



FINNEGAN

Last Month at the Federal Circuit

July 2011

Supreme Court Highlights

Bayh-Dole Act Does Not Automatically Vest Title to Federally Funded Inventions in Federal Contractors

Board of Trustees of the Leland Stanford Junior University v. Roche Molecular Systems, Inc.

No. 09-1159 (U.S. June 6, 2011)

[Appealed from Fed. Cir.]

35 U.S.C. § 282 Requires That an Invalidity Defense Be Proved by Clear and Convincing Evidence, but a Jury May Be Instructed to Evaluate Whether the Evidence Before It Is Materially New

Microsoft Corp. v. i4i Ltd. Partnership

No. 10-290 (U.S. June 9, 2011)

[Appealed from Fed. Cir.]

Stream of Commerce Analysis Does Not Support General Jurisdiction over a Foreign Corporation

Goodyear Dunlop Tires Operations, S.A. v. Brown

No. 10-76 (U.S. June 27, 2011)

[Appealed from N.C. Ct. App.]

No Personal Jurisdiction Exists over a Foreign Party Because Simply Placing Goods in the Stream of Commerce, Without More, Is Not an Act Purposefully Directed to the Forum State

J. McIntyre Machinery, Ltd. v. Nicastro

No. 09-1343 (U.S. June 27, 2011)

[Appealed from N.J. Sup. Ct.]

Federal Circuit Cases

Accused Infringer Need Not Practice Steps Recited in the Preamble of a Method Claim When the Preamble Defines the Environment in Which the

PDF version

Spotlight Info

Looking Ahead

The Read “Enhanced Damages” Standard Must Be Applied Separately from the Seagate “Willful Infringement” Standard

Spectralytics, Inc. v. Cordis Corp.

Nos. 09-1564, 10-1004

(Fed. Cir. June 13, 2011)

[Appealed from D. Minn., Judge Schlitz]

Claim Terms Held Are Not Means-Plus-Function Limitations When Claim Language, in View of Written Description, Recites Sufficiently Definite Structure

Inventio AG v. ThyssenKrupp Elevator

Americas Corp.

No. 10-1525 (Fed. Cir. June 15, 2011)

[Appealed from D. Del., Judge Robreno]

Prior Art Range Encompassing the Claimed Invention Creates a Rebuttable Presumption of Obviousness

Tyco Healthcare Group LP v. Mutual

Pharmaceutical Co.

No. 10-1513 (Fed. Cir. June 22, 2011)

[Appealed from D.N.J., Judge Chesler]

“Competing Patents” Not Sufficient to Confer DJ Jurisdiction

Creative Compounds, LLC v. Starmark Laboratories

No. 10-1445 (Fed. Cir. June 24, 2011)

[Appealed from S.D. Fla., Judge Gold]

Materiality and Intent Are Not a Part of Sliding Scale in Inequitable Conduct

Claim Operates

Advanced Software Design Corp. v. Fiserv, Inc.
Nos. 09-1585, 10-1011 (Fed. Cir. June 2, 2011)
[Appealed from E.D. Mo., Judge Perry]

Nonanalogous Prior Art Cannot Support an Obviousness Rejection

In re Klein
No. 10-1411 (Fed. Cir. June 6, 2011)
[Appealed from Board]

State of the Art Could Not Fill the Gaps in Disclosure for Written Description Support Where the Specifications Indicated Unpredictability and a Lack of Knowledge in the Art

Boston Scientific Corp. v. Johnson & Johnson, Inc.
Nos. 10-1230, -1231, -1233, -1234
(Fed. Cir. June 7, 2011)
[Appealed from D. Del., Judge Robinson]

Analysis

American Calcar, Inc. v. American Honda Motor Co.
Nos. 09-1503, -1567 (Fed. Cir. June 27, 2011)
[Appealed from S.D. Cal., Judge Sabraw]

Abbreviations

ALJ	Administrative Law Judge
ANDA	Abbreviated New Drug Application
APA	Administrative Procedures Act
APJ	Administrative Patent Judge
Board	Board of Patent Appeals and Interferences
Commissioner	Commissioner of Patents and Trademarks
CIP	Continuation-in-Part
DJ	Declaratory Judgment
DOE	Doctrine of Equivalents
FDA	Food and Drug Administration
IDS	Information Disclosure Statement
ITC	International Trade Commission
JMOL	Judgment as a Matter of Law
MPEP	Manual of Patent Examining Procedure
NDA	New Drug Application
PCT	Patent Cooperation Treaty
PTO	United States Patent and Trademark Office
SJ	Summary Judgment
TTAB	Trademark Trial and Appeal Board

DISCLAIMER: The case summaries are intended to convey general information only and should not be construed as a legal opinion or as legal advice. The firm disclaims liability for any errors or omissions and readers should not take any action that relies upon the information contained in this newsletter. You should consult your own lawyer concerning your own situation and any specific legal questions. This promotional newsletter does not establish any form of attorney-client relationship with our firm or with any of our attorneys.

FINNEGAN

Contacts

If you have any questions or need additional information, please contact:

Esther H. Lim, Editor-in-Chief
Joyce Craig, Assistant Editor
Elizabeth D. Ferrill, Assistant Editor
Bart A. Gerstenblith, Assistant Editor

Washington, DC • Atlanta, GA • Cambridge, MA • Palo Alto, CA • Reston, VA • Brussels • Shanghai • Taipei • Tokyo

www.finnegan.com

Copyright © 2011 Finnegan, Henderson, Farabow, Garrett & Dunner, LLP | All rights reserved



FINNEGAN

Last Month at the Federal Circuit

[Back to Main](#)

July 2011

Supreme Court Highlights

Bayh-Dole Act Does Not Automatically Vest Title to Federally Funded Inventions in Federal Contractors

Bart A. Gerstenblith

Chief Justice Roberts delivered the opinion of the Court, in which Justices Scalia, Kennedy, Thomas, Alito, Sotomayor, and Kagan joined. Justice Sotomayor filed a concurring opinion. Justice Breyer filed a dissenting opinion, in which Justice Ginsburg joined.

[Appealed from Fed. Cir.]

In *Board of Trustees of the Leland Stanford Junior University v. Roche Molecular Systems, Inc.*, No. 09-1159 (U.S. June 6, 2011), the Supreme Court held that the University and Small Business Patent Procedures Act of 1980 (the “Bayh-Dole Act” or “Act”) does not automatically vest title to federally funded inventions in federal contractors or authorize contractors to unilaterally take title to such inventions.

In the 1980s, Cetus, a research company, worked with Dr. Holodniy, a scientist from Stanford, to test the efficacy of new AIDS drugs. Dr. Holodniy signed an agreement with Stanford stating that “he agree[d] to assign” to Stanford his “right, title and interest in” inventions resulting from his employment there. Slip op. at 2 (alteration in original). Later, as a condition to working with Cetus, Dr. Holodniy signed an agreement stating that he “will assign and do[es] hereby assign” to Cetus his “right, title and interest in . . . the ideas, inventions, and improvements” made “as a consequence of [his] access” to Cetus. *Id.* (alterations in original). Working at Cetus, Dr. Holodniy developed a PCR-based procedure for measuring the amount of HIV in a patient’s blood. After returning to Stanford and testing the procedure, Stanford obtained three patents on the measuring process.

Roche Molecular Systems, Inc. (“Roche Molecular Systems”) acquired Cetus’s PCR-related assets. After conducting clinical trials on the HIV quantification method developed at Cetus, Roche Molecular Systems commercialized the procedure and is now used worldwide.

The Supreme Court discussed the Bayh-Dole Act, indicating that it allocates rights in federally funded “subject invention[s]” between the federal government and federal contractors. Because some of Stanford’s research on the HIV measurement technique was funded by the National Institutes of Health (“NIH”), the Act applied. Stanford complied with the provisions of the Act and notified NIH that it was electing to retain title to the invention and granted the government a license to use the patented

procedure.

Stanford filed suit against Roche Molecular Systems, Roche Diagnostics Corporation, and Roche Diagnostics Operations, Inc. (collectively “Roche”), claiming that their HIV test kits infringed Stanford’s patents. Roche asserted several defenses, including that Dr. Holodniy’s agreement with Cetus gave Cetus (and consequently, Roche) co-ownership of the inventions, and thus Stanford lacked standing to sue Roche for patent infringement. In response, Stanford contended that Dr. Holodniy did not have any rights to assign to Cetus because Stanford had superior rights under the Act.

The district court agreed with Stanford and held that under the Act, Dr. Holodniy had no rights to assign to Cetus. The Federal Circuit, however, disagreed, concluding that Dr. Holodniy’s agreement with Cetus assigned his rights to Cetus, and thus to Roche, and that the Act did not automatically void an inventor’s rights in federally funded inventions. Thus, the Act did not extinguish Roche’s ownership interest in the invention, and Stanford lacked standing.

The Supreme Court first noted that the basic idea that inventors have the right to patent their inventions has not changed in the 220 years since the passage of the first Patent Act in 1790. And, that it is also well established that an inventor can assign his rights in an invention to a third party, such as an employer.

Second, Congress has divested inventors of their rights in inventions in several specific contexts by using “unambiguous” language, such as stating that title to such inventions “shall be vested in, and be the property of the [Atomic Energy] Commission,” “shall be the exclusive property of the United States,” and “shall vest in the United States.” *Id.* at 8 (alteration in original). The Court found, however, that “[s]uch language is notably absent from the Bayh-Dole Act. . . . Instead, the Act provides that contractors may ‘elect to retain title to any subject invention.’ . . . A ‘subject invention’ is defined as ‘any invention of the contractor conceived or first actually reduced to practice in the performance of work under a funding agreement.’” *Id.* at 8-9 (quoting 35 U.S.C. §§ 202(a), 201(e)).

Third, the Supreme Court rejected Stanford’s argument that the phrase “invention of the contractor” should be “read to include all inventions made by the contractor’s employees with the aid of federal funding.” *Id.* at 9. According to the Court, Stanford’s interpretation would render “of the contractor” superfluous. Rather, “of the contractor” is naturally read to mean “invention owned by the contractor” or “invention belonging to the contractor” because, as the Court has previously held, “[t]he use of the word ‘of’ denotes ownership.” *Id.* (alteration in original) (citations omitted). While the Court found Stanford’s reading of the phrase “plausible enough in the abstract, . . . patent law has always . . . rejected the idea that mere employment is sufficient to vest title to an employee’s invention in the employer.” *Id.* at 10.

Fourth, the Court read § 202(a) of the Act, stating that contractors may “elect to *retain* title,” as confirming that the Act does not “*vest* title.” *Id.* at 11. It noted that Stanford argues the opposite conclusion only because it reads “retain” to mean “acquire” and “receive.” *Id.* But, according to the Court, “retain” means “to hold or continue to hold in possession or use.” *Id.* In other words, “[y]ou cannot retain something unless you already have it.” *Id.*

Additionally, the Court also found that the provisions pertaining to inventors’ rights in subject inventions were consistent with the Court’s interpretation of the Act. The Act provides that “a federal agency may ‘grant requests for *retention* of rights by the inventor . . . [i]f a contractor does not elect to retain title to a subject invention.’” *Id.* at 12 (alterations in original) (emphasis added) (quoting 35 U.S.C. § 202(d)).

Thus, “[b]y using the word ‘retention,’ [the Act] assumes that the inventor had rights in the subject invention at some point, undermining the notion that the Act automatically vests title to federally funded inventions in federal contractors.” *Id.*

Finally, the Supreme Court found that the limited scope of the Act’s procedural protections for third parties and inventors “bolsters” the Court’s conclusion that “there is no need to protect inventor or third-party rights, because the only rights at issue are those of the contractor and the Government.” *Id.* at 13. Thus, the Court found that “[i]t would be noteworthy enough for Congress to supplant one of the fundamental precepts of patent law and deprive inventors of rights in their own inventions. To do so under such unusual terms would be truly surprising.” *Id.* at 14.

Accordingly, the Court concluded that the “Act does not confer title to federally funded inventions on contractors or authorize contractors to unilaterally take title to those inventions; it simply assures contractors that they may keep title to whatever it is they already have.” *Id.* at 11. Thus, the Supreme Court affirmed the Federal Circuit’s decision.

In a concurring opinion, Justice Sotomayor wrote separately to note that she shares the dissent’s concerns regarding the principles adopted by the Federal Circuit in *FilmTec Corp. v. Allied-Signal, Inc.*, 939 F.2d 1568 (Fed. Cir. 1991), and the application of those principles to agreements that implicate the Bayh-Dole Act. Because Stanford failed to challenge the Federal Circuit’s decision on those grounds, however, she agreed that the appropriate disposition is to affirm. She also agreed with the dissent that the majority opinion leaves the door open for the Court to consider arguments related to *FilmTec* in a future case.

In a dissenting opinion, Justice Breyer reframed the issue on appeal as “[w]hether a federal contractor university’s statutory right under the Bayh-Dole Act, 35 U. S. C. §§200–212, in inventions arising from federally funded research can be terminated unilaterally by an individual inventor through a separate agreement purporting to assign the inventor’s rights to a third party.” Breyer Dissent at 1 (citation omitted). In the dissent’s view, the answer to this question was “likely no,” but because the issue was not fully briefed, the dissent would return the case to the Federal Circuit for further argument.

The dissent agreed with the majority that the Bayh-Dole Act does not “simply take the individual inventors’ rights and grant them to the Government.” *Id.* at 4. Rather, the Act “assumes that the federal funds’ recipient, say a university or small business, will possess those rights.” *Id.* The dissent presented two “different legal routes” to what it considered “an interpretation more consistent with the statute’s objectives.” *Id.* at 6. The first route would disagree with the Federal Circuit’s decision in *FilmTec*, find that Stanford and Cetus had competing equitable interests in the inventions, and that Stanford’s equitable claims were stronger than Cetus’s because Stanford’s contract with Dr. Holodniy came first and Stanford subsequently obtained a postinvention assignment. The second route proposed by the dissent would treat the Bayh-Dole Act “as ordinarily assuming, and thereby ordinarily requiring, an assignment of patent rights by the federally funded employee to the federally funded employer.” *Id.* at 8. Although conceding that this latter route “would treat federally funded employees of contractors (subject to the Act) differently than the law ordinarily treats private sector employees,” the dissent argued that there was sufficient precedent to support that interpretation. *Id.*

Ultimately, the dissent’s views were only “tentative,” with the preferred route to remand “to provide the parties with an opportunity to argue these, or related, matters more fully.” *Id.* at 10.

FINNEGAN

If you have any questions or need additional information, please contact:

[Esther H. Lim](#), Editor-in-Chief

[Joyce Craig](#), Assistant Editor

[Elizabeth D. Ferrill](#), Assistant Editor

[Bart A. Gerstenblith](#), Assistant Editor

Washington, DC • Atlanta, GA • Cambridge, MA • Palo Alto, CA • Reston, VA • Brussels • Shanghai • Taipei • Tokyo

www.finnegan.com

Copyright © 2011 Finnegan, Henderson, Farabow, Garrett & Dunner, LLP | All rights reserved



FINNEGAN

Last Month at the Federal Circuit

[Back to Main](#)

July 2011

Supreme Court Highlights

35 U.S.C. § 282 Requires That an Invalidity Defense Be Proved by Clear and Convincing Evidence, but a Jury May Be Instructed to Evaluate Whether the Evidence Before It Is Materially New

Bart A. Gerstenblith

Justice Sotomayor delivered the opinion of the Court, in which Justices Scalia, Kennedy, Ginsburg, Breyer, Alito, and Kagan joined. Justice Breyer filed a concurring opinion, in which Justices Scalia and Alito joined. Justice Thomas filed an opinion concurring in the judgment. Chief Justice Roberts took no part in the consideration or decision of the case.

[Appealed from Fed. Cir.]

In *Microsoft Corp. v. i4i Ltd. Partnership*, No. 10-290 (U.S. June 9, 2011), the Supreme Court held that 35 U.S.C. § 282 requires that an invalidity defense be proved by clear and convincing evidence. In so doing, the Court rejected Microsoft Corp.'s ("Microsoft") contention that the jury may be instructed that a patent invalidity defense need only be proved by a preponderance of the evidence under certain circumstances, namely, when prior art evidence relied upon for a patent invalidity defense was not before the PTO during examination.

i4i Limited Partnership and Infrastructures for Information Inc. (collectively "i4i") hold the patent-at-issue in this case, which claims an improved method for editing computer documents. In 2007, i4i sued Microsoft for willful infringement. Microsoft counterclaimed and sought a declaration that i4i's patent was invalid and unenforceable.

In the district court, Microsoft objected to i4i's proposed jury instruction that it was required to prove its invalidity defense by clear and convincing evidence, and proposed an instruction that described its burden as a preponderance of the evidence for prior art that the examiner did not review during prosecution of the patent-in-suit. The district court rejected Microsoft's proposed language and instructed the jury that the burden was clear and convincing evidence. The Federal Circuit affirmed, relying on its settled interpretation of § 282.

The Supreme Court first pointed to Congress's use of the phrase "presumed valid" when describing a patent in § 282, finding that such use codified the common law presumption of patent validity in effect prior to the Patent Act of 1952 (the "Act") and, implicitly, the heightened standard of proof attached to it. The Court found that the heightened standard applies whether or not the prior art evidence was before

the PTO during examination, and noted that even the pre-Act case law did not adopt or endorse a fluctuating standard of proof advanced by Microsoft. Further, many of the Supreme Court's pre-Act decisions applied the heightened standard of proof without discussing whether the relevant prior art was before the PTO during examination.

The Supreme Court explained how the issue of whether invalidity evidence was before the PTO could be incorporated in jury instructions:

Simply put, if the PTO did not have all material facts before it, its considered judgment may lose significant force. And, concomitantly, the challenger's burden to persuade the jury of its invalidity defense by clear and convincing evidence may be easier to sustain. In this respect, although we have no occasion to endorse any particular formulation, we note that a jury instruction on the effect of new evidence can, and when requested, most often should be given. When warranted, the jury may be instructed to consider that it has heard evidence that the PTO had no opportunity to evaluate before granting the patent. When it is disputed whether the evidence presented to the jury differs from that evaluated by the PTO, the jury may be instructed to consider that question. In either case, the jury may be instructed to evaluate whether the evidence before it is materially new, and if so, to consider that fact when determining whether an invalidity defense has been proved by clear and convincing evidence.

Slip op. at 17-18 (citation omitted).

Finally, the Supreme Court declined the parties' invitations to judge their policy arguments. Instead, the Court deferred to Congress, noting that "Congress specified the applicable standard of proof in 1952 when it codified the common-law presumption of patent validity. Since then, it has allowed the Federal Circuit's correct interpretation of § 282 to stand. Any re-calibration of the standard of proof remains in its hands." *Id.* at 20.

Accordingly, the Supreme Court affirmed the Federal Circuit's decision.

In a concurring opinion, Justice Breyer wrote separately to emphasize that "the evidentiary standard of proof applies to questions of fact and not to questions of law." Breyer Concurrence at 1. Thus, the standard is applicable where the dispute is about, e.g., "when a product was first sold or whether a prior art reference had been published." *Id.* But, Justice Breyer expressed his view that "[m]any claims of invalidity rest, however, not upon factual disputes, but upon how the law applies to facts as given." *Id.* For example:

Do the given facts show that the product was previously "in public use"? 35 U. S. C. §102(b). Do they show that the invention was "novel[]" and that it was "nonobvious"? §§102, 103. Do they show that the patent applicant described his claims properly? §112. Where the ultimate question of patent validity turns on the correct answer to legal questions—what these subsidiary legal standards mean or how they apply to the facts as given—today's strict standard of proof has no application.

Id. (alteration in original).

To help compartmentalize the clear and convincing standard within its proper "fact-related" bounds,

Justice Breyer recommended using case-specific jury instructions or “using interrogatories and special verdicts to make clear which specific factual findings underlie the jury’s conclusions.” *Id.* at 2. Thus, in Justice Breyer’s view, “courts can increase the likelihood that discoveries or inventions will not receive legal protection where none is due.” *Id.*

Justice Thomas concurred in the Court’s judgment, but wrote separately because he was “not persuaded that Congress codified a standard of proof when it stated in the Patent Act of 1952 that [a] patent shall be presumed valid” or that the words “so clearly conveyed a particular standard of proof to the judicial mind in 1952 as to constitute a term of art.” Thomas Concurrence at 1 (alteration in original). Justice Thomas, however, reached the same outcome as the majority because § 282’s silence as to the standard of proof reflected that “it did not alter the common-law rule.” *Id.* at 2.

FINNEGAN

If you have any questions or need additional information, please contact:

[Esther H. Lim](#), Editor-in-Chief

[Joyce Craig](#), Assistant Editor

[Elizabeth D. Ferrill](#), Assistant Editor

[Bart A. Gerstenblith](#), Assistant Editor

Washington, DC • Atlanta, GA • Cambridge, MA • Palo Alto, CA • Reston, VA • Brussels • Shanghai • Taipei • Tokyo

www.finnegan.com

Copyright © 2011 Finnegan, Henderson, Farabow, Garrett & Dunner, LLP | All rights reserved



FINNEGAN

Last Month at the Federal Circuit

[Back to Main](#)

July 2011

Supreme Court Highlights

Stream of Commerce Analysis Does Not Support General Jurisdiction over a Foreign Corporation

Esther H. Lim

Justice Ginsburg delivered the opinion for a unanimous Court.

[Appealed from N.C. Ct. App.]

In *Goodyear Dunlop Tires Operations, S.A. v. Brown*, No. 10-76 (U.S. June 27, 2011), the Supreme Court reversed the judgment of the North Carolina Court of Appeals that general jurisdiction existed over foreign corporations whose tires reached the State through the stream of commerce. The Court's decision addressed the question of whether "foreign subsidiaries of a United States parent corporation [are] amenable to suit in state court on claims unrelated to any activity of the subsidiaries in the forum State." Slip op. at 1.

North Carolina residents whose sons died in a bus accident outside Paris, France, filed a wrongful-death suit in North Carolina state court, claiming that the accident was caused by a defective tire manufactured in Turkey at a foreign subsidiary of The Goodyear Tire and Rubber Company ("Goodyear USA"). The suit named Goodyear USA, an Ohio corporation with plants in North Carolina, and three of its subsidiaries, organized and operating in Turkey, Luxembourg, and France, respectively (collectively "Petitioners"). Unlike Goodyear USA, its foreign subsidiaries contested jurisdiction. The trial court denied Petitioners' motion to dismiss and the North Carolina Court of Appeals affirmed, concluding that general jurisdiction existed over Petitioners. The Supreme Court granted certiorari.

As the Supreme Court held in the landmark decision *International Shoe Co. v. Washington*, 326 U.S. 310, 316 (1945), jurisdiction over an out-of-state defendant must comply with "traditional notions of fair play and substantial justice." Cases following *International Shoe* "have differentiated between general or all-purpose jurisdiction, and specific or case-linked jurisdiction." Slip op. at 2. General jurisdiction over a foreign corporation exists when the contacts with the forum State are "so 'continuous and systematic' as to render them essentially at home in the forum State." *Id.* Leading indicators triggering general jurisdiction are defendant's domicile, place of incorporation, and principal place of business. Specific jurisdiction, however, is based on the connection between the forum State and the underlying controversy where the defendant purposefully avails itself of the privilege of conducting activities within the forum. Thus, specific jurisdiction is "confined to adjudication of 'issues deriving from, or connected with, the very

controversy that establishes jurisdiction.” *Id.* (citation omitted).

Here, because the bus tire involved in the accident was manufactured and sold abroad, North Carolina courts lacked specific jurisdiction. In considering whether general jurisdiction exists over Petitioners, however, the North Carolina courts conflated general and specific jurisdictional inquiries. The North Carolina courts incorrectly concluded that some of the tires made abroad that reached North Carolina through the stream of commerce gave rise to general jurisdiction over the foreign corporations. “A connection so limited between the forum and the foreign corporation . . . is an inadequate basis for the exercise of general jurisdiction.” *Id.* at 3.

That is particularly true where, as here, the connections between Petitioners and North Carolina are so tenuous. Petitioners manufacture tires primarily for sale in European and Asian markets, and the tires differ in size and construction from those sold in the United States. Petitioners are not registered to do business in or have any place of business, employees, or bank accounts in North Carolina. Petitioners do not solicit business in North Carolina or themselves sell or ship tires to customers in North Carolina. A small percentage of Petitioners’ tires are distributed in North Carolina by other Goodyear USA affiliates. These facts, in the Court’s view, did not rise to the “continuous and systematic contacts” with the forum necessary for general jurisdiction. Accordingly, the Court reversed the judgment of the North Carolina Court of Appeals.

The logo for the law firm Finnegan, Henderson, Farabow, Garrett & Dunner, LLP. The word "FINNEGAN" is written in a bold, green, sans-serif font.

If you have any questions or need additional information, please contact:

[Esther H. Lim](#), Editor-in-Chief

[Joyce Craig](#), Assistant Editor

[Elizabeth D. Ferrill](#), Assistant Editor

[Bart A. Gerstenblith](#), Assistant Editor

Washington, DC • Atlanta, GA • Cambridge, MA • Palo Alto, CA • Reston, VA • Brussels • Shanghai • Taipei • Tokyo

www.finnegan.com

Copyright © 2011 Finnegan, Henderson, Farabow, Garrett & Dunner, LLP | All rights reserved



FINNEGAN

Last Month at the Federal Circuit

[Back to Main](#)

July 2011

Supreme Court Highlights

No Personal Jurisdiction Exists over a Foreign Party Because Simply Placing Goods in the Stream of Commerce, Without More, Is Not an Act Purposefully Directed to the Forum State

Esther H. Lim

Justice Kennedy delivered the opinion of the Court, in which Chief Justice Roberts and Justices Scalia and Thomas joined. Justice Breyer filed an opinion concurring in the judgment, in which Justice Alito joined. Justice Ginsburg filed a dissenting opinion, in which Justices Sotomayor and Kagan joined.

[Appealed from N.J. Sup. Ct.]

In *J. McIntyre Machinery, Ltd. v. Nicastro*, No. 09-1343 (U.S. June 27, 2011), the Supreme Court reversed the judgment of the New Jersey Supreme Court that New Jersey state courts can exercise jurisdiction over a foreign manufacturer without contravening the Fourteenth Amendment's Due Process Clause. In so doing, the Court addressed the decades-old question of "[w]hether a person or entity is subject to the jurisdiction of a state court despite not having been present in the State either at the time of suit or at the time of the alleged injury, and despite not having consented to the exercise of jurisdiction." Slip op. at 1.

Robert Nicastro injured his hand in New Jersey while using a metal-shearing machine manufactured by petitioner J. McIntyre Machinery, Ltd. ("J. McIntyre"). The machine was made in England, where J. McIntyre is incorporated and operates. J. McIntyre at no time marketed goods in New Jersey or shipped them there; instead, J. McIntyre sold its goods to a U.S. distributor, who in turn sold the machines in the United States. Although J. McIntyre's officials attended trade shows in the United States, none were in New Jersey. No more than four J. McIntyre machines (the record suggested only one), including the one that allegedly caused Nicastro's injuries, ended up in New Jersey.

Nicastro sued J. McIntyre in New Jersey state court, and J. McIntyre sought to dismiss the suit for lack of personal jurisdiction. The New Jersey Supreme Court held that the state court can exercise jurisdiction over a foreign manufacturer so long as it knew or reasonably should have known that its products are distributed through a nationwide distribution system that might lead to sales in any of the fifty states, and failed to take any reasonable steps to prevent the distribution of its products in the forum State. The Supreme Court granted certiorari.

Justice Kennedy's plurality opinion, joined by three other Justices, focused on jurisdiction over disputes that "arise out of or are connected with the activities within the state." *Id.* at 6 (citing *Int'l Shoe Co. v. Washington*, 326 U.S. 310, 319 (1945)). In such cases, the principal inquiry is "whether the defendant's activities manifest an intention to submit to the power of a sovereign," i.e., purposeful availment of the benefits and protections of the forum State's laws. *Id.* at 7. Justice Kennedy advocated the explanation provided in Justice O'Connor's concurrence (for four Justices) in *Asahi Metal Industry Co. v. Superior Court of Cal., Solano Cty.*, 480 U.S. 102 (1987), that "[t]he placement of a product into the stream of commerce, without more, is not an act of the defendant purposefully directed toward the forum State." Slip op. at 8. Thus, contrary to the standard stated in Justice Brennan's concurrence (for four Justices) in *Asahi*, which "made foreseeability the touchstone of jurisdiction," *id.* at 7, the Court's precedent supports a standard in which "it is the defendant's actions, not his expectations, that empower a State's courts to subject him to judgment," *id.* at 7-8.

In this case, Justice Kennedy focused on J. McIntyre's "purposeful contacts with New Jersey, not with the United States" as the relevant question. *Id.* at 11. Nicaastro's claim of jurisdiction centered on three facts in support of jurisdiction: (1) a distributor selling J. McIntyre's machines in the United States, (2) J. McIntyre officials attending trade shows in several States but not in New Jersey, and (3) up to four machines ending up in New Jersey. While all are targeted "to serve the U.S. market, . . . they do not show that J. McIntyre purposefully availed itself of the New Jersey market." *Id.* Because "the stream-of-commerce metaphor cannot supersede either the mandate of the Due Process Clause or the limits on judicial authority that Clause ensures," Justice Kennedy reversed the judgment of the New Jersey Supreme Court. *Id.* at 11-12.

Justice Breyer filed a separate opinion concurring in the judgment but not the plurality's reasoning. Justice Breyer acknowledged that to exercise jurisdiction, Justice O'Connor's concurrence in *Asahi* required "'something more' than simply placing 'a product into the stream of commerce,' even if defendant is 'awar[e]' that the stream 'may or will sweep the product into the forum State.'" Breyer Concurrence at 3 (alteration in original) (quoting *Asahi*, 480 U.S. at 111, 112). Indeed, he noted that "[n]one of our precedents finds that a single isolated sale, even if accompanied by the kind of sales effort indicated here, is sufficient." *Id.* at 2.

According to Justice Breyer, this case should be decided narrowly to reverse the judgment of the New Jersey Supreme Court because Nicaastro failed to carry his burden of proving jurisdiction and has not shown any specific effort by J. McIntyre to sell in New Jersey. *Id.* at 1-2. However, Justice Breyer declined to "refashion basic jurisdictional rules" because this case was not a suitable vehicle. *Id.* at 4. Instead, he would wait for a future case in which the Solicitor General participates to consider any change to the law in view of "many recent changes in commerce and communication" with "full consideration of the modern-day consequences." *Id.* at 1, 7.

In a dissenting opinion, Justice Ginsburg strongly disagreed with the splintered majority. While agreeing that J. McIntyre is not subject to general jurisdiction, Justice Ginsburg disagreed on whether specific jurisdiction exists based on "affiliatio[n]" between the forum and the underlying controversy." Ginsburg Dissent at 7 (alteration in original) (citation omitted). In her view, J. McIntyre's goal "is simply to sell as much as it can, wherever it can," *id.* at 1, and J. McIntyre likely targeted New Jersey, "the hotbed of scrap-metal businesses," for its three-ton metal-shearing machines, *id.* at 3. In fact, "[t]his case is illustrative of marketing arrangements for sales in the United States common in today's commercial world," where a "foreign-country manufacturer engages a U.S. company to promote and distribute the manufacturer's products." *Id.* at 10.

Justice Ginsburg urged that “[w]hen industrial accidents happen, a long-arm statute in the State where the injury occurs generally permits assertion of jurisdiction.” *Id.* at 11. Here, J. McIntyre purposefully availed itself of the “United States market nationwide, not a market in a single State or a discrete collection of States.” *Id.* at 13. And a fair place of suit within the United States should be a question of venue, not jurisdiction. *Id.* Accordingly, Justice Ginsburg would hold J. McIntyre subject to the jurisdiction of New Jersey courts where the injury occurred. To hold otherwise “would take a giant step away from the ‘notions of fair play and substantial justice’ underlying *International Shoe.*” *Id.* at 19 (citation omitted).

FINNEGAN

If you have any questions or need additional information, please contact:

[Esther H. Lim](#), Editor-in-Chief

[Joyce Craig](#), Assistant Editor

[Elizabeth D. Ferrill](#), Assistant Editor

[Bart A. Gerstenblith](#), Assistant Editor

Washington, DC • Atlanta, GA • Cambridge, MA • Palo Alto, CA • Reston, VA • Brussels • Shanghai • Taipei • Tokyo

www.finnegan.com

Copyright © 2011 Finnegan, Henderson, Farabow, Garrett & Dunner, LLP | All rights reserved

The logo for Finnegan, featuring the word "FINNEGAN" in large, white, serif capital letters. The letters are superimposed over a background of several old, leather-bound books with gold-tooled spines, arranged in a row. The lighting is warm, highlighting the texture of the books and the metallic sheen of the gold tooling.

FINNEGAN

Last Month at the Federal Circuit

[Back to Main](#)

July 2011

Accused Infringer Need Not Practice Steps Recited in the Preamble of a Method Claim When the Preamble Defines the Environment in Which the Claim Operates

Kevin D. Rodkey

Judges: Bryson (author), Dyk, Prost

[Appealed from E.D. Mo., Judge Perry]

In *Advanced Software Design Corp. v. Fiserv, Inc.*, Nos. 09-1585, 10-1011 (Fed. Cir. June 2, 2011), the Federal Circuit reversed-in-part and vacated-in-part the district court's determination of noninfringement, affirmed the district court's denial of Advanced Software Design Corporation's ("Advanced Software") motion to amend the complaint, and dismissed Fiserv, Inc.'s ("Fiserv") cross-appeal on invalidity.

Advanced Software owns three patents related to check-security technology using "key-based" cryptography: U.S. Patent Nos. 6,233,340 ("the '340 patent"); 6,549,624 ("the '624 patent"); and 6,792,110 ("the '110 patent"). Both Advanced Software and Fiserv offer competing products for preventing check fraud and forgery, which generally work by encrypting and printing selected information on a check. When the check is cashed, the products validate the check by decrypting the encrypted information and comparing it to the unencrypted information on the check.

Advanced Software brought suit against Fiserv, alleging infringement of the '340, '624, and '110 patents. First, the district court denied Advanced Software's motion to amend its complaint. After initial discovery, Advanced Software submitted infringement contentions only for the '624 and '110 patents, then later moved to dismiss the infringement claims based on the '624 patent. After cross-motions for SJ on infringement and invalidity of the remaining '110 patent, the district court granted Fiserv's noninfringement motion, finding that Fiserv did not perform the encrypting and printing steps recited in the preambles of the asserted claims, but denied Fiserv's invalidity motion on the ground that Advanced Software had pointed to genuine issues of material fact relating to invalidity. Advanced Software appealed the district court's rulings related to infringement and denial of its motion to amend its complaint, and Fiserv cross-appealed the denial of SJ related to invalidity.

The preamble of claim 1 of the '110 patent recites "[a] process of validating a negotiable financial instrument made by a payor, in which selected information found on the financial instrument which varies for each instantiation of the financial instrument made by the same payor is encrypted in combination with key information not found on the financial instrument to generate a control code which is printed on the financial instrument along with the selected information" Both parties agreed that the preamble

limits the scope of the claim; however, the parties disagreed whether the accused infringer must perform the steps recited in the preamble.

“Fiserv therefore could ‘use’ the method of claim 1 by validating checks even though it does not encrypt and print them. It would infringe the method of claim 1, however, only by validating checks that have been encrypted and printed in accordance with the steps described in the preamble.” Slip op. at 9.

Drawing a parallel between this case and *Uniloc USA, Inc. v. Microsoft Corp.*, 632 F.3d 1292 (Fed. Cir. 2011), the Federal Circuit reaffirmed that the preamble of a method claim may “define[] the environment” of the process. Specifically, the Court held that Fiserv could “use” the method of the asserted claims even though it did not encrypt and print the checks, but Fiserv would infringe the claims only by validating checks that have been encrypted in accordance with the steps described in the preamble. The Court stated that it was “looking to the statement of purpose to distinguish between those limitations that describe the environment in which a claim operates from the limitations that must be performed by an accused infringer.” Slip op. at 11. For this reason, the Court reversed the district court’s finding of noninfringement.

The Court then turned to the district court’s determination that Advanced Software failed to raise its inducement theory of infringement on a timely basis and that Advanced Software failed to provide evidence of Fiserv’s state of mind regarding inducement. The Court determined that Advanced Software offered evidence that Fiserv knew of the ’110 patent, sold its validating software to banks, and instructed customers in how to use the software. Because the Court found that the district court failed to consider this evidence, it vacated the district court’s SJ ruling on inducement.

Next, the Court turned to, and rejected, Fiserv’s four alternative arguments for affirming the district court’s finding of noninfringement. First, the Court rejected Fiserv’s argument that “control code” required a binary string of numbers because the district court construed “control code” as the “end product of the encryption process that is then printed on the check,” which could be encrypted information or cipher text in any form. Second, the Court rejected Fiserv’s argument that its encryption process did not use “key information” in the encrypting step. The Court determined that although the permutation key of Fiserv’s process is applied to selected information before an XOR encryption, the permutation key is still information that is “used with” the overall cryptographic algorithm. For this reason, the Court held that Advanced Software had provided sufficient evidence to prevent SJ for noninfringement. Third, the Court found that Advanced Software had shown a genuine issue of material fact as to whether Fiserv’s encryption algorithm can be widely distributed without compromising security, as required by the claims. Fourth, the Court rejected Fiserv’s argument that its software does not actually validate the checks because it does not provide the functionality necessary to refuse to honor a check. The Court noted, however, that at least one claim refers to “generating a signal in response to the equality” or selected information and decrypted information, and, based on the testimony of a Fiserv employee, there was a genuine issue of material fact as to whether Fiserv satisfies this claim element.

Next, the Court turned to the district court’s construction of the phrase “encrypted in combination with key information” in the preamble of the claims. The Court noted that the district court’s two-step construction of this phrase required (1) selected information from the check to be mathematically combined with the encryption key, and (2) that the combination be encrypted. Although Advanced Software provided a joint claim construction chart seeking the same broad construction of this phrase of the ’110 patent as a

similar phrase in the '624 patent, the Court held that Advanced Software had not agreed that the construction of the two phrases should be the same, even if the district court adopted a narrow construction of the '624 patent and further pointed out that the '624 patent had been dismissed from the suit.

The Court clarified that the “in combination” language is necessary to explain that the selected information and the key are combined through the encryption process; otherwise, the claim would appear to mean that the encryption is performed on the key, not with the encryption algorithm. The Court observed that a key is a necessary input to the encryption algorithm and that keys can change, but the encryption algorithm remains the same. After examining the specification, the Court concluded that the specification supports Advanced Software’s broader construction because it specifically describes an encryption algorithm that combines selected information and keys without describing an initial combining step. The Court then reversed the district court’s construction and held that “selected information . . . encrypted in combination with key information” means that the encryption algorithm combines the selected information and the key to create the control code.

Next, the Court turned to the issue of whether the district court properly denied Advanced Software’s motion to amend the complaint to add a Lanham Act count for false advertising. The Court applied regional circuit law to the district court’s scheduling order and determined that the district court’s interpretation of that order was not inconsistent with the order’s language. The Court applied this interpretation to conclude that Advanced Software must show good cause under Rule 16(b) to amend the complaint. The Court then determined that Advanced Software had not explained what occurred during the four-month period in question before moving to amend, and therefore the Court could not conclude that the district court abused its discretion by failing to consider an important factor, or that the district court committed clear error. For this reason, the Court affirmed the district court’s denial of the motion to amend.

Last, the Court turned to Fiserv’s cross-appeal challenging the district court’s denial of its SJ motion on obviousness and anticipation. The Court held that it lacked jurisdiction to review the cross-appeal because Supreme Court precedent has explained that appellate courts lack jurisdiction over the denial of a motion for SJ based on disputed issues of fact because such a denial does not settle or even tentatively decide anything about the merits of the claim.

The logo for the law firm Finnegan, consisting of the word "FINNEGAN" in a bold, green, sans-serif font.

If you have any questions or need additional information, please contact:

[Esther H. Lim](#), Editor-in-Chief

[Joyce Craig](#), Assistant Editor

[Elizabeth D. Ferrill](#), Assistant Editor

[Bart A. Gerstenblith](#), Assistant Editor

Washington, DC • Atlanta, GA • Cambridge, MA • Palo Alto, CA • Reston, VA • Brussels • Shanghai • Taipei • Tokyo

www.finnegan.com

Copyright © 2011 Finnegan, Henderson, Farabow, Garrett & Dunner, LLP | All rights reserved

FINNEGAN

Last Month at the Federal Circuit

[Back to Main](#)

July 2011

Nonanalogous Prior Art Cannot Support an Obviousness Rejection

Carlos M. Téllez

Judges: Newman, Schall (author), Linn

[Appealed from Board]

In *In re Klein*, No. 10-1411 (Fed. Cir. June 6, 2011), the Federal Circuit reversed the Board's obviousness determination with respect to U.S. Patent Application No. 10/200,747 ("the '747 application") because the Board's finding that five references, upon which the rejections were based, were analogous art was not supported by substantial evidence.

The invention claimed in the '747 application is directed to a mixing device for use in the preparation of sugar-water nectar for certain bird and butterfly feeders. The mixing device comprises a container adapted to receive water and a movable divider. The divider can be positioned at three different locations within the container to define two compartments whose volume depends on the position of the divider. To prepare nectar, one compartment is filled with water and the other with sugar. Once the divider is removed, the sugar and water mix and the solution can be stirred. The three different possible locations for the divider define compartments having specific sugar/water volume ratios to make hummingbird nectar, oriole nectar, or butterfly nectar, respectively. Figure 4 of the '747 application, shown below, illustrates the device (11), the divider (21), and the rail (15) with the compartments filled with water and sugar.

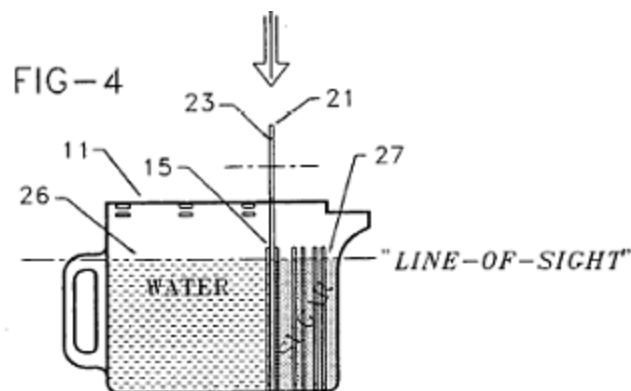

The examiner issued a final office action with five separate rejections under 35 U.S.C. § 103(a), each

rejection supported by a different primary reference in combination with the applicant's admission in the specification that the ratios of sugar to water for the three nectars were known in the art. The five references cited by the examiner were U.S. Patent Nos. 580,899 ("Roberts"); 1,523,136 ("O'Connor"); 2,985,333 ("Kirkman"); 2,787,268 ("Greenspan"); and 3,221,917 ("De Santo"). The Board rejected Mr. Klein's argument that the five cited references were nonanalogous art, finding that each was pertinent to the problem the application addressed, "making a nectar feeder with a movable divider to prepare different ratios of sugar and water for different animals." Slip op. at 5 (citation omitted). Thus, the Board affirmed each of the five obviousness rejections.

On appeal, Mr. Klein argued that the Board failed to make any finding that any of the cited references were "reasonably pertinent" to the problem addressed by his application. In response, the government contended that the Board correctly found that the prior art references were directed toward the same problem, which the government characterized as a "compartment separation problem." *Id.* at 6-7. Thus, the government argued that the problem of keeping things separated was not unique to nectar mixing and storage devices, and that one confronted with the problem would have readily consulted the five references to discover the broad solutions employed therein and applied them to the problem sought to be solved by the '747 application with no more than ordinary skill.

“[A]n inventor considering the problem of ‘making a nectar feeder with a movable divider to prepare different ratios of sugar and water for different animals,’ would not have been motivated to consider either of these references since neither of the references shows a movable divider or the ability to prepare different ratios.” Slip op. at 15-16.

The Federal Circuit considered whether each of the five references was analogous art and thus properly relied upon by the Board in its obviousness determination. The Court reiterated that two separate tests define the scope of analogous prior art: "(1) whether the art is from the same field of endeavor, regardless of the problem addressed and, (2) if the reference is not within the field of the inventor's endeavor, whether the reference still is reasonably pertinent to the particular problem with which the inventor is involved." *Id.* at 7 (quoting *In re Bigio*, 381 F.3d 1320, 1325 (Fed. Cir. 2004)). The Federal Circuit focused solely on whether the references satisfied the "reasonably pertinent to the particular problem" test because that was the only test relied on by the Board. The Court noted that a "reference is reasonably pertinent if, even though it may be in a different field from that of the inventor's endeavor, it is one which, because of the matter with which it deals, logically would have commended itself to an inventor's attention in considering his problem." *Id.* (quoting *In re Clay*, 966 F.2d 656, 659 (Fed. Cir. 1992)). The Federal Circuit first considered the Roberts, O'Connor, and Kirkman references. The Court found that (1) Roberts was directed to an apparatus comprising receptacles designed to receive "statement-cards" and removable partitions that would subdivide the receptacles into compartments; (2) O'Connor was directed to a tool tray having dividers that were readily movable, and that was adapted to contain comparatively small articles, e.g., drills, reamers, bits, etc., or hardware supplies such as bolts or nuts; and (3) Kirkman was directed to a drawer with removable partitions for dividing the drawer into two or more compartments of varying size. Figure 1 from Kirkman (shown below) is generally representative of the type of devices disclosed therein and in Roberts and O'Connor:

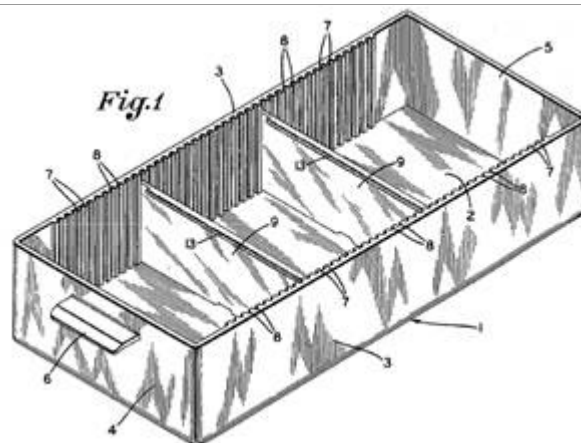

The Federal Circuit agreed with Mr. Klein that each reference is directed to a container designed to *separate* its contents, as opposed to one designed to facilitate the *mixing* of those contents. The Court also agreed that the government could not redefine the problem on appeal as “a compartment separation problem.” *Id.* at 12 n.1. Further, the Court found that none of the three references disclosed a partitioned container that was adapted to receive water or contain it long enough to be able to prepare different ratios in the different compartments. Thus, “[a]n inventor considering the problem of ‘making a nectar feeder with a movable divider to prepare different ratios of sugar and water for different animals’ would not have been motivated to consider any of these references when making his invention.” *Id.* at 12.

The Federal Circuit then considered the Greenspan and De Santo references. The Court found that Greenspan was directed to a blood plasma bottle having compartments for dried plasma and water separated by a wall with a plug, wherein the plug could be removed to allow for mixing. The De Santo reference similarly taught two compartments designed to hold two different types of fluid that could be mixed together by removing a valve in the partition separating the compartments. Thus, each reference was capable of holding a liquid and was directed to “containers that facilitate the mixing of two separated substances together.” *Id.* at 15. The Court concluded, however, that “an inventor considering the problem of ‘making a nectar feeder with a *movable divider to prepare different ratios* of sugar and water for different animals,’ would not have been motivated to consider either of these references since neither of the references shows a movable divider or the ability to prepare different ratios.” *Id.* at 15-16.

Thus, the Federal Circuit reversed the Board’s decision because the Board’s finding that each reference was analogous art was not supported by substantial evidence, and thus none could qualify as prior art under 35 U.S.C. § 103. In light of that finding, the Board’s obviousness rejections could not be sustained and the Court did not need to address Mr. Klein’s arguments regarding long-felt need or the Board’s overall obviousness determination. Accordingly, the Federal Circuit reversed and remanded the decision to the Board for further proceedings consistent with its opinion.

FINNEGAN

If you have any questions or need additional information, please contact:

[Esther H. Lim](#), Editor-in-Chief

[Joyce Craig](#), Assistant Editor

[Elizabeth D. Ferrill](#), Assistant Editor

[Bart A. Gerstenblith](#), Assistant Editor

Washington, DC • Atlanta, GA • Cambridge, MA • Palo Alto, CA • Reston, VA • Brussels • Shanghai • Taipei • Tokyo

www.finnegan.com

Copyright © 2011 Finnegan, Henderson, Farabow, Garrett & Dunner, LLP | All rights reserved



FINNEGAN

Last Month at the Federal Circuit

[Back to Main](#)

July 2011

State of the Art Could Not Fill the Gaps in Disclosure for Written Description Support Where the Specifications Indicated Unpredictability and a Lack of Knowledge in the Art

Jeremy P. Bond

Judges: Bryson, Gajarsa (concurring-in-part), Moore (author)

[Appealed from D. Del., Judge Robinson]

In *Boston Scientific Corp. v. Johnson & Johnson, Inc.*, Nos. 10-1230, -1231, -1233, -1234 (Fed. Cir. June 7, 2011), the Federal Circuit affirmed the district court's grant of SJ that the asserted claims were invalid for lack of written description under 35 U.S.C. § 112, ¶ 1.

Johnson & Johnson, Inc. ("J&J"), and Cordis Corp. ("Cordis") own U.S. Patent Nos. 7,217,286; 7,223,286; and 7,229,473 (collectively "the 1997 patents") and, along with Wyeth, own U.S. Patent No. 7,300,662 ("the '662 patent") (collectively "the patents-in-suit"). The patents-in-suit relate to drug-eluting stents for use in treating coronary artery disease ("CAD"). Bare metal stents, traditionally inserted in an artery to prevent collapse following angioplasty, did not adequately address restenosis (narrowing of the artery) caused by neointimal proliferation (an increase in smooth muscle cells of the artery over time in response to injury caused by angioplasty). Attempts to prevent restenosis led researchers to test numerous oral drugs and drug-eluting stents. Prior to 1997, orally administered rapamycin was known to inhibit restenosis in rats. Several analogs of rapamycin were also known in the art, including everolimus, which is both a macrocyclic lactone and triene analog of rapamycin. Cordis's Cypher® stent, which uses rapamycin as a therapeutic agent, was the first drug-eluting stent approved by the FDA and sold in the United States.

The 1997 patents, which share a common specification, claim drug-eluting stents using either rapamycin or a macrocyclic lactone analog of rapamycin as the therapeutic agent. The 1997 patents contain only a single reference to macrocyclic lactones under the heading "Experiments," but the experiments disclosed therein do not use or provide a single example of a macrocyclic lactone analog. Cordis added the phrase "macrocyclic lactone analog" in a 2006 claim amendment shortly after a competitor, Guidant, received European approval to sell a drug-eluting stent containing everolimus.

The '662 patent was filed in 2004, but J&J, Cordis, and Wyeth (collectively "Appellants") asserted that the claims were entitled to an effective filing date of 2001. The '662 patent claims drug-eluting stents using either rapamycin or a macrocyclic triene analog of rapamycin, but does not provide an example of a

macrocyclic triene analog of rapamycin; rather, the only mention of a similar term in the specification is that “[r]apamycin is a macrocyclic [sic] triene antibiotic.” Slip op. at 8 (alterations in original). The ’662 patent does not include any data on studies performed with any rapamycin analog coated stents. And, as with the 1997 patents, Cordis added the claim language “macrocyclic triene analogs” after Guidant received its European marketing approval.

Appellees Boston Scientific Corporation and Boston Scientific Scimed, Inc. (collectively “BSC”), filed four complaints (later consolidated) against Appellants seeking DJs that the claims of the patents-in-suit are invalid. BSC sells an everolimus-eluting stent system. Appellants counterclaimed for infringement. The parties filed several SJ motions in the district court, including BSC’s SJ motion of invalidity based on nonenablement, lack of adequate written description, and indefiniteness. The district court granted SJ, finding the 1997 patents invalid for nonenablement and lack of adequate written description, and the ’662 patent invalid for lack of adequate written description without addressing enablement.

On appeal, the Federal Circuit agreed that the 1997 patents lacked an adequate written description of the claimed genus of macrocyclic lactone analogs of rapamycin. First, the shared specification contained virtually no information regarding the macrocyclic lactone analogs of rapamycin except that the term was mentioned under the heading “Experiments.” Not one example, however, included a use of a macrocyclic lactone analog. And, the patents gave no guidance on how to properly determine whether a compound was a macrocyclic lactone analog, given the potentially limitless number of compounds that are structurally similar to the complex rapamycin compound. Thus, the Federal Circuit held that “[a]n *ipsis verbis* disclosure of a claimed genus (under the heading Experiments) is not *per se* sufficient to meet the written description requirement.” *Id.* at 18.

“[W]hen the four corners of the specification directly contradict information that the patentee alleges is ‘well-known’ to a person of skill at the effective filing date, no reasonable jury could conclude that the patentee possessed the invention.” Slip op. at 23.

Second, the Court rejected Appellants’ argument that the knowledge in the art was so well known as to excuse a more detailed disclosure in the specification. Although some species were known, Appellants’ own declarations detailed the failure of others to develop drug-eluting stents to inhibit restenosis and the unpredictability of the art. Further, statements in the common specification indicated that the mechanism of action of rapamycin was not fully understood. The Court stated that while a patentee may rely on information that is “well-known in the art” for purposes of meeting the written description requirement, “when the four corners of the specification directly contradict information that the patentee alleges is ‘well-known’ to a person of skill at the effective filing date, no reasonable jury could conclude that the patentee possessed the invention.” *Id.* at 23. Thus, the Court rejected Appellants’ argument that there was a known correlation between the function and structure of rapamycin and its analogs that provided additional written description support for the entire genus of macrocyclic lactone analogs.

Given the absence of information regarding the structural characteristics of macrocyclic lactone analogs or examples of macrocyclic lactone analogs in the specification, and the nascent state of using drug-eluting stents to inhibit restenosis, the Court refused to “reward an inventor’s invitation to other researchers to discover which of the thousands of macrocyclic lactone analogs of rapamycin could conceivably work in a drug-eluting stent.” *Id.* Accordingly, the Court did not separately address whether the 1997 patents were enabled.

Addressing the '662 patent, the Federal Circuit similarly found that the claimed subgenus of "macrocyclic triene analogs" of rapamycin was not adequately described. First, the Court noted that the specification never disclosed the subgenus itself, i.e., the specification never mentioned "macrocyclic triene analogs" of rapamycin; rather, the only disclosure was that "[r]apamycin is a macrocyclic [sic] triene antibiotic." *Id.* at 24 (alterations in original). As in *Fujikawa v. Wattanasin*, 93 F.3d 1559, 1570 (Fed. Cir. 1996), where a claimed subgenus was not disclosed *ipsis verbis* in the specification, the '662 patent failed to indicate that the claimed triene analogs might be of special interest. Thus, the Court found that given the nascent state of using drug-eluting stents at the time of filing, the lack of any "blaze marks" pointing to triene analogs precluded the conclusion that the analogs were adequately described.

Second, the Federal Circuit found that the functional disclosures in the '662 patent failed to sufficiently describe the claimed subgenus of macrocyclic triene analogs or provide sufficient blaze marks as to which analogs might successfully work in drug-eluting stents. Even as of the 2001 effective filing date of the '662 patent, the relationship between the function of rapamycin and its structure was not so well known that it excused the patentee's failure to explicitly disclose the claimed subgenus or any species within the subgenus. Further, as with the 1997 patents, the '662 patent specification confirmed that the mechanism of action of rapamycin was not well known in the art at the effective filing date, thus directly contradicting Appellants' assertion that there was a well-known correlation between the structure of rapamycin and its function.

Finally, the Court noted that the '662 patent contains insufficient support for the highly specific functional requirements claimed. For example, claim 1 required "from about 64 µg to about 197 µg of rapamycin or a macrocyclic triene analog thereof . . . wherein said device provides an in-stent late loss in diameter at 12 months following implantation in a human of less than about 0.5 mm." *Id.* at 27 (alteration in original). The '662 patent, however, failed to include any information suggesting how a person of skill in the art would select macrocyclic triene analogs with such highly specific performance requirements or which structural features of the analogs are necessary to achieve those results.

Accordingly, the Federal Circuit affirmed the district court's grant of SJ that the patents-in-suit were invalid for lack of an adequate written description pursuant to 35 U.S.C. § 112, ¶ 1.

Judge Gajarsa concurred-in-part because, while he agreed that the patents-in-suit were invalid, he would have based that finding for the 1997 patents on nonenablement. According to Judge Gajarsa, the majority's opinion "further extends the written description requirement into the realm of enablement." Gajarsa Concurrence at 2. Specifically, in his view, the 1997 patents did not have to "explain how to synthesize, identify, or determine the biological activity of a suitable macrocyclic lactone analog" because scientists could hypothesize that useful analogs could be created by changing parts of the rapamycin molecule. *Id.* at 3-4. "The patents did, however, need to disclose where the rapamycin molecule should be modified to obtain a suitable analog with the desired efficacy *in stents*." *Id.* at 4. Thus, "[b]ecause no one knew of any rapamycin analogs with the desired efficacy when delivered by stents as of the filing date of the 1997 patents, Appellants' claims are not enabled." *Id.*

FINNEGAN

Joyce Craig, Assistant Editor
Elizabeth D. Ferrill, Assistant Editor
Bart A. Gerstenblith, Assistant Editor

Washington, DC • Atlanta, GA • Cambridge, MA • Palo Alto, CA • Reston, VA • Brussels • Shanghai • Taipei • Tokyo

www.finnegan.com

Copyright © 2011 Finnegan, Henderson, Farabow, Garrett & Dunner, LLP | All rights reserved



FINNEGAN

Last Month at the Federal Circuit

[Back to Main](#)

July 2011

The *Read* “Enhanced Damages” Standard Must Be Applied Separately from the *Seagate* “Willful Infringement” Standard

*Derrick L. Wang**

Judges: Newman (author), Clevenger, Bryson

[Appealed from D. Minn., Judge Schlitz]

In *Spectralytics, Inc. v. Cordis Corp.*, Nos. 09-1564, 10-1004 (Fed. Cir. June 13, 2011), the Federal Circuit affirmed the district court’s determination that the plaintiff Spectralytics, Inc.’s (“Spectralytics”) U.S. Patent No. 5,852,277 (“the ’277 patent”) was valid, that the defendants Cordis Corporation (“Cordis”) and Norman Noble, Inc. (“Noble”) willfully infringed the ’277 patent, and that calculation of damages at a 5 percent royalty rate was valid. The Court, however, vacated the district court’s denial of enhanced damages and attorneys’ fees to Spectralytics, and remanded the case for reapplication of the law on those two issues.

Spectralytics and Noble manufacture medical devices, including coronary stents. At issue in this appeal is a process for cutting surgical devices, performed prior to Spectralytics’ ’277 patent by “Swiss-style” machines. The workpiece and the cutting tool on Swiss-style machines are separately and rigidly mounted to dampen vibration, but the vibration occurring during the cutting process nevertheless causes unwanted movement of the workpiece and cutting tool, thus limiting the precision of cutting. The ’277 patent, by contrast, specifies that the workpiece be rigidly mounted directly on the cutting tool. Therefore, if the workpiece and the cutting tool do vibrate, they move in precise unison, eliminating relative movement between them and thus improving the precision and intricacy of cutting.

Spectralytics and Noble had both hoped to be selected by Cordis as a producer of surgical devices. However, after representatives of Noble toured the Spectralytics plant, Noble built a machine in which, like the ’277 patent, the workpiece was mounted directly on the cutting tool. Cordis then entered into an exclusive supply contract with Noble, agreeing to indemnify Noble for any patent infringement.

Spectralytics sued Cordis for infringement of its ’277 patent and added Noble as a defendant thirteen months later. The jury in the district court sustained the validity of the ’277 patent, found that Cordis and Noble willfully infringed the patent, and awarded damages calculated as a 5 percent royalty on Noble’s infringing sales to Cordis. The district court, however, denied Spectralytics’ motion for enhanced damages and attorneys’ fees based on the jury’s verdict of willful infringement.

On appeal, Spectralytics argued that the district court misapplied the law and thus abused its discretion when it denied Spectralytics' request for enhanced damages and attorneys' fees. On cross-appeal, the defendants argued that the district court abdicated its role as the ultimate decisionmaker in relying on the presumed jury findings of the '277 patent's nonobviousness. The defendants also argued that the 5 percent royalty was excessive.

“Seagate removed the presumption of willful infringement flowing from an infringer’s failure to exercise due care to avoid infringement, but Seagate did not change the application of the *Read* factors with respect to enhancement of damages when willful infringement under [37 U.S.C.] § 285 is found.” Slip op. at 21-22.

First, the Federal Circuit held that the district court did not err in relying on the presumed jury findings of nonobviousness. The Court explained that “[i]t is neither error nor dangerous to justice to submit legal issues to juries, *the submission being accompanied by appropriate instructions on the law from the trial judge.*” Slip op. at 7 (quoting *R.R. Dynamics, Inc. v. A. Stucki Co.*, 727 F.2d 1506, 1515 (Fed. Cir. 1984)). The Court also cited *Jurgens v. McKasy*, 927 F.2d 1552, 1557 (Fed. Cir. 1991), for the proposition that the Court leaves the presumed factual findings of the jury undisturbed if supported by substantial evidence and then examines the legal conclusion de novo in light of those findings. The Court found that the district court discussed the evidence before the jury, the jury’s presumed findings were supported by substantial evidence, and such evidence supported the jury’s conclusion that obviousness had not been proved. Therefore, the Federal Circuit held that the district court did not err in relying on the presumed jury findings.

Specifically, the Federal Circuit held that the district court did not err in concluding that the jury could have found that prior art and prior knowledge “taught away” from attaching the workpiece to the cutting tool as is specified in the '277 patent. The Court explained that whether prior art teaches away from the claimed invention is a question of fact. Additionally, although the Federal Circuit had in previous cases rejected assertions of “teaching away” on the ground that prior art did not directly warn against the claimed invention or teach that the claimed invention would not work, *e.g.*, *Baxter International, Inc. v. McGaw, Inc.*, 149 F.3d 1321, 1328 (Fed. Cir. 1998); *In re Gurley*, 27 F.3d 551, 553 (Fed. Cir. 1994), the Court here clarified that “[t]eaching away’ does not require that the prior art foresaw the specific invention that was later made, and warned against taking that path,” slip op. at 11.

The Court reasoned that the jury could have found, based on expert testimony, that Swiss-style machines taught away from “embracing” vibrations to improve cutting accuracy because all prior machines improved accuracy by “dampening” vibrations. *Id.* Thus, the Court held that, because substantial evidence such as expert testimony supported an “implicit finding of teaching away,” the district court applied the correct law. *Id.* at 11-12. The Court further noted that “teaching away” was not an essential element of a conclusion of nonobviousness, and that evidence of secondary considerations such as copying and commercial success could also be probative.

Second, the Federal Circuit held that the 5 percent royalty awarded by the jury to Spectralytics was not excessive. The Court explained that a party challenging a jury damages verdict “must show that the award is, in view of all the evidence, either so outrageously high or so outrageously low as to be unsupported as an estimation of a reasonable royalty.” *Id.* at 14 (quoting *Rite-Hite Corp. v. Kelley Co.*, 56 F.3d 1538, 1554 (Fed. Cir. 1995) (en banc)). The Court also noted that, in accordance with 35 U.S.C.

§ 284, the damages awarded should be “in no event less than a reasonable royalty for the use made of the invention by the infringer.” Because expert testimony established that a 20 percent royalty was reasonable and appropriate in light of trade practices and the economic and competitive circumstances, and given that Spectralytics did not appeal the jury’s 5 percent royalty rate, the Court concluded that the jury’s choice of a 5 percent royalty rate was not “outrageously high” and therefore not excessive.

Third, the Federal Circuit held that the district court abused its discretion in denying Spectralytics’ request for enhanced damages. In *In re Seagate Technology, LLC*, 497 F.3d 1360 (Fed. Cir. 2007) (en banc), the Federal Circuit set forth a willful infringement standard by which failure to exercise due care by obtaining an exculpatory opinion of counsel before commencing infringing activity is not of itself probative of willful infringement. However, in *Read Corp. v. Portec, Inc.*, 970 F.2d 816 (Fed. Cir. 1992), the Court set forth a “distinct and separate” enhanced damages standard by which one of the factors that may be relevant to determination of whether damages should be enhanced is whether there was adequate investigation of patent rights. *i4i Ltd. P’ship v. Microsoft Corp.*, 598 F.3d 831, 859 (Fed. Cir. 2010), cert. granted on other grounds (2010). Here, the district court applied the *Seagate* willful infringement standard when discounting the *Read* enhanced damages criterion of whether there was adequate investigation of adverse patent rights. Therefore, the Federal Circuit held that, because the district court misapplied the willful infringement standard to the separate determination of whether to enhance damages after willful infringement is found, the district court erred.

Finally, the Federal Circuit held that the district court erred in denying Spectralytics’ request for attorneys’ fees. The Court explained that, although attorneys’ fees are not mandatory when willful infringement has been found, precedent establishes that the Court should explain its decision not to award attorneys’ fees. Because the district court did not separately analyze the issue of attorneys’ fees but instead denied attorneys’ fees in conjunction with denial of enhanced damages, the Court held that reconsideration of the request for attorneys’ fees was warranted.

Accordingly, the Court affirmed the judgment of validity, infringement, and the royalty rate for measurement of damages. The Court vacated the denial of enhanced damages and attorneys’ fees, and remanded the case for redetermination of those two issues.

**Derrick L. Wang is a Summer Intern at Finnegan.*

The logo for the law firm Finnegan, consisting of the word "FINNEGAN" in a bold, green, sans-serif font.

If you have any questions or need additional information, please contact:

[Esther H. Lim](#), Editor-in-Chief

[Joyce Craig](#), Assistant Editor

[Elizabeth D. Ferrill](#), Assistant Editor

[Bart A. Gerstenblith](#), Assistant Editor

Washington, DC • Atlanta, GA • Cambridge, MA • Palo Alto, CA • Reston, VA • Brussels • Shanghai • Taipei • Tokyo

www.finnegan.com

Copyright © 2011 Finnegan, Henderson, Farabow, Garrett & Dunner, LLP | All rights reserved

The logo for Finnegan, featuring the word "FINNEGAN" in large, white, sans-serif capital letters. The letters are superimposed over a background of several dark brown, leather-bound book spines, suggesting a legal or intellectual property focus.

Last Month at the Federal Circuit

[Back to Main](#)

July 2011

Claim Terms Held Are Not Means-Plus-Function Limitations When Claim Language, in View of Written Description, Recites Sufficiently Definite Structure

*Hin M. Au**

Judges: Lourie (author), Prost, Moore
[Appealed from D. Del., Judge Robreno]

In *Inventio AG v. ThyssenKrupp Elevator Americas Corp.*, No. 10-1525 (Fed. Cir. June 15, 2011), the Federal Circuit reversed and remanded the district court's grant of SJ of invalidity based on a determination that certain claim limitations were means-plus-function limitations subject to 35 U.S.C. § 112, ¶ 6 and were indefinite for lack of disclosure of corresponding structure.

Inventio AG ("Inventio") sued ThyssenKrupp Elevator Americas Corporation, ThyssenKrupp Elevator Corporation, and ThyssenKrupp Elevator Manufacturing Incorporated (collectively "ThyssenKrupp") for infringement of U.S. Patent Nos. 6,892,861 ("the '861 patent") and 6,935,465 ("the '465 patent"). The patents are directed to a modernized elevator system that allows a passenger at the boarding floor to enter the desired destination when requesting an elevator instead of just pressing an up or down arrow. The patents also disclose a process for modernization that replaces the original floor call transmitters (the "up/down" buttons) with new floor terminals incorporating the modernized elevator system. In addition, the patents disclose the back-end technology ("modernizing device" and "computing unit") that interfaces with both the new floor terminals and the conventional elevator control to operate the modernized elevator system. Specifically, the written descriptions show how the "computing unit" and the internal components of the "modernizing device" are connected to each other and to the elevator control, and how the modernized elevator system functions during operation. During claim construction, the district court concluded that the terms "modernizing device" and "computing unit" were indefinite. In reaching this conclusion, the district court concluded that both terms lacked sufficiently definite structure to avoid 35 U.S.C. § 112, ¶ 6.

On appeal, the Federal Circuit first explained that the word "means" is central to the means-plus-function claim analysis. First, "[t]he use of the term 'means' triggers a rebuttable presumption that § 112, ¶ 6 governs the construction of the claim term." Slip op. at 9 (citing *TriMed, Inc. v. Stryker Corp.*, 514 F.3d 1256, 1259 (Fed. Cir. 2008)). "Conversely, where, as here, the claim language does not recite the term 'means,' [the Court] presume[s] that the limitation does not invoke § 112, ¶ 6." *Id.* (quoting *Personalized Media Commc'ns, LLC v. ITC*, 161 F.3d 696, 703-04 (Fed. Cir. 1998)). The Court further explained that the presumption flowing from the absence of the term "means" can be rebutted if the challenger

demonstrates that the claim term either “fails to ‘recite sufficiently definite structure’ or recites ‘function without reciting sufficient structure for performing that function.’” *Id.* (quoting *CCS Fitness v. Brunswick Corp.*, 288 F.3d 1359, 1369 (Fed. Cir. 2002)).

“Accordingly, it is proper to consult the intrinsic record, including the written description, when determining if a challenger has rebutted the presumption that a claim lacking the term ‘means’ recites sufficiently definite structure.” Slip op. at 12.

The parties disagreed as to whether the determination of “sufficiently definite structure” focused on the claim language in isolation or on the claim language in light of the written description. ThyssenKrupp argued that the “sufficiently definite structure” analysis depends on whether the claim language “specifies the exact structure that performs the functions in question without need to resort to other portions of the specification or extrinsic evidence for an adequate understanding of the structure.” *Id.* at 10 (quoting *TriMed*, 514 F.3d at 1259-60). Inventio, on the other hand, argued that the Court should consider the intrinsic record to determine if a claim term that lacks the word “means” is subject to § 112, ¶ 6.

The Federal Circuit agreed with Inventio, holding that “it is proper to consult the intrinsic record, including the written description, when determining if a challenger has rebutted the presumption that a claim lacking the term ‘means’ recites sufficiently definite structure.” *Id.* at 12. The Court rejected ThyssenKrupp’s reading of *TriMed* because “*TriMed* does not preclude consideration of the written description, prosecution history, and extrinsic evidence” *Id.* Relying on *Personalized Media*, 161 F.3d at 704, the Court explained that the presumption can be rebutted if the evidence intrinsic and any relevant extrinsic evidence warrant, and noted that “considering intrinsic and extrinsic evidence is usually helpful.” Slip op. at 11 (citing *MIT v. Abacus Software*, 462 F.3d 1344, 1354 (Fed. Cir. 2006)).

Because the Court looks to the words of the claims themselves, the written description, the prosecution history, and relevant extrinsic evidence to determine the proper scope of a claim, the Court agreed with Inventio that the terms “modernizing device” and “computing unit” presumptively connote sufficiently definite structure to those of skill in the art, and that ThyssenKrupp had not carried its burden of overcoming this strong presumption. *Id.* at 13, 16. In so doing, the Court rejected ThyssenKrupp’s reliance on dicta in *Personalized Media* and *MIT* that the term “device” is a generic structural term that typically does not connote sufficiently definite structure. The Court instead referenced *Linear Technology Corp. v. Impala Linear Corp.*, 379 F.3d 1311, 1320-21 (Fed. Cir. 2004), in which a claimed “circuit,” coupled with a description of the circuit’s operation in the claims, connoted sufficiently definite structure to skilled artisans to avoid the application of § 112, ¶ 6. Slip op. at 13. The Court found that, similar to the claims in *Linear*, Inventio’s claims describe how the “modernizing device” functions as an electrical circuit that receives signals, processes signals, and outputs signals to other components in the patented system. The Court also found that written descriptions depict the modernizing device and its internal components, and show how the elements are connected to the elevator control and computing unit components of the elevator system, thereby conveying structure. Thus, the Court concluded that “this is not a case where a claim nakedly recites a ‘device’ and the written description fails to place clear structural limitations on the ‘device.’” *Id.* at 15.

The Court also rejected ThyssenKrupp’s reliance on *Brown v. Baylor Healthcare System*, 381 F. App’x 981, 983-84 (Fed. Cir. 2010), for its argument that a claimed computer is not sufficient structure to perform the claimed functions as a matter of law. The Court explained that “*Brown* did not hold, as a

matter of law, that a claimed ‘computer’ is not sufficiently definite structure to avoid the application of § 112, ¶ 6,” and that “whether claim language invokes § 112, ¶ 6 depends on how those skilled in the art would understand the structural significance of that claim language, assessed against the presumptions that flow from a drafter’s choice to employ or not employ the term ‘means.’” Slip op. at 18.

The Court concluded that, unlike the claims in *Brown*, Inventio’s claims describe how the computing unit is connected to the modernizing device and the floor terminals of the elevator system, and while the written description refers to the computing unit as a computer, it thoroughly explains the steps that a computer program product would execute. Furthermore, as claims are not drafted in “means for” format, the Court found that the inventor’s decision to avoid the term “means” raises a strong presumption that the claimed “computing unit” connotes sufficiently definite structure to those skilled in the art. *Id.* Thus, the Court concluded that ThyssenKrupp failed to meet its burden of showing the claims are structurally devoid. Accordingly, the Federal Circuit reversed the district court’s SJ determination that the claimed “modernizing device” and “computing unit” limitations were means-plus-function limitations subject to 35 U.S.C. § 112, ¶ 6, and remanded for further proceedings.

**Hin M. Au is a Summer Intern at Finnegan.*

FINNEGAN

If you have any questions or need additional information, please contact:

[Esther H. Lim](#), Editor-in-Chief

[Joyce Craig](#), Assistant Editor

[Elizabeth D. Ferrill](#), Assistant Editor

[Bart A. Gerstenblith](#), Assistant Editor

Washington, DC • Atlanta, GA • Cambridge, MA • Palo Alto, CA • Reston, VA • Brussels • Shanghai • Taipei • Tokyo

www.finnegan.com

Copyright © 2011 Finnegan, Henderson, Farabow, Garrett & Dunner, LLP | All rights reserved



FINNEGAN

Last Month at the Federal Circuit

[Back to Main](#)

July 2011

Prior Art Range Encompassing the Claimed Invention Creates a Rebuttable Presumption of Obviousness

Shana K. Cyr

Judges: Newman, Bryson (author), Gajarsa

[Appealed from D.N.J., Judge Chesler]

In *Tyco Healthcare Group LP v. Mutual Pharmaceutical Co.*, No. 10-1513 (Fed. Cir. June 22, 2011), the Federal Circuit affirmed the district court's SJ invalidating two claims of U.S. Patent No. 5,211,954 ("the '954 patent") for obviousness.

The '954 patent is directed to formulations of the drug temazepam, the relevant claims reciting "6 to 8 milligrams" and "7.5 milligrams" of crystalline temazepam. Temazepam is a hypnotic (sleep-inducing) drug marketed internationally for the treatment of insomnia since the 1970s. Tyco Healthcare Group LP and Mallinckrodt, Inc. (collectively "Tyco") hold the rights to the '954 patent and have marketed capsules containing 7.5 mg of temazepam in the United States since 1981 as Restoril®. Mutual Pharmaceutical Company, Inc. ("Mutual") filed an ANDA with the FDA, seeking approval to manufacture and sell a generic version of the 7.5 mg temazepam capsules, and Tyco sued Mutual for patent infringement.

In the district court, Tyco moved for a preliminary injunction following the FDA's tentative approval of Mutual's ANDA. The district court denied Tyco's motion, finding that Mutual's proposed product could not literally infringe the asserted claims of the '954 patent. Mutual then moved for SJ of noninfringement and invalidity. The district court granted Mutual's motion with respect to invalidity, concluding that Mutual had shown by clear and convincing evidence that the '954 patent claims were obvious because (1) Restoril® was sold in the United States in 15 and 30 mg capsules for more than a year before the priority date of the '954 patent; (2) a 1983 British National Formulary ("BNF") medical reference book directed physicians to use temazepam at a dosage between 5 and 15 mg for treatment of insomnia in the elderly; and (3) the parties did not dispute that physicians always seek to prescribe the lowest effective dose of any medication, particularly hypnotics such as temazepam.

On appeal, the Federal Circuit found that the only claim limitation not disclosed by the prior art Restoril® capsules was the claimed lower dosage of temazepam. The Court noted that the BNF medical reference taught a range of temazepam from 5 to 15 mg, which included the claimed range. The Court reiterated that "where there is a range disclosed in the prior art, and the claimed invention falls within that range, there is a presumption of obviousness" that may be rebutted "either by a showing that the prior art taught

away from the invention or by a showing of new and unexpected results relative to the prior art.” Slip op. at 6 (quoting *Iron Grip Barbell Co. v. USA Sports, Inc.*, 392 F.3d 1317, 1322 (Fed. Cir. 2004)).

“[W]here there is a range disclosed in the prior art, and the claimed invention falls within that range, there is a presumption of obviousness” that may be rebutted “either by a showing that the prior art taught away from the invention or by a showing of new and unexpected results relative to the prior art.” Slip op. at 6 (quoting *Iron Grip Barbell Co. v. USA Sports, Inc.*, 392 F.3d 1317, 1322 (Fed. Cir. 2004)).

The Federal Circuit, however, rejected each of Tyco’s arguments. First, Tyco relied on its expert’s declaration in arguing that the BNF reference did not direct a person of ordinary skill in the art to temazepam hard capsules in the 5 to 15 mg range for the effective treatment of insomnia. The Court noted that Tyco’s expert correctly described the contents of the reference, but that the efficacy of the product was irrelevant to the conclusion as to obviousness because the claims did not discuss the intended use of the capsules in a particular treatment regimen (e.g., treating insomnia). The Federal Circuit also rejected Tyco’s argument that the unclaimed property of effectiveness in treating insomnia renders the claims nonobvious, reasoning that “[t]he discovery of a new property or use of a previously known composition, even when the property and use are unobvious from the prior art, can not [sic] impart patentability to the known composition.” *Id.* at 8 (quoting *In re Spada*, 911 F.2d 705, 708 (Fed. Cir. 1990)).

Second, the Federal Circuit also rejected Tyco’s argument that the prior art as a whole taught away from a range of 6 to 8 mg. After addressing each reference individually, the Court noted that none of the references addressed the effects of temazepam on elderly patients. Since the BNF reference specifically directed readers to a lower dosage of temazepam for the elderly, even if the other references could be viewed as teaching away from the use of 7.5 mg generally, they would not cast doubt on the BNF reference’s dosage range for elderly patients.

Finally, the Federal Circuit found that Tyco’s arguments for unexpected results and commercial success did not overcome the strong prima facie evidence of obviousness. While Tyco pointed to statements in the ’954 patent specification regarding unexpected results, the Court noted that “[u]nsupported statements in the specification, however, cannot support a finding of unexpected results.” *Id.* at 14. Additionally, the Court found that Tyco’s other evidence of unexpected results and alleged commercial success of Restoril® did not overcome Mutual’s strong showing of obviousness.

Accordingly, the Federal Circuit affirmed the district court’s SJ that the asserted claims of the ’954 patent were invalid for obviousness.

FINNEGAN

If you have any questions or need additional information, please contact:

Esther H. Lim, Editor-in-Chief
Joyce Craig, Assistant Editor

Elizabeth D. Ferrill, Assistant Editor
Bart A. Gerstenblith, Assistant Editor

Washington, DC • Atlanta, GA • Cambridge, MA • Palo Alto, CA • Reston, VA • Brussels • Shanghai • Taipei • Tokyo

www.finnegan.com

Copyright © 2011 Finnegan, Henderson, Farabow, Garrett & Dunner, LLP | All rights reserved



FINNEGAN

Last Month at the Federal Circuit

[Back to Main](#)

July 2011

“Competing Patents” Not Sufficient to Confer DJ Jurisdiction

*Amanda L. Lutz**

Judges: Rader, Clevenger, Linn (author)

[Appealed from S.D. Fla., Judge Gold]

In *Creative Compounds, LLC v. Starmark Laboratories*, No. 10-1445 (Fed. Cir. June 24, 2011), the Federal Circuit affirmed the district court’s grant of SJ of infringement and validity with regard to one patent, but reversed a determination of DJ jurisdiction over a competing patent. The Court also vacated the district court’s invalidity determination as to the competing patent due to lack of jurisdiction, but affirmed the Court’s denial of leave to amend an unclean hands defense.

Creative Compounds, LLC (“Creative”) and Starmark Laboratories (“Starmark”) are competitors, having independently patented similar formulations of creatine, an amino acid derivative that is naturally present in muscle tissue. Creatine is a central component of the metabolic system. Creatine is commonly used by bodybuilders looking for a steroid-free way of improving athletic performance. The patents relate to creatine formulations that increase the bioavailability of creatine. Starmark’s U.S. Patent No. 7,109,373 (“the ‘373 patent”) is directed to creatine salts comprising two molecules of creatine acid and one molecule of dicarboxylic acid. Creative’s U.S. Patent No. 7,129,273 (“the ‘273 patent”) is directed to dicreatine malate compounds, unlike Starmark’s ‘373 patent, which claims a genus of possible creatine salts.

Creative’s ‘273 patent issued approximately one month after Starmark’s ‘373 patent issued. After receiving a notice of allowance for the ‘373 patent, Starmark’s predecessor, SAN Corporation (“SAN”), mailed letters to purchasers of dicreatine malate compounds to advise the industry that its ‘373 patent would soon issue. Creative viewed SAN’s letters as threatening and mailed its own letters to the industry regarding the soon-to-issue ‘273 patent for dicreatine malate compounds. In addition to advising the industry that it received a notice of allowance for the ‘273 patent, Creative included a letter from its patent counsel that stated that, “[e]ven if SAN is correct that a patent will issue from its application, the [‘373] patent will not be enforceable because of [Creative’s] prior inventions and work.” Slip op. at 6 (third alteration in original). Although SAN did not receive Creative’s letters, it heard about them when its customers refused to license the ‘373 patent because of them. Starmark was formed in October 2006, and all rights, title, and interest in the ‘373 patent were assigned to Starmark.

In 2007, Creative sued Starmark, seeking DJ that the ‘373 patent was invalid and not infringed. In its

answer to the complaint, Starmark alleged infringement of the '373 patent and sought DJ that the '273 patent was invalid. Starmark subsequently filed a motion for SJ on all counts. Creative then filed a motion to amend its unclean hands defense and to dismiss Starmark's DJ action concerning the '273 patent for lack of subject matter jurisdiction. The district court granted Starmark's motion for SJ on all counts and denied Creative's motion to amend and dismiss. Creative appealed on four grounds: (1) the district court's grant of SJ that the '373 patent is not invalid; (2) the district court's grant of SJ that the '373 patent is infringed; (3) the district court's denial of the motion to dismiss Starmark's DJ counterclaim; and (4) the district court's denial of Creative's motion to amend its Answer.

On appeal, the Federal Circuit first considered the validity of the '373 patent. As an initial matter, the Court rejected Creative's argument that the district court applied the wrong burden of proof for Creative to establish invalidity of Starmark's patent. Because the '273 and '373 patents were copending and there is no patentable distinction between claim 1 of the '273 patent and claim 3 of the '373 patent, Creative argued that it was entitled to prove invalidity by the preponderance of the evidence instead of by clear and convincing evidence. Starmark disagreed, arguing that the parties never stipulated to common claimed subject matter, Creative did not present evidence of common claimed subject matter, and Creative did not plead a count under 35 U.S.C. § 291 for interfering patents.

“Here, neither party filed an action under § 291, neither party established the existence of an interference, nor, as discussed above, did either party seek an adjudication at trial as to any identified common claimed subject matter.”
Slip op. at 22.

The Federal Circuit agreed with Starmark, holding that “an accused infringer cannot obtain the benefit of the lower burden of proof that prevails in an interference proceeding simply by alleging, as a defense to infringement, that the asserted patent is invalid based upon a co-pending patent unless common claimed subject matter is first identified and an adjudication of priority is sought.” *Id.* at 11. The Court confirmed that an accused infringer must prove invalidity by clear and convincing evidence under 35 U.S.C. § 282 because each claim in a patent is presumed valid.

The Federal Circuit next addressed Creative's arguments that the '373 patent is invalid under 35 U.S.C. §§ 102(e)-(g). Starmark argued that there was at least one missing element in each of Creative's invalidity theories, and the Court agreed.

Creative first argued that the '373 patent is invalid under § 102(g)(2) because of Creative's prior invention. The Court found, however, that Creative failed to prove prior conception, the prerequisite to finding prior invention, rejecting Creative's reliance on an e-mail in which there was speculation that the method of making dicreatine malate should be like that of making creatine citrate. The Court found that Creative failed to present any evidence that the e-mail would constitute conception of subject matter within the scope of even a single claim of the '373 patent. Moreover, the Court found that Creative's “bald assertion” of diligence during the eighteen months between the alleged conception and Creative's first reduction to practice failed to raise a genuine issue of material fact as to diligence, a required element of Creative's § 102(g) defense. *Id.* at 14. Accordingly, the Court rejected Creative's invalidity theory under § 102(g).

The Federal Circuit also rejected Creative's argument that Starmark derived the invention from the '273 patent inventor, Derek Cornelius, which would render the '373 patent invalid under § 102(f). In order

to establish derivation, Creative was required to prove both prior conception of the invention by another and communication of the conception to the patentee. Creative's only evidence on this issue was the deposition testimony of inventor Cornelius. The Court reminded that "an inventor's testimony respecting the facts surrounding a claim of derivation or priority of invention cannot, standing alone, rise to the level of clear and convincing proof." *Id.* at 15 (citing *Price v. Symsek*, 988 F.2d 1187, 1194 (Fed. Cir. 1993)). The Court concluded that, in the absence of any other factual basis for Creative's derivation defense, there were no genuine issues of material fact, entitling Starmark to JMOL.

The Federal Circuit also rejected Creative's third invalidity argument that the '373 patent is invalid under § 102(e), because Creative failed to provide any testimony from one skilled in the art identifying each claim element and explaining how each claim element is disclosed in the prior art references. Because Creative failed to raise a single genuine issue of material fact as to any of its three invalidity theories, the Court affirmed the grant of SJ finding the '373 patent not invalid.

The Federal Circuit next turned to Creative's argument that the process for manufacturing its creative product does not infringe Starmark's method claims in the '373 patent. The Court found, however, that, under 35 U.S.C. § 295, Creative had the burden of establishing that its product was not made by the processes claimed by Starmark. Because Creative failed to argue how or why the process employed to create its product does not infringe the '373 patent, the Court affirmed the grant of SJ of infringement.

Turning to the issue of subject matter jurisdiction over the '273 patent, the Court reminded that subject matter jurisdiction in DJ actions exists when "the facts alleged, under all the circumstances, show that there is a substantial controversy, between the parties having adverse legal interests, of sufficient immediacy and reality to warrant the issuance of a [DJ]." *Id.* at 20 (quoting *MedImmune, Inc. v. Genentech, Inc.*, 549 U.S. 118, 127 (2007)). In response to Creative's argument that the district court erred in denying Creative's motion to dismiss Starmark's DJ counterclaim of invalidity of the '273 patent, Starmark argued that the dispute concerning the two competing patents was in itself enough to show a case or controversy. The Court disagreed. The Court found that Creative never accused Starmark of infringing the '273 patent, leaving Starmark's motion for DJ unsupported. Instead, Creative sent a letter to SAN's customers before Starmark came into existence. The Court also found that no interference proceeding had been established. While the Court agreed with Starmark that a fight over competing patents can demonstrate an underlying interference cause of action under 35 U.S.C. § 291, that an interference does not require an infringement allegation, and that the district court could adjudicate the validity of either interfering patent in a § 291 action, the Court disagreed that the parties had established an interference. Neither party filed an action under § 291 and neither party established the existence of an interference or sought adjudication as to any common claimed subject matter. The Court noted that Starmark had, at most, an economic interest in clarifying its customers' rights under Creative's patents. Because such an economic interest alone cannot form the bases of an "actual controversy" under the DJ Act, the Court reversed the determination of jurisdiction.

Finally, the Federal Circuit affirmed the district court's denial of Creative's motion to amend its unclear hands defense. Because the Court found that Creative sought leave to amend nine months after the date for such amendments as set forth in the Scheduling Order, under Eleventh Circuit law, the Court concluded that the district court did not abuse its discretion in denying Creative's motion to amend.

**Amanda L. Lutz is a Summer Associate at Finnegan.*

FINNEGAN

If you have any questions or need additional information, please contact:

[Esther H. Lim](#), Editor-in-Chief

[Joyce Craig](#), Assistant Editor

[Elizabeth D. Ferrill](#), Assistant Editor

[Bart A. Gerstenblith](#), Assistant Editor

Washington, DC • Atlanta, GA • Cambridge, MA • Palo Alto, CA • Reston, VA • Brussels • Shanghai • Taipei • Tokyo

www.finnegan.com

Copyright © 2011 Finnegan, Henderson, Farabow, Garrett & Dunner, LLP | All rights reserved



FINNEGAN

Last Month at the Federal Circuit

[Back to Main](#)

July 2011

Materiality and Intent Are Not a Part of Sliding Scale in Inequitable Conduct Analysis

Constance B. Jones

Judges: Lourie (author), Bryson, Gajarsa
[Appealed from S.D. Cal., Judge Sabraw]

In *American Calcar, Inc. v. American Honda Motor Co.*, Nos. 09-1503, -1567 (Fed. Cir. June 27, 2011), the Federal Circuit affirmed the district court's grants of SJ of noninfringement, reversed the denial of JMOL on the issue of validity, vacated the decision on inequitable conduct, and remanded for consideration of inequitable conduct under the guidelines set forth in *Therasense v. Becton, Dickinson & Co.*, No. 08-1511 (Fed. Cir. May 25, 2011) (en banc).

American Calcar, Inc. ("ACI") holds fifteen patents relating to various aspects of vehicle computer systems, including allowing the user to select, obtain information, and control various features of the vehicle by touching the appropriate option on the screen. The patents can be categorized into six groups. U.S. Patent No. 6,587,759 ("the Notable Condition patent") is directed toward a system that alerts the driver when a problem arises in the vehicle. U.S. Patent No. 6,330,497 ("the Three-Status patent") relates to a system that allows a user to select an option from a list, to be shown a preview of information about the selection, and then to activate it. U.S. Patent Nos. 6,438,465 and 6,542,795 ("the Search patents") are directed to a system for performing searches on a system in a vehicle. U.S. Patent Nos. 6,754,485 and 6,987,964 ("the Car-Mail patents") relate to notifying drivers about a "faulty condition," such as a condition for which the manufacturer issues a recall. U.S. Patent No. 6,275,231 ("the Radio patent") is directed to a centralized entertainment system for use in vehicles to facilitate a user's control and management of entertainment program selection. U.S. Patent Nos. 6,577,928 and 6,524,794 ("the Service Provider patents") are directed to identifying a service provider when it is determined that a vehicle needs service. Before filing the applications for the Three-Status and Search patents, the inventors borrowed an Acura 96RL vehicle and examined the car's navigation system. Although the 96RL system is described in the "Background" section of the patent applications, the description is limited to the navigation aspect of the system, not the user interface aspects. ACI asserted its patents against American Honda Motor Company, Incorporated ("Honda").

The district court granted SJ of noninfringement of five patents, namely, the Car-Mail, Service Provider, and Radio patents, and denied Honda's motion for SJ of invalidity of the Notable Condition patent. The jury found the Three-Status patent invalid as anticipated by the 96RL and awarded ACI damages for the

patents that had been found infringed and not invalid. The jury also rendered an advisory finding of no inequitable conduct as to the Three-Status and Search patents. Following the verdict, the district court ruled on Honda's inequitable conduct motion, finding that the inventors committed inequitable conduct during prosecution of the family containing the Three-Status and Search patents, and held these patent unenforceable. In so doing, the district court held that, given that the withheld information was highly material, less evidence of intent was required to reach a finding of inequitable conduct. The district court also denied Honda's motion for JMOL of invalidity of the Notable Condition patent. ACI appealed the rulings on inequitable conduct, claim construction, and noninfringement of the Car-Mail, Service Provider, and Radio patents. Honda cross-appealed the denial of JMOL of invalidity of the Notable Condition patent.

On appeal, the Federal Circuit first considered whether the Three-Status and Search patents are unenforceable for inequitable conduct. As an initial matter, the Court concluded that the district court did not prejudice ACI by disregarding the jury's advisory verdict of no inequitable conduct. The Court reminded that inequitable conduct is equitable in nature, with no right to a jury, and that the trial court has the obligation to resolve the underlying facts of materiality and intent.

“Although the court performed a detailed analysis of the facts withheld, it made no holding that any of the inventors knew that the withheld information was in fact material and made a deliberate decision to withhold it. Instead, it relied on the sliding scale standard that we have rejected *en banc* in *Therasense*” Slip op. at 26.

The Court next explained that, to prove inequitable conduct, the accused infringer must provide evidence that the applicant (1) misrepresented or omitted material information, and (2) did so with the specific intent to deceive the PTO. Under the Court's recent decision in *Therasense*, the materiality required to establish inequitable conduct is, in general, but-for materiality. In other words, when an applicant fails to disclose prior art to the PTO, that prior art is but-for material if the PTO would not have allowed a claim had it been aware of the undisclosed prior art.

Applying this standard, the Court agreed with Honda that the undisclosed 96RL information was material to the Three-Status patent because the jury found, and the district court upheld, the asserted claims as anticipated by the 96RL system, and ACI did not appeal that decision. With regard to the Search patents, the Court found that although the jury rejected Honda's invalidity arguments based on the 96RL system, the withheld information may be material if it would have blocked patent issuance under the PTO's preponderance of the evidence standard, giving those patent claims their broadest reasonable construction. Because the Court was not able to infer that finding from the district court's opinion, it vacated the district court's findings of materiality as to the Search patents and remanded the issue.

The Federal Circuit also concluded that the district court applied an incorrect standard in determining specific intent to deceive the PTO by the ACI inventors. Under *Therasense*, the accused infringer must prove by clear and convincing evidence that the applicant knew of the reference, knew that it was material, and made a deliberate decision to withhold it. The Court found that the district court made no holding that any of the inventors knew that the withheld information was in fact material and made a deliberate decision to withhold it. Instead, the district court relied on the sliding scale standard that was rejected in *Therasense*. Accordingly, the Court vacated the district court's finding of intent and remanded the issue.

The Federal Circuit turned next to ACI's challenge to the grant of SJ of noninfringement of five of its patents. With regard to the Car-Mail patents, ACI argued that the district court improperly limited the claim term "message" based on embodiments disclosed in the patent specification. According to ACI, the term means "communication." ACI also argued that the claim term "identifier" should not have been construed as unique to each vehicle. Honda responded that the district court merely adopted the patentee's own definition in requiring that the "message" be in the format <vehicle-id>@<domain> and that a nonunique identifier would render identification meaningless. The Court agreed with Honda and affirmed the two constructions and the grant of SJ of noninfringement of the Car-Mail patents.

Regarding the Radio patent, ACI argued that the district court construed the claim term "source" too narrowly, requiring that it broadcast from a fixed location and on a specified frequency. The Court disagreed, finding that ACI's broad reading of "source" was not supported by the specification. ACI also argued that the district court erred in granting SJ of noninfringement of the Radio patent because there is a question of fact as to whether the accused XM Satellite Radio receivers meet the limitation under the DOE. The Court, however, agreed with the district court that ACI had not met its evidentiary burden to demonstrate by particularized testimony that the accused receivers perform substantially the same function in substantially the same way to obtain the same result as the claimed system. The Court, therefore, affirmed the district court's SJ of noninfringement of the Radio patent.

Turning to the Service Provider patents, the Federal Circuit considered ACI's argument that the district court imported a negative limitation into the claims. Specifically, ACI argued that the district court's construction of the terms "in response" and "while" prohibited any user action between two events in the claims. ACI contended that the term "identifying one of the plurality of providers in response to vehicle conditions" simply connotes a cause-and-effect relationship between the first and second event, and does not preclude user interaction in-between. ACI similarly argued that the phrase "selecting at least one service provider for servicing the vehicle when the vehicle needs a service" requires only that one event happen before the other. The Court agreed with Honda that the district court properly construed the claims and properly found prosecution history estoppel based on statements to the PTO distinguishing a prior art reference. ACI has argued in the PTO that, in the prior art, the identification by the processor was in response to a user request rather than to the occurrence of a maintenance condition. Further, the Court found that the language of the claim itself suggests that when a vehicle condition is detected, the processing element identifies a provider automatically as opposed to requiring further user interaction. Thus, the Court affirmed the district court's finding of noninfringement of ACI's Service Provider patents by Honda's accused systems.

The Federal Circuit next considered Honda's cross-appeal of the denial of its motion seeking JMOL that the Notable Condition patent is invalid. Honda argued that the district court erred in the construction of the claim term "prompting a user to select the option" by requiring that the system prompt for not just any option, but for the one option that would allow the user to cope with the notable event. In Honda's view, this improperly required something more than the mere display of the option and that there is no support for that in the patent specification. Under the correct construction, Honda contended, a prior art reference does exactly what the patented system does—it displays a button to bring up coping information and provides an audible alert. The Court agreed with Honda that, under a proper construction, the prior art reference anticipated the asserted claims of the Notable Condition patent. Accordingly, the Court reversed the jury's verdict and held the patent invalid as anticipated.

FINNEGAN

If you have any questions or need additional information, please contact:

[Esther H. Lim](#), Editor-in-Chief

[Joyce Craig](#), Assistant Editor

[Elizabeth D. Ferrill](#), Assistant Editor

[Bart A. Gerstenblith](#), Assistant Editor

Washington, DC • Atlanta, GA • Cambridge, MA • Palo Alto, CA • Reston, VA • Brussels • Shanghai • Taipei • Tokyo

www.finnegan.com

Copyright © 2011 Finnegan, Henderson, Farabow, Garrett & Dunner, LLP | All rights reserved



FINNEGAN

Last Month at the Federal Circuit

[Back to Main](#)

July 2011

Spotlight Info

In *American Calcar, Inc. v. American Honda Motor Co.*, Nos. 09-1503, -1567 (Fed. Cir. June 27, 2011), the Federal Circuit vacated the district court's decision on inequitable conduct and remanded for consideration of inequitable conduct under the guidelines set forth in the recent case, *Therasense v. Becton, Dickinson & Co.*, No. 08-1511 (Fed. Cir. May 25, 2011) (en banc). American Calcar, Inc. ("ACI"), holder of patents relating to various aspects of vehicle computer systems, asserted its patents against American Honda Motor Company, Incorporated ("Honda"). In finding inequitable conduct, the district court required less evidence of intent to reach a finding of inequitable conduct because certain withheld information was highly material.

On appeal, the Federal Circuit restated the but-for materiality standard announced in the *Therasense* decision. Applying this standard, the Court agreed with Honda that certain withheld information was material, because the jury found the asserted claims anticipated by that information. With respect to a second reference, the Court was not able to infer a finding of materiality from the district court's opinion and thus remanded the issue. Turning to the intent prong, the Federal Circuit concluded that the district court applied an incorrect standard under *Therasense*. Since the district court made no holding that any of the inventors knew that the withheld information was in fact material and made a deliberate decision to withhold it, the Court vacated the district court's finding of intent and remanded the issue. See the full summary in this issue.

FINNEGAN

If you have any questions or need additional information, please contact:

[Esther H. Lim](#), Editor-in-Chief

[Joyce Craig](#), Assistant Editor

[Elizabeth D. Ferrill](#), Assistant Editor

[Bart A. Gerstenblith](#), Assistant Editor

Washington, DC • Atlanta, GA • Cambridge, MA • Palo Alto, CA • Reston, VA • Brussels • Shanghai • Taipei • Tokyo

www.finnegan.com

Copyright © 2011 Finnegan, Henderson, Farabow, Garrett & Dunner, LLP | All rights reserved



FINNEGAN

Last Month at the Federal Circuit

[Back to Main](#)

July 2011

Looking Ahead

On June 27, 2011, the Supreme Court granted review in both *Hyatt v. Kappos*, 625 F.3d 1320 (Fed. Cir. 2010) (en banc), and *Novo Nordisk A/S v. Caraco Pharmaceutical Laboratories, Ltd.*, 601 F.3d 1359 (Fed. Cir. 2010).

When the PTO denies an application for a patent, the applicant may seek judicial review of that decision in one of two ways: (1) obtain direct review of the agency's determination in the Federal Circuit under 35 U.S.C. § 141; or (2) commence a civil action against the Director of the PTO in federal district court under 35 U.S.C. § 145. The questions presented in *Hyatt* are:

(1) Whether the plaintiff in a § 145 action may introduce new evidence that could have been presented to the agency in the first instance; and

(2) Whether, when new evidence is introduced under § 145, the district court may decide de novo the factual questions to which the evidence pertains, without giving deference to the prior decision of the PTO.

The Federal Circuit previously held that the district court must allow new evidence and that factual conclusions to which the evidence pertains must be decided de novo, even if previously determined by the PTO.

A brand-name manufacturer may sue an ANDA applicant for infringement if, inter alia, the ANDA seeks approval for a patented use before the brand-name manufacturer's patent has expired. The ANDA applicant may respond with a counterclaim seeking an order requiring the brand-name manufacturer to correct or delete the patent information it previously submitted on the ground that the patent does not claim either (1) the drug for which the application was approved, or (2) an approved method of using the drug. 21 U.S.C. § 355(j)(5)(C)(ii)(I). The question presented in *Novo Nordisk* is whether an ANDA applicant may assert a counterclaim under § 355(j)(5)(C)(ii)(I) by alleging that the brand-name manufacturer's patent information does not accurately and precisely describe the method of use claimed by its patent. The Federal Circuit previously held that the Hatch-Waxman Act allows only for the deletion of improperly listed patents. The petitioner here argues that the Act also allows for correction of misstatements of patent scope.

Both cases will likely be briefed over the summer, argued later this year, and decided before the

Supreme Court's term ends in June 2012.

FINNEGAN

If you have any questions or need additional information, please contact:

[Esther H. Lim](#), Editor-in-Chief

[Joyce Craig](#), Assistant Editor

[Elizabeth D. Ferrill](#), Assistant Editor

[Bart A. Gerstenblith](#), Assistant Editor

Washington, DC • Atlanta, GA • Cambridge, MA • Palo Alto, CA • Reston, VA • Brussels • Shanghai • Taipei • Tokyo

www.finnegan.com

Copyright © 2011 Finnegan, Henderson, Farabow, Garrett & Dunner, LLP | All rights reserved