

United States Court of Appeals for the Federal Circuit

APPLE INC.,
Plaintiff-Appellant

v.

WI-LAN INC.,
Defendant-Cross-Appellant

2020-2011, 2020-2094

Appeals from the United States District Court for the Southern District of California in Nos. 3:14-cv-02235-DMS-BLM, 3:14-cv-1507-DMS-BLM, Judge Dana M. Sabraw.

Decided: February 4, 2022

MARK S. DAVIES, Orrick, Herrington & Sutcliffe LLP, Washington, DC, argued for plaintiff-appellant. Also represented by BENJAMIN PAUL CHAGNON, JAMES ANGLIN FLYNN, KATHERINE M. KOPP; MAX CARTER-OBERSTONE, San Francisco, CA; THOMAS KING-SUN FU, Los Angeles, CA; SEAN C. CUNNINGHAM, ERIN GIBSON, STANLEY JOSEPH PANIKOWSKI, III, DLA Piper LLP (US), San Diego, CA.

JEFFREY A. LAMKEN, MoloLamken LLP, Washington, DC, argued for defendant-cross-appellant. Also represented by RAYINER HASHEM, LUCAS M. WALKER; LEONID

GRINBERG, New York, NY; WARREN LIPSCHITZ, MIKE MCKOOL, McKool Smith, PC, Dallas, TX.

Before MOORE, *Chief Judge*, BRYSON and PROST, *Circuit Judges*.

MOORE, *Chief Judge*.

The U.S. District Court for the Southern District of California entered a final judgment (1) that Apple infringed claims 9, 26, and 27 of U.S. Patent No. 8,457,145 and claim 1 of U.S. Patent No. 8,537,757; (2) that those claims had not been proven invalid; and (3) that awarded Wi-LAN \$85.23 million in damages. Apple appeals, and Wi-LAN cross-appeals. For the following reasons, we affirm-in-part, reverse-in-part, vacate-in-part, and remand.

BACKGROUND

I

The '145 patent is directed to allocating bandwidth in a wireless communication system. '145 patent at Abstract, 1:28–30. Wireless communication systems facilitate two-way communication between user devices (e.g., mobile phones) and an associated fixed network infrastructure (e.g., wire-line system). *Id.* at 1:36–47. The wireless network described in the '145 patent does so using subscriber units associated with the user devices. *Id.* The subscriber units communicate with a base station connected to the fixed network infrastructure. *Id.* Because each base station has limited bandwidth for transmissions to and from the subscriber units it supports, those subscriber units must share bandwidth. *Id.* at 9:8–11. To that end, the subscriber units send bandwidth requests to the base station, which then allocates bandwidth. *Id.* at 3:19–28. This process itself also requires bandwidth. The '145 patent purports to provide a bandwidth allocation method that requires less bandwidth. *Id.* at 5:41–43, 51–56; 6:65–67.

In one aspect, each subscriber unit, rather than the base station, maintains and allocates bandwidth across data queues for the physical channels it serves (e.g., data or voice), relieving the base station from performing these tasks. *Id.* at 7:39–53; 8:8–14; 22:25–38. In another aspect, each subscriber unit aggregates bandwidth requests across different queues and sends them out periodically, rather than separately passing each bandwidth request to the base station. *Id.* at 27:4–11. Asserted independent claims 9 and 26 recite:

9. A subscriber unit for a wireless communication system, wherein the wireless communication system includes a plurality of subscriber units in communication with an associated base unit, comprising:

a plurality of queues, each queue for grouping data based on the QoS; and

a media access (MAC) module configured to

set an initial value for a timer associated with a queue, and

periodically, on expiration of the value of the timer, transmit a bandwidth request indicating an amount of bandwidth required for transmitting the data from the queue.

26. A subscriber unit for a wireless communication system, comprising:

a plurality of queues for buffering user traffic according to a traffic parameter, each queue having an associated logical state;

a media access control (MAC) element capable of

transmitting an uplink (UL) bandwidth request based on the logical state of the queues during a bandwidth request opportunity, and

allocating between the queues a bandwidth allocation received in response to the UL bandwidth request, based on the current state of the queues.

The '757 patent, while unrelated to the '145 patent, is directed to similar subject matter. *See* '757 patent at Abstract, 1:27–29. The patent purports to improve signal quality and offer greater error protection in data transmission using a modulation scheme. *Id.* at 4:53–5:46. Claim 1 recites:

A subscriber station for a wireless communication system comprising:

a modem section configured to receive downlink data from a base station on a downlink link and to transmit uplink data to the base station on an uplink link shared with other subscribers stations;

a receive signal quality module configured to monitor a downlink (DL) quality parameter for the downlink data providing a parameter value; and

a control section configured to:

determine a preferred downlink physical (PHY) mode for the downlink data among a plurality of PHY modes of different degrees of robustness, the preferred downlink PHY mode being defined between a

first and a second threshold for the parameter value;

instruct the modem section to transmit to the base station an indication of the preferred downlink PHY mode;

identify in a DL sub-frame map received from the base station, a current downlink PHY mode selected for the subscriber station based on the preferred downlink PHY mode and the bandwidth available to the subscriber station on the downlink link; and

instruct the modem section to receive the downlink data based on the current downlink PHY mode,

wherein the downlink PHY mode specifies a modulation format and a forward error correction technique used for transmission of downlink data.

II

In May 2014, Apple sued Wi-LAN in the Southern District of California, seeking a declaratory judgment of non-infringement and invalidity for all claims of the '145 and '757 patents. Wi-LAN counterclaimed, alleging that certain Apple devices—including the iPhone 6, iPhone 6 Plus, iPhone 5, iPhone 5S, and iPhone 5C—infringed at least one claim of those patents based on their use of the Long-Term Evolution (LTE) wireless communication standard.¹ Wi-

¹ Apple also sought declaratory judgment, and Wi-LAN counterclaimed, on claims of other patents not at issue in this appeal.

LAN contended that its patented technology enabled Voice over Long-Term Evolution (VoLTE), which provides voice call service over a 4G LTE network.

During claim construction, the parties disputed the construction of “subscriber unit” and “subscriber station,” which they agreed should be construed the same.² Apple proposed the terms mean a “fixed or portable customer premises equipment [CPE] that wirelessly receives [uplink] bandwidth from a base station, and allocates the bandwidth across connected user devices.” J.A. 5. The district court rejected that construction in favor of Wi-LAN’s construction: “module that receives [uplink] bandwidth from a base station, and allocates the bandwidth across its user connections.” J.A. 5–7.

Apple moved for partial summary judgment of noninfringement for all accused phones equipped with Intel chips based on a 2011 license agreement between Wi-LAN and Intel. The parties agreed that the license shielded Intel and its customer Apple from liability pertaining to sales of iPhones containing Intel chipsets sold during the license term. They disagreed, however, on whether section 3.2 of that agreement extended the license in perpetuity. The district court granted Apple’s motion, reasoning that this section “specifically states that *‘the licenses granted . . . shall survive the expiration of the Term License Period.’*” J.A. 25 (alterations in original); Wi-LAN’s Opening & Response Br. 70.

Infringement and damages were tried to a jury. At trial, Wi-LAN’s damages expert, David Kennedy, applied a hypothetical-negotiation framework to compute a royalty of \$0.85 per phone, or \$145.1 million total. J.A. 10617–70. He relied largely on the testimony of Dr. Vijay Madisetti

² The parties also agreed that the terms should be construed consistently across both patents at issue. J.A. 5.

regarding the incremental benefits of the '145 patent. To measure those benefits, Dr. Madisetti tested systems that use VoLTE against the best purported noninfringing alternative, Skype. J.A. 10260–61. In particular, Dr. Madisetti compared the voice quality of each system and attributed the difference to the '145 patent. J.A. 10261–72. Mr. Kennedy's damages theory relied on his testimony.

The jury found Apple infringed claims 9, 26, and 27 of the '145 patent and claim 1 of the '757 patent and awarded Wi-LAN \$145.1 million in damages. J.A. 629–30. Apple moved for judgment as a matter of law, renewing its claim construction arguments and arguing that Wi-LAN had failed to prove infringement even under the district court's construction of subscriber unit. It also moved for a new trial on damages or, alternatively, a remittitur.

The district court denied Apple's motion for judgment as a matter of law and granted its motion for a new trial on damages or, alternatively, a remittitur. It determined that Dr. Madisetti's testimony conflated the patented technology with VoLTE generally. J.A. 35–37. Because the inventors admittedly did not invent VoLTE technology, the district court concluded Dr. Madisetti's testimony lacked a factual basis and should not have been presented to the jury. J.A. 37. Because Dr. Madisetti's testimony was essential to Wi-LAN's damages theory, the district court offered Wi-LAN a choice between remittitur to \$10 million or a new trial on damages. J.A. 38. Wi-LAN chose a new trial.

In the second damages retrial, Mr. Kennedy pivoted to a royalty rate of \$0.45 per phone based on three comparable licenses that covered the asserted patents. J.A. 15216. The jury awarded Wi-LAN a royalty rate of \$0.45 per phone resulting in total damages of \$85.23 million. J.A. 756. Apple moved for judgment as a matter of law of no damages, arguing Mr. Kennedy failed to properly apportion the comparable licenses to reflect the value of the asserted patents. J.A. 764–72. The district court denied Apple's motion. J.A.

62. Apple appeals, and Wi-LAN cross-appeals. We have jurisdiction under 28 U.S.C. § 1295(a)(1).

DISCUSSION

Apple argues the district court erred in construing the “subscriber unit” and “subscriber station” terms³ to include components of a user device. Apple also argues that there is no record evidence that the accused iPhones as sold contain a subscriber unit because they do not have the required user connections. Lastly, Apple argues that Mr. Kennedy failed to apportion for the value of the patented technology and, thus, the jury should not have been allowed to consider his testimony.

In its cross-appeal, Wi-LAN argues that the district court erred in interpreting the 2011 license agreement between Wi-LAN and Intel to grant a perpetual license for Intel to sell certain chipsets to Apple. It also argues that the district court erred in ordering a new trial on damages and asks that we reinstate the original damages verdict.

I

We start with Apple’s challenge to the district court’s construction of subscriber unit as a “module that receives [uplink] bandwidth from a base station, and allocates the bandwidth across its user connections.” We review a district court’s claim construction and its interpretations of intrinsic evidence *de novo*. *Forest Lab’ys, LLC v. Sigmapharm Lab’ys, LLC*, 918 F.3d 928, 932–33 (Fed. Cir. 2019). We review any subsidiary fact findings based on extrinsic evidence for clear error. *Id.*

A claim term is generally given its plain and ordinary meaning as understood by a skilled artisan. *See Phillips v. AWH Corp.*, 415 F.3d 1303, 1313 (Fed. Cir. 2005) (en banc).

³ For simplicity, we use the term subscriber unit to refer to both subscriber unit and subscriber station.

“We depart from the plain and ordinary meaning of claim terms based on the specification in only two instances: lexicography and disavowal.” *Hill-Rom Servs., Inc. v. Stryker Corp.*, 755 F.3d 1367, 1371 (Fed. Cir. 2014) (citing *Thorner v. Sony Computer Ent. Am. LLC*, 669 F.3d 1362, 1365 (Fed. Cir. 2012)). “To act as its own lexicographer, a patentee must clearly set forth a definition of the disputed claim term other than its plain and ordinary meaning and must clearly express an intent to redefine the term.” *Id.* (internal quotation marks omitted). Embodiments in the specification—even if there is only one embodiment—cannot limit the scope of the claims absent the patentee’s “words or expressions of manifest exclusion or restriction.” *Id.* at 1372 (quoting *Liebel-Flarsheim Co. v. Medrad, Inc.*, 358 F.3d 898, 906 (Fed. Cir. 2004)).

Rather than rely on the plain-and-ordinary meaning of “subscriber unit,” Apple claims the written description redefines that term. It argues the patentee defined “subscriber unit” as CPE. Apple points to four aspects of the intrinsic record that allegedly show this redefinition: first, the patents’ interchangeable use of CPE and subscriber unit; second, the patents’ use of CPE as the sole embodiment of the “subscriber unit”; third, the patentee’s preliminary amendment that replaced claims reciting CPE with claims reciting “subscriber unit”; and fourth, the patentee’s interchangeable use of subscriber unit with other similar terms in related patents. We are not persuaded that the record in this case shows that the patentee clearly set forth this definition of subscriber unit.⁴

First, the written description does not equate CPE and subscriber unit through interchangeable use. It does not

⁴ Accordingly, we need not address the second portion of Apple’s claim construction argument: that CPE excludes subcomponents of a user’s device (e.g., part of a user’s phone).

use the terms interchangeably at all. The terms are never used to describe the same facet of a device or embodiment, nor are they used to refer to the same element of a figure. *Cf. Edwards Lifesciences LLC v. Cook Inc.*, 582 F.3d 1322, 1329 (Fed. Cir. 2009) (consistent use of intraluminal graft and graft to refer to same object and figure element was “akin to a definition equating the two”). Between the two patents, they appear in the same sentence only once:

The broadband wireless communication system facilitates two-way communication between a plurality of base stations and a plurality of *fixed subscriber stations or Customer Premises Equipment (CPE)*.

'145 patent at 2:1–4 (emphasis added). And that sentence does little to explain the relationship between a subscriber station and a CPE because it relates to *fixed* subscriber stations. Even then, it is unclear whether the sentence describes fixed subscriber stations and CPEs as alternatives or equates the two.

Nor does the patents' use of the term CPE in specific communication system embodiments and the term subscriber unit in general communication system descriptions show interchangeability. The patents use subscriber unit to refer to a generic component of wireless communication systems in the related art. For example, they introduce a wireless communication system as simply “facilitat[ing] two-way communication between a plurality of subscriber units (fixed and portable) and a fixed network infrastructure.” *See* '145 patent at 1:36–40. Moreover, the patents explain that prior art systems typically use well-known duplexing schemes such as “time division duplexing (TDD) or frequency division duplexing (FDD)” to facilitate the exchange of information “between the base station and the *subscriber units*.” *See id.* at 1:58–64 (emphasis added). Categories of general network transmissions are likewise described in terms of subscriber units and base stations.

Id. at 1:55–58 (describing downlink and uplink transmissions).

Then in each communication system embodiment, the patents describe CPEs with specific qualities and features communicating with their respective base station. *See, e.g.*, '145 patent at 2:11–15 (describing communication between a base station and CPEs “positioned at fixed customer sites 112 throughout the coverage area”); 6:11–16 (describing CPEs that transmit incremental and aggregate bandwidth requests to associated and respective base stations). These CPEs match the description of subscriber units in the background, but, unlike subscriber units, they are never used to describe components common to communication systems broadly.

Thus, the written description merely reveals that a CPE is a type of subscriber unit, which Wi-LAN freely admits. Wi-LAN's Opening & Response Br. 34. The fact that a CPE is an example of a subscriber unit, however, does not show those terms are interchangeable. And there is no evidence that the patents accord CPE the same scope as subscriber unit. As such, Apple fails to show the terms are interchangeable.

That brings us to Apple's second argument: the patents' use of CPE as the sole embodiment of the subscriber unit is a redefinition. That argument fails because there are no “words or expressions of manifest exclusion or restriction” in the written description. *See Hill-Rom*, 755 F.3d at 1372. The patents do not describe the invention as limited to a CPE. There is no disclosure that, for example, the present invention is, includes, or refers to a CPE. *See, e.g., Edwards Lifesciences*, 582 F.3d 1322 at 1330 (“the specification frequently describes an ‘intraluminal graft’ as ‘the present invention’ or ‘this invention,’ indicating an intent to limit the invention to intraluminal devices”). Nor are there any statements expressing the advantages, importance, or essentiality of using a CPE as opposed to a

subscriber unit. *See, e.g., Techtronic Indus. Co. v. Int'l Trade Comm'n*, 944 F.3d 901, 907–10 (Fed. Cir. 2019) (the patent's focus on placement of a detector in the wall console as the objective of the invention and improvement over prior art garage door operators effected a disavowal of alternative locations). Nothing in the written description makes clear that the invention is limited to a CPE. In fact, there is some language suggesting the embodiments are not limiting. '145 patent at 8:65–67, 31:60–63; '757 patent at 2:66–3:2, 17:35–43. Absent such language, we do not import limitations from the written description into the claims. *Hill-Rom*, 755 F.3d at 1372–73.

Apple's two remaining arguments for equating subscriber unit and CPE are likewise unpersuasive. Merely replacing one claim term with another during prosecution does not alone mean the terms are equivalent or interchangeable. Similarly, Wi-LAN does not dispute it used different terms for subscriber unit (such as wireless subscriber unit, subscriber radio unit, and subscriber radio station) across its many patents. If anything, that only shows subscriber unit is interchangeable with subscriber radio station and other, similar terms. It is not evidence that *CPE* and subscriber unit (or any of its variations) are interchangeable.

In sum, our review of the intrinsic record does not support Apple's claim that subscriber unit should be construed as CPE. Apple's claim construction argument, which would confine the term to standalone devices, rises and falls with that redefinition. We reject Apple's argument and uphold the district court's construction of subscriber unit.

II

Apple next argues that the district court erred in denying its motion for judgment as a matter of law that the accused products do not infringe. Apple contends that substantial evidence does not support the jury's

infringement finding because the iPhones as sold do not have a subscriber unit under the district court’s construction of that term. Apple’s Opening Br. 42–48. We do not agree.

We review a denial of judgment as a matter of law under the law of the regional circuit. *Godo Kaisha IP Bridge 1 v. TCL Comm’n Tech. Holdings Ltd.*, 967 F.3d 1380, 1382 (Fed. Cir. 2020). The Ninth Circuit reviews such a denial de novo. *Est. of Diaz v. City of Anaheim*, 840 F.3d 592, 604 (9th Cir. 2016). We review a jury’s infringement finding for substantial evidence. *Godo Kaisha*, 967 F.3d at 1383. “A factual finding is supported by substantial evidence if a reasonable jury could have found in favor of the prevailing party in light of the evidence presented at trial.” *Id.*

Substantial evidence supports the jury’s finding that the accused iPhones as sold have a subscriber unit. The district court construed that limitation to require a “module that . . . allocates the bandwidth across its user connections.” J.A. 5–7. At trial, Wi-LAN contended that the accused iPhones meet this limitation because each has a module that allocates bandwidth across two connections: data and VoLTE. Utilizing the graphic below, Dr. Madiseti testified that the baseband processor in the accused iPhones has two LTE connections with the application processor: a VoLTE connection (green) and a data connection (blue).

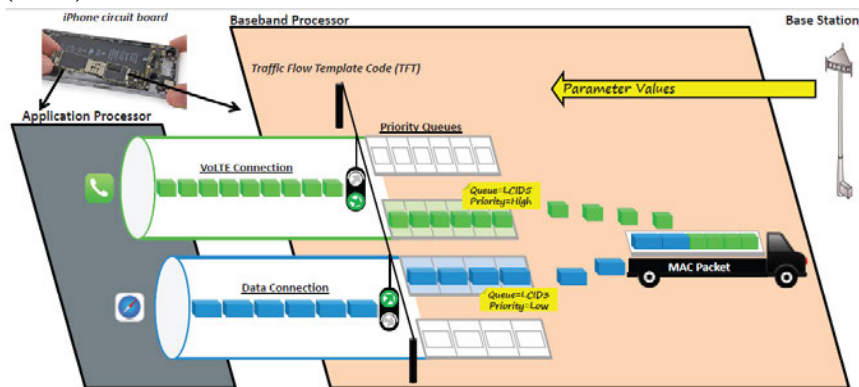

J.A. 7561, 10251–52. He further testified that the baseband processor’s media access controller (MAC) allocates bandwidth across these two connections. J.A. 10253–54. More specifically, he testified that the VoLTE connection carries voice packets from the application processor’s phone application into the baseband processor using an I2S bus, where they are stored in a priority queue, and that packets from other applications are sent over the data connection using a PCIE bus and stored in a different queue. J.A. 10287–88; Wi-LAN’s Opening & Response Br. 48–49. The MAC then reads packets from the queues, in order of priority, and transmits them to the base station. J.A. 10253–54. Finally, Dr. Madisetti testified that the physical connections between the baseband processor and application processor (i.e., the I2S bus and PCIE bus) exist “inside the iPhone as sold.” J.A. 10253. This testimony provides substantial evidence for the jury’s finding that the accused iPhones contain a subscriber unit, i.e., a module that allocates bandwidth across its user connections.

Apple argues that the data and voice connections do not exist in iPhones as sold because those connections are not established until the user turns on the phone and connects to a network with VoLTE service. Apple’s Opening Br. 44–48. And because the phrase “user connections” in the district court’s construction of subscriber unit is structural, the iPhones’ capabilities of forming these connections are irrelevant. However, substantial evidence supports the jury’s contrary finding. As Dr. Madisetti testified, the physical I2S bus provides the VoLTE connection between the baseband chip and user application, and, likewise, the physical PCIE bus provides the data connection between the same. J.A. 10253, 10257. And both components exist in the iPhone as sold. J.A. 10253.

Apple attempts to undermine Dr. Madisetti’s testimony by arguing those physical connections (i.e., I2S bus and PCIE bus) do not satisfy the user connections requirement. Citing its expert’s testimony, Apple claims the I2S

and PCIE buses stop at the edge of the applications processor, meaning the connection would be incomplete. Apple's Response & Reply Br. 21–22 (citing J.A. 11025). The jury, however, was free to weigh the testimony of Apple's expert against that of Dr. Madisetti. And we cannot say, in view of Dr. Madisetti's testimony, that the jury's determination was unreasonable.

Apple further argues the phones must be connected to a network to receive parameters to build “the ‘software structures’ necessary to establish a connection.” Apple's Opening Br. 46. To the extent that is a separate noninfringement argument, substantial evidence supports a contrary finding. Dr. Madisetti testified that no modification of hardware or software is required to perform the claimed allocation. J.A. 10258. And Apple admits that the relevant users are the iPhone applications, which run on the applications processor. Apple's Response & Reply Br. 21.

Accordingly, substantial evidence supports the jury's finding that the accused iPhones contain a subscriber unit as sold. Therefore, the district court did not err in denying Apple's motion for judgment as a matter of law on infringement.

III

Apple next challenges Mr. Kennedy's damages methodology in the second trial. We agree that his methodology was flawed, and thus, the district court abused its discretion by denying Apple's motion for a new trial.

In *Daubert v. Merrell Dow Pharmaceuticals, Inc.*, 509 U.S. 579, 589–95 (1993), the Supreme Court set forth the standards governing admissibility of expert testimony under Federal Rules of Evidence 702 and 703. The Court explained that the trial judge plays a “gatekeeping role,” *id.* at 597, which “entails a preliminary assessment of whether the reasoning or methodology underlying the testimony is scientifically valid and of whether that reasoning or

methodology properly can be applied to the facts in issue,” *id.* at 592–93. The Court emphasized that the focus “must be solely on principles and methodology, not on the conclusions that they generate.” *Id.* at 595. “[A] reasonable or scientifically valid methodology is nonetheless unreliable where the data used is not sufficiently tied to the facts of the case.” *Summit 6, LLC v. Samsung Elecs. Co., Ltd.*, 802 F.3d 1283, 1296 (Fed. Cir. 2015). Likewise, “ideal input data cannot save a methodology that is plagued by logical deficiencies or is otherwise unreasonable.” *Id.* But where the methodology is reasonable and its data or evidence are sufficiently tied to the facts of the case, the gatekeeping role of the court is satisfied. *Id.*

At trial, Wi-LAN used the hypothetical negotiation approach for calculating reasonable royalty damages under 35 U.S.C. § 284. This approach attempts to calculate the royalty rate the parties would have agreed upon had they negotiated an agreement prior to the start of the infringement. In determining a reasonable royalty, “parties frequently rely on comparable license agreements.” *Bio-Rad Labs, Inc. v. 10X Genomics Inc.*, 967 F.3d 1353, 1372 (Fed. Cir. 2020). When relying on comparable licenses to prove a reasonable royalty, we require a party to “account for differences in the technologies and economic circumstances of the contracting parties.” *VirnetX, Inc. v. Cisco Sys., Inc.*, 767 F.3d 1308, 1330 (Fed. Cir. 2014) (citation omitted). We review a district court’s decision concerning the methodology for calculating damages for an abuse of discretion. *Lucent Techs., Inc. v. Gateway, Inc.*, 580 F.3d 1301, 1310 (Fed. Cir. 2009). We review a denial of judgment as a matter of law and the denial of a motion for a new trial under the law of the regional circuit. *Id.* at 1309. In the Ninth Circuit, denial of a motion for a new trial is reviewed for abuse of discretion. *Smith v. City & Cnty. of Honolulu*, 887 F.3d 944, 949 (9th Cir. 2018).

To estimate a reasonable royalty in this case, Mr. Kennedy first culled more than 150 Wi-LAN license

agreements down to three comparable agreements⁵: the Vertu, Doro, and Unnecto license agreements. He chose those three licenses because they (1) involved phones as the licensed products; (2) became effective in 2013 or later; (3) licensed patents covering LTE or related technology; and (4) were executed after the asserted patents issued. J.A. 15220–23. In addition to licensing patents covering LTE, each agreement also licensed other patents in Wi-LAN’s portfolio.

Mr. Kennedy then set out to adjust for the differences between those licenses and the license that would have resulted from the hypothetical negotiation. He acknowledged that—unlike the Vertu, Doro, and Unnecto portfolio licenses—the hypothetical negotiation would have resulted in a license to only the ’145 and ’757 patents. J.A. 15231–32.

To account for this difference, Mr. Kennedy first sought to establish that, in practice, only a handful of valuable patents drive the royalty rate for a license, and the rest of the portfolio is included for a marginal upcharge. J.A. 15233–34. For example, he testified:

I’ve done many deals working for both sides of the table. Both parties understand and expect that the rest of the portfolio will be included, maybe for some upcharge. But it’s not dividing the patents by numbers and multiplying it by, you know, a thousand patents. It just doesn’t work that way.

⁵ Sufficient comparability is a threshold requirement for licenses to be admissible. *Elbit Sys. Land & C4I Ltd. v. Hughes Network Sys., LLC*, 927 F.3d 1292, 1299 (Fed. Cir. 2019). And Apple admits that the running-royalty licenses Mr. Kennedy relied on were admissible. Oral Arg. at 5:36–5:43, https://oralarguments.cafc.uscourts.gov/default.aspx?fl=202011_10082021.mp3.

...

You can cut out portions of the patent portfolio anyway as, Mr. Skippen testified, that just don't relate, or if they're Bluetooth, they're already licensed, so Wi-LAN is thinking, I can't collect again. So that number is not really a thousand. But whatever the number is, you're bringing forth your most valuable ones and that sets the price.

J.A. 15232–33. Mr. Skippen, on whom Mr. Kennedy relied, likewise testified that, in the industry, parties focus on a handful of “key patents,” “like throwing in the chaff with the wheat,” to provide the licensee respite and increase the royalty amount somewhere between 5 and 35 percent on average. J.A. 15157–58.

Mr. Kennedy, relying in part on Mr. Skippen's testimony, determined that the '145 and '757 patents were key patents in the three licenses for three reasons: they were specifically listed in the comparable licenses, they were discussed in negotiations, and Apple continued to use the technology after the patents were asserted against them, rather than switch to a noninfringing alternative. J.A. 15236–38; *see also* Wi-LAN Opening & Response Br. 57 (“the '145 and '757 patents were ‘crown jewels’, ‘key patents’ that phone makers like Doro ‘focus[ed] on’ in negotiations”), 60 (“the '145 and '757 patents . . . came up in negotiations, and were expressly named in the Doro and Vertu licenses”). For example, when asked about how he determined that others value the patented technology as important, Mr. Kennedy referenced Mr. Skippen's testimony that Doro “reupped [its] license in 2018, specifically talking about how these two patents . . . had been found valid and infringed.” J.A. 15237. He then pointed out that the Vertu license listed one of the asserted patents, and that the Unnecto license listed both asserted patents. J.A. 15237–38. Mr. Kennedy also emphasized that Apple's continued use of the patented technology after being found to

infringe “tells you it’s valuable to Apple or they would just take it out.” J.A. 15236–37. Based on these facts, Mr. Kennedy treated the asserted patents as the key patents. To separate the value of the key patents from the rest of the licensed portfolio, he reduced the royalty rate by 25 percent. J.A. 15238. He selected this rate based on Mr. Skippen’s testimony that, in practice, the rest of a portfolio was licensed for a 5 to 35 percent markup. *See* J.A. 15158.

Mr. Kennedy’s opinion that the asserted patents were key patents is untethered to the facts of this case. As a preliminary matter, all three licenses were obtained prior to any litigation. J.A. 15240–41. Thus, unlike Apple, the licensees did not continue to use the technology after being found to infringe. More importantly, those licenses treated the asserted patents as chaff, not wheat. For example, there is no evidence that the ’757 patent was discussed during negotiations for any of the comparable licenses.⁶ Each license divided the licensed patents between two categories: Asserted Patents and Non-Asserted Patents. None of the licenses list the ’757 patent among the “Asserted Patents,” which were the patents focused on during underlying negotiations. J.A. 861, 885, 923, 935. Two of the licenses, Doro and Vertu, do not list the ’757 patent at all. And Unnecto’s reference to the ’757 patent is easily lost in a schedule listing hundreds of Non-Asserted patents. J.A. 886, 900–22. And Mr. Skippen also expressly testified that the ’757 patent was not discussed in initial negotiations of the Doro license agreement. J.A. 15163. There is no record evidence supporting Mr. Kennedy’s assumption that the ’757 patent was a key patent. Accordingly, Mr. Kennedy’s conclusion that the ’757 patent falls into the key patent

⁶ Mr. Kennedy’s justification that the ’757 patent was later discussed in 2018 during renegotiations is immaterial because, as he acknowledged, the relevant timeframe for the hypothetical negotiation was 2013. *See* J.A. 15222.

category because it was identified as such in the comparable licenses is inconsistent with the available facts. None of the three license agreements treats the '757 patent as a key patent, and no testimony on negotiations suggested the contrary.

For similar reasons, the record does not support that the Doro or Unnecto licenses treated the '145 patent as a key patent. Neither lists the '145 patent as one of the "Asserted Patents." Doro doesn't list it at all, and as with the '757 patent, Unnecto lists the '145 patent with hundreds of other patents in the chaff. There is also no evidence that the '145 patent was discussed in negotiations for either agreement. Mr. Skippen expressly testified that the '145 patent was not discussed in negotiations of the Doro license agreement. J.A. 15163. There is, therefore, no basis upon which to conclude based upon the evidence presented that either the Doro or Unnecto license is a meaningful proxy for the royalty rate of the '145 patent.

That just leaves the Vertu license's treatment of the '145 patent. Mr. Skippen testified that the '145 patent was discussed during the Vertu license negotiations. J.A. 15166. And that license lists the '145 patent as one of the "Asserted Patents." J.A. 923, 935. However, it also lists five other "Asserted Patents." *Id.* And Mr. Kennedy failed to address the extent to which these other patents contributed to the royalty rate in the Vertu license. Yet he opined that excluding these patents (and the rest of Wi-LAN's portfolio) from the hypothetical negotiation would have netted Apple only a 25 percent discount. Mr. Kennedy's silence on these equally situated patents is troubling and makes his opinion unreliable.

Mr. Kennedy's methodological and factual errors in analyzing the comparable license agreements render his opinion untethered to the facts of this case. Thus, Mr. Kennedy's damages testimony should have been excluded.

We conclude the district court abused its discretion in denying Apple's motion for a new trial on damages.

IV

Turning to Wi-LAN's cross-appeal, the district court held that section 3.2 of the license agreement between Wi-LAN and Intel unambiguously provided Intel a perpetual license to the asserted patents. J.A. 24–25. Accordingly, it granted Apple's motion for summary judgment of no infringement for all iPhones supplied with Intel chipsets after the license agreement term expired. J.A. 25. Section 3.2 recites in part:

3.2 Term License for Wi-LAN Patent Portfolio. For the Term License Period, Wi-LAN . . . grants to Intel . . . a worldwide . . . license, without the right to sublicense, under the Licensed Patents to directly or indirectly engage in Licensed Activities. For clarity, . . . the licenses granted pursuant to this Section 3.2 with respect to Licensed Activities that were actually engaged in during the Term License Period shall survive the expiration of the Term License Period

J.A. 5432. Wi-LAN argues that this section does not provide a perpetual license for chipsets Intel sold after the agreement expired. We agree.

We review a district court's grant of summary judgment under the law of the regional circuit, here, the Ninth Circuit. *Edgewell Pers. Care Brands, LLC v. Munchkin, Inc.*, 998 F.3d 917, 919 (Fed. Cir. 2021). The Ninth Circuit reviews a district court's grant of summary judgment de novo. *Greater Yellowstone Coal. v. Lewis*, 628 F.3d 1143, 1148 (9th Cir. 2010). The relevant license agreement between Wi-LAN and Intel is governed by Delaware law. J.A. 5433. Under Delaware law, contract interpretation is a question of law that we review de novo. *GMG Cap. Invs.*,

LLC v. Athenian Venture Partners I, L.P., 36 A.3d 776, 779 (Del. 2012).

Contracts must be “read as a whole, giving meaning to each term, and avoiding an interpretation that would render any term ‘mere surplusage.’” *Sunline Com. Carriers, Inc. v. CITGO Petroleum Corp.*, 206 A.3d 836, 846 (Del. 2019). When the contract language is clear and unambiguous, “the parties’ intent is ascertained by giving the language its ordinary and usual meaning.” *Nw. Nat’l. Ins. Co. v. Esmark, Inc.*, 672 A.2d 41, 43 (Del. 1996). A contract is not ambiguous merely because the parties disagree as to its proper interpretation. *Id.* “Rather, a contract is ambiguous only when the provisions in controversy are reasonably or fairly susceptible to different interpretations or may have two or more different meanings.” *Id.* (citation omitted).

Section 3.2 of the license agreement unambiguously grants a term license. In the first sentence, Wi-LAN grants Intel a worldwide license to engage in Licensed Activities only “for the Term License Period,” which expired January 21, 2017. J.A. 5429, 5431–32. The introductory phrase of the next sentence explains the purpose of the sentence: “[f]or clarity.” J.A. 5432. The sentence goes on to clarify that “(i) the licenses granted . . . with respect to the Licensed Activities that were actually engaged in during the Term License Period shall survive the expiration of the Term License Period.” J.A. 5432. Thus, Intel continues to enjoy protection for Licensed Activities, such as past sales, engaged in prior to the license’s expiration. Our review of section 3.2 reveals no intent of the parties to extend the term license in perpetuity to Licensed Activities occurring after the license’s expiration.

Apple disagrees and argues the plain meaning of the second sentence provides a perpetual license for any future Licensed Activities of the type it actually engaged in during the license term, including sales of Intel chipsets to Apple.

Apple's Response & Reply Br. 65–67. Under Apple's interpretation, the second sentence contradicts the first sentence by extending the term of the license, which goes against the express purpose of that sentence: clarity. Moreover, Apple's interpretation inserts uncertainty into the agreement by granting perpetual licenses for unspecified categories of Licensed Activities, the scope of which could not be determined until the expiration of the agreement. This is particularly suspect given the preceding sentence unambiguously grants a license of a limited duration. Apple's interpretation is not reasonable. Because section 3.2 unambiguously grants Intel a limited license that does not extend to Licensed Activities occurring after the expiration of the agreement, we reverse the district court's grant of summary judgment of no infringement.

V

Wi-LAN next argues the district court abused its discretion in granting a new trial on damages because Dr. Madisetti's testimony about the benefits of the patented invention should not have been presented to the jury.⁷ We do not agree.

We review a district court's grant of a motion for a new trial under the law of the regional circuit. *Ericsson, Inc. v. D-Link Sys., Inc.*, 773 F.3d 1201, 1225 (Fed. Cir. 2014). The Ninth Circuit reviews such a grant for abuse of discretion. *Dees v. Cty. of San Diego*, 960 F.3d 1145, 1151 (9th Cir. 2020). Evidentiary rulings are also reviewed for an abuse of discretion. *Crowley v. Epicept Corp.*, 883 F.3d 739, 752 (9th Cir. 2018). We “must uphold the district court if any

⁷ Because Wi-LAN agrees that its challenge rises and falls with the district court's decision regarding Dr. Madisetti's testimony, we need not address its challenge to the admissibility of other evidence. Wi-LAN's Reply Br. 19.

of its grounds for granting a new trial are reasonable.” *Dees*, 960 F.3d at 1151 (citation omitted).

We see no reversible error in the district court’s reasoning. The district court focused on Dr. Madisetti’s testimony about the incremental benefits of the patented technologies, which formed the basis of Wi-LAN’s damages theory. J.A. 34–35. And it determined that Dr. Madisetti conflated the benefits of the patented technologies with VoLTE generally based on three facets of his testimony. First, Dr. Madisetti used VoLTE as a starting point to determine the benefits of the patented invention, despite an admission that the inventors of the patented technology did not invent VoLTE. J.A. 35. Second, Dr. Madisetti primarily relied on testing comparing the voice call quality of VoLTE with Skype, a purported noninfringing alternative that did not utilize VoLTE technology, and attributed the difference to the benefit of the asserted patents. J.A. 36. Lastly, Wi-LAN’s line of questioning connected VoLTE generally with the benefits of the asserted patents. J.A. 36–37. The district court cited trial testimony throughout its analysis. Because the inventors of the patented technology admittedly did not invent VoLTE, Dr. Madisetti’s testimony conflating the patented technologies with VoLTE lacked a factual basis and should not have been presented to the jury. J.A. 37. Moreover, Dr. Madisetti’s testimony was the basis for Wi-LAN’s damages theory. Thus, the district court did not abuse its discretion in granting Apple’s motion for a new trial on damages.

Wi-LAN argues Dr. Madisetti did not conflate VoLTE with the invention of the ’145 patent because it compared VoLTE and Skype call quality under multitasking or loading conditions (i.e., with multiple applications using the phone’s network connection). Wi-LAN’s Opening & Response Br. 78–80. And improved voice quality during loading is the benefit the patented technology provided. Dr. Madisetti certainly did testify concerning background applications running on the phone during testing. *See, e.g.*,

J.A. 10265. However, Dr. Madisetti made much broader statements about the value of the patented technology in his testimony, which the district court relied on in its analysis. For example, counsel for Wi-LAN engaged in the following exchange with Dr. Madisetti:

Q: Apple's use of these three inventions in the patent claims in the accused iPhones, do they improve the iPhone as a whole for voice and cellular data?

A: Yes.

Q: Better voice and higher speeds?

A: Yes.

J.A. 10271–72. Counsel also asked Dr. Madisetti:

Q: . . . You provided your expert opinion as to the benefit that Apple realizes by inclusion of these patents in the iPhone; is that correct?

A: Yes. . . .

Q: At a high level, what are those benefits?

A: You get great quality from the VoLTE, that is 2.3 MOS better. . . .

J.A. 10385–86. Our review on this issue is highly deferential, and the trial judge is in the best position to evaluate trial proceedings. Given the breadth of certain portions of Dr. Madisetti's testimony, we see no abuse of discretion in the district court's analysis.

CONCLUSION

For the above reasons, we uphold the district court's claim construction of the subscriber unit term, affirm its denial of judgment as a matter of law of noninfringement, reverse its partial summary judgment of no infringement with respect to iPhones with Intel chips, affirm its grant of a new damages trial after the first trial, vacate its denial

of a new damages trial after the second trial, and remand for a new trial on damages consistent with this opinion.

**AFFIRMED-IN-PART, REVERSED-IN-PART,
VACATED-IN-PART, AND REMANDED**

COSTS

No costs.