

**United States Court of Appeals
for the Federal Circuit**

VALVE CORPORATION,
Appellant

v.

IRONBURG INVENTIONS LTD.,
Cross-Appellant

**ANDREW HIRSHFELD, PERFORMING THE
FUNCTIONS AND DUTIES OF THE UNDER
SECRETARY OF COMMERCE FOR
INTELLECTUAL PROPERTY AND DIRECTOR OF
THE UNITED STATES PATENT AND TRADEMARK
OFFICE,**
Intervenor

2020-1315, 2020-1316, 2020-1379

Appeals from the United States Patent and Trademark
Office, Patent Trial and Appeal Board in Nos. IPR2017-
00858, IPR2017-01928.

Decided: August 17, 2021

SHARON A. ISRAEL, Shook, Hardy & Bacon, LLP, Hou-
ston, TX, argued for appellant. Also represented by KYLE
E. FRIESEN; PATRICK A. LUJIN, Kansas City, MO; REYNALDO
BARCELO, JOSHUA CHARLES HARRISON, Barcelo, Harrison &

Walker, LLP, Newport Beach, CA.

ROBERT DAVID BECKER, Manatt, Phelps, & Phillips, LLC, San Francisco, CA, argued for cross-appellant.

KAKOLI CAPRIHAN, Office of the Solicitor, United States Patent and Trademark Office, Alexandria, VA, argued for intervenor. Also represented by DANIEL KAZHDAN, THOMAS W. KRAUSE, FARHEENA YASMEEN RASHEED.

Before NEWMAN, LOURIE, and DYK, *Circuit Judges*.

DYK, *Circuit Judge*.

Valve Corporation (“Valve”) appeals two final written decisions of the Patent Trial and Appeal Board (“Board”) determining that claims of U.S. Patent No. 9,289,688 (“the ’688 patent”) and U.S. Patent No. 9,352,229 (“the ’229 patent”) were not shown to be unpatentable. Ironburg Inventions Ltd. (“Ironburg”), the owner of the ’688 patent and the ’229 patent, cross-appeals the Board’s determination that other claims of the ’688 patent were shown to be unpatentable. We affirm in part, reverse in part, vacate in part, and remand.

BACKGROUND

This appeal involves two inter partes review (“IPR”) proceedings. One concerned the ’688 patent, and the other concerned the ’229 patent. The ’688 patent and the ’229 patent have the same inventors (Simon Burgess and Duncan Ironmonger), are both owned by Ironburg, and are directed to similar subject matter, but they are otherwise not related.

In the first IPR proceeding, Valve petitioned for review of claims 1–3, 9, 10, 18–22, and 26–30 of the ’688 patent on February 7, 2017. The ’688 patent is directed to “[a]n improved controller . . . for a games console that is intended

to be held by a user in both hands in the same manner as a conventional controller” that “comprises additional controls . . . located on the rear of the controller.” ’688 patent, Abstract. Figure 5 of the ’688 patent is a rear view of an embodiment of the controller with the additional controls (numbered 11A–11D) shown as “paddle levers,” *see id.* col. 3 l. 63, col. 5 ll. 48–50, one end of which is fixed to the back of the controller by a screw (numbered 15) while the other end is moveable, *see id.* col. 6 ll. 16–21.

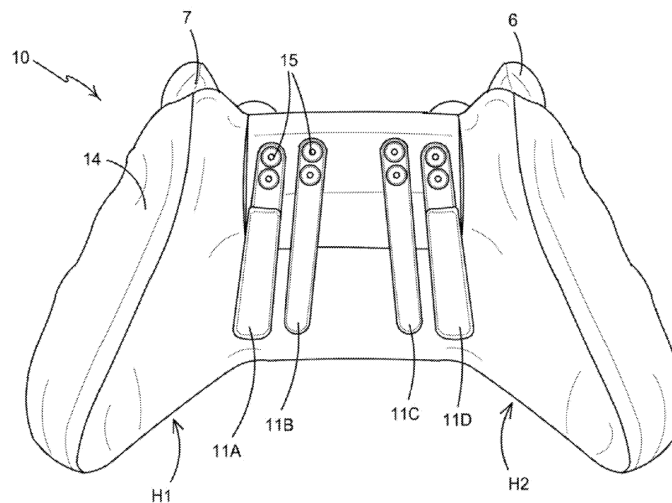

FIGURE 5

Id., fig. 5. Independent claim 1 of the ’688 patent, relevant to the cross-appeal, claims:

1. A games controller comprising:

a case; and

a plurality of controls located on a front end and a top of the case;

the case being shaped to be held in both hands of a user such that the user’s thumbs are positioned to operate controls located on the top of the case and the user’s index fingers are positioned to operate

controls located on the front end of the case;
wherein

the games controller further comprises at least one first additional control located on a back of the case in a position operable by a middle, ring or little finger of the user, the first additional control comprising a first elongate member displaceable by the user to activate a control function, wherein the first elongate member comprises a first surface disposed proximate an outer surface of the case and the first elongate member comprises a second surface opposing the first surface, the second surface being configured and arranged to be non-parallel with a portion of the outer surface of the back of the case to which the first elongate member is mounted.

Id. col. 9 ll. 28–48.

Claim 29 adds an additional limitation that is relevant to Valve’s appeal, claiming “[t]he games controller of claim 1 wherein the first elongate member is inherently resilient and flexible so as to be sufficiently displaceable to activ[ate] the control function.” *Id.* col. 12 ll. 6–8; *see also* J.A. 17 n.3 (noting that the claim mistakenly recites “active” instead of “activate”).

The Board determined that claims 1, 2, 9, 10, 20, 22, 27, 28, and 30 of the ’688 patent were shown to be unpatentable as anticipated by U.S. Patent Application Publication 2015/0238855 (“Uy”).

The Board determined that claims 18, 19, 21, 26, and 29 were not shown to be unpatentable as obvious over a claimed prior art reference (hereinafter, the “Burns article”) in combination with other references because a copy of the Burns article that Valve relied on as prior art had not been authenticated. The Board also held that claim 29 was not shown to be unpatentable because Uy did not teach

an “elongate member” that was “inherently resilient and flexible.”¹

Valve appeals the Board’s determination that claims 18, 19, 21, 26, and 29 were not shown to be unpatentable, and Ironburg cross-appeals the Board’s determination that claims 1, 2, 9, 10, 20, 22, 27, 28, and 30 were shown to be unpatentable as anticipated by Uy.

In the second IPR proceeding, Valve petitioned for review of all 24 claims of the ’229 patent on August 9, 2017. Similar to the ’688 patent, the ’229 patent is directed to “[a] hand[-]held controller for a games console,” “wherein the controller further includes at least one additional control located on a back of the controller,” ’229 patent, Abstract, where the additional controls may be “paddle levers,” *id.* col 3 ll. 52–53, col. 9 ll. 24–27. Figure 34A illustrates an embodiment of the ’229 patent’s controller, and Figure 34B illustrates the operation of the embodiment’s paddles, which may be rotated or pivoted. *See id.* col. 7 l. 66–col. 8 l. 3, col. 18 ll. 1–31.

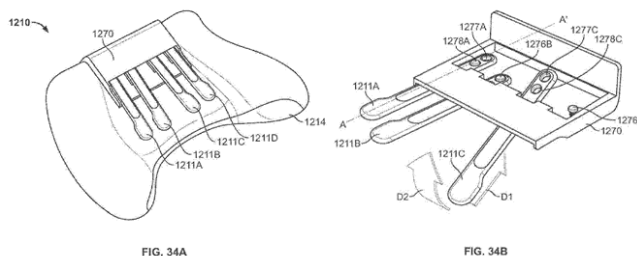

Id. figs. 34A, 34B.

¹ The Board also determined that claim 3 was not shown to be unpatentable. Valve does not appeal that determination or the Board’s determination that claim 26 of the ’688 patent was not shown to be unpatentable as anticipated by Uy. The Board also rejected Valve’s arguments regarding another reference (“Butler”), which Valve does not appeal.

Claim 1 of the '229 patent claims:

1. A hand[-]held controller for a games console comprising: an outer case;

a plurality of controls located on a front and a top of the outer case, wherein the outer case is shaped to be held in both hands of a user such that the user's thumbs are positioned to operate controls located on the front of the outer case and the user's index fingers are positioned to operate controls located on the top of the outer case; and

at least one additional control located on a back of the outer case in a position operable by the user's middle finger, the additional control comprising an elongate member which is inherently resilient and flexible such that it can be displaced by the user to activate a control function, wherein the elongate member is at least partially disposed in a respective channel located on the back of the outer case, the channel being elongated along a longitudinal dimension of the elongate member.

Id., col. 24 ll. 4–20.

The Board determined that none of the claims of the '229 patent had been shown unpatentable as anticipated by Uy because Uy did not teach “an elongate member” that “is inherently resilient and flexible,” and because Valve failed to show that a copy of the Burns article Valve relied on as a reference to show obviousness was prior art. Valve appeals.

We have jurisdiction over the appeals and cross-appeal under 28 U.S.C. § 1295(a)(4)(A) and 35 U.S.C. § 141(c).

DISCUSSION

I

An issue in both of Valve’s appeals is whether an exhibit (“the Exhibit”)² to the petition relied on by Valve was shown to be a printed publication and thus prior art under 35 U.S.C. § 102(a)(1).³ Valve relied on the Exhibit to show that claims 1, 2, 9, 10, 18, 19, 21, 26, and 28–30 of the ’688 patent and claims 1, 2, 9–17, and 21–24 of the ’229 patent were unpatentable as obvious over the combination of the Exhibit and other references. Valve asserted that the Exhibit was a printed copy of an online review of an Xbox 360 controller, titled “Review: Scuf Xbox 360 Controller” by Dave Burns, published on October 20, 2010. J.A. 2, 32, 58, 73–74, 1131. The Exhibit discloses a “controller” with “2 paddles to the back of the control pad with are [sic] made from polycarbonate,” a “plastic,” *id.* at 1132, which is relevant to various limitations, including the limitation of an

² Valve relied on two exhibits—Exhibit 1004 in the IPR proceeding for the ’688 patent and Exhibit 1003 in the IPR proceeding of the ’229 patent—as prior art. Exhibit 1004 and Exhibit 1003, each ten pages long, are identical except that three lines of text in the comments section after the article are cut off in Exhibit 1004, apparently because of how Exhibit 1004 was printed. *Compare* J.A. 1134–36 with *id.* at 3829–31. For convenience, we treat them as single exhibit.

³ The ’688 patent and the ’229 patent claim priority to provisional applications that were filed after the effective date of the amendments to §§ 102(a)–(b), 119 made by the Leahy-Smith America Invents Act (“AIA”), so the AIA versions of those subsections apply. Leahy-Smith America Invents Act, Pub. L. 112-29 § 3(b), (n), 125 Stat. 284, 285–86, 293 (2011).

“elongate member” that is “inherently resilient and flexible.”

Valve argued that the Exhibit was prior art because it was a printout of the same online article by Dave Burns—the Burns article—that was cited and enclosed in the prosecution histories of the ’688 patent, ’229 patent, and another one of Ironburg’s patents (U.S. Patent No. 8,641,525 (“the ’525 patent)),⁴ and those earlier documents were prior art. In support of its prior art argument, Valve submitted copies of the ’688 patent prosecution history, the ’229 patent prosecution history, the ’525 patent prosecution history,⁵ the ’525 patent itself, and a deposition exhibit identical to the reference found in the ’525 patent prosecution history.⁶

⁴ The ’525 patent has the same inventors (Mr. Burgess and Mr. Ironmonger) and owner (Ironburg) as the ’688 patent and ’229 patent and is directed to similar subject matter (a games controller with additional controls on the back of the controller), but it is not otherwise related to the ’688 patent or ’229 patent.

⁵ The prosecution histories of the ’525 patent and the ’688 patent were submitted as Exhibits 1040 and 1041, respectively, in the IPR proceedings for the ’688 and ’229 patents. For brevity, we cite to the exhibits for the IPR proceeding for the ’688 patent.

⁶ Ironburg argues that these documents were untimely submitted on reply, inadmissible hearsay, and not relevant. Generally, the Federal Rules of Evidence apply to IPR proceedings before the Board. 37 C.F.R. §§ 42.62(a), 42.100(a) (2020).

Ironburg’s contentions are without merit. Valve’s submission of these documents was not untimely. A petitioner may provide evidence of public accessibility of a reference after the petition stage if the patent owner raises a challenge to public accessibility. *See VidStream LLC v.*

The Board rejected Valve's showing on the ground that the Exhibit had not been shown to be the same as the asserted prior art documents in the prosecution histories. This is essentially a determination that Valve failed to prove that the Exhibit was what Valve what claimed it to be, which is an issue of authentication. *See* Fed. R. Evid. 901(a) ("To satisfy the requirement of authenticating or identifying an item of evidence, the proponent must produce evidence sufficient to support a finding that the item is what the proponent claims it is.").

On appeal, Ironburg alternatively contends that the documents in the prosecution history were not prior art because they had not been shown to be publicly accessible. We think that the record here establishes both that the Exhibit is the same reference as the prosecution history documents and that those documents were prior art.

A

We first address the Board's determination that the Exhibit was not shown to be prior art because it was not shown to be the same as the documents in the prosecution history. The Exhibit may be authenticated by "[a] comparison with an authenticated specimen by an expert witness or the trier of fact," here, the article by Dave Burns in the certified '525 patent prosecution history ("the '525 Burns article"). Fed. R. Evid. 901(b)(3). Authentication by comparison is routine. *See, e.g., In re Grand Jury Subpoena*

Twitter, Inc., 981 F.3d 1060, 1064–65 (Fed. Cir. 2020). With respect to hearsay, the documents are excluded by the hearsay rule or fall within an exception. *See* Fed. R. Evid. 803(8) (public records); Fed. R. Evid. 801(d)(2) (opposing party's statement); *Kaempe v. Myers*, 367 F.3d 958, 965 (D.C. Cir. 2004) (documents recorded by the Patent and Trademark office "are public records subject to judicial notice"). They are also clearly relevant.

Duces Tecum Dated Oct. 29, 1992, 1 F.3d 87, 93 (2d Cir. 1993) (noting that the government could authenticate the original of a calendar “simply by establishing [a] prior production of [a] copy [of the calendar] . . . and asking the trier of fact to compare the copy and the original”); *Giulio v. BV CenterCal, LLC*, 815 F. Supp. 2d 1162, 1169 (D. Or. 2011) (authenticating pages of a deposition transcript because it was “evident from comparing these pages [with an authenticated copy] that they contain identical content and are from the same deposition”); *United States v. Safavian*, 435 F. Supp. 2d 36, 39–41 (D.D.C. 2006) (authenticating emails by comparing the unauthenticated emails to authenticated emails). In *VidStream LLC v. Twitter, Inc.*, 981 F.3d 1060 (Fed. Cir. 2020), we specifically held that a comparison between the IPR copies of a reference and a version of the reference proven to be prior art was evidence that the IPR reference was prior art. *See id.* at 1066–67.

The record shows that the Exhibit and the prosecution documents are virtually identical. We first compare the Exhibit with the ’525 Burns article.

Here, a simple comparison of the Exhibit with the ’525 Burns article confirms their near identity. The text of the twelve paragraphs and the 23 images (depicting the controller and a user guide) are the same in the Exhibit and the ’525 Burns article—i.e., the prior art disclosures of these documents are the same.

It is true that the date of the Exhibit indicates that the article was “[p]osted[] 6 years ago,” J.A. 1131, while the ’525 Burns article bears a date of “October 20, 2010,” *id.* at 2002. The difference in dates does not bear on the subject matter being disclosed, which is identical in each document. Moreover, the difference in dates is consistent with a date of access for the Exhibit that is later than the ’525 Burns article and does not suggest that the Exhibit is materially different. Ironburg identifies no other substantive difference between the two.

Despite Valve's request that the Board make the comparison, the Board declined to compare the '525 Burns article with the Exhibit. The Board appears to have held that it was not obligated to compare the two because Valve provided no testimony that the two were identical. There is no requirement that such testimony be supplied. Rule 901(b)(3) of the Federal Rules of Evidence contemplates comparison by the "trier of fact," and, as noted, that is done routinely. A comparison of the '525 Burns article with the Exhibit is not burdensome. The '525 Burns article is nine pages long, and the Exhibit is ten pages long. The article in each document is twelve paragraphs long, and has 23 images. The Board had an obligation to make the comparison, as Rule 901(b)(3) contemplates and as the cases require.

The same near identity between the Exhibit and the '525 Burns article exists in comparing the Exhibit with the other copies of the Burns article in the prosecution histories of the '688 patent and '229 patent. Ironburg argues that these documents "are not identical." Cross-Appellant's Principal and Resp. Br. 16. It points out that some of the images in the '525 Burns article and the Exhibit are missing in some of the other copies of the Burns article: namely, the copy of the Burns article provided as part of Ironburg's information disclosure statement for the application for the '688 patent ("the '688 patent IDS copy") and the copy cited by the examiner for the '229 patent ("the '229 patent prosecution copy"). See Oral Arg. at 17:14–17:49, http://oralarguments.cafc.uscourts.gov/default.aspx?fl=20-1315_06082021.mp3; J.A. 2281–96 ('688 patent IDS copy); *id.* at 4394–4414 ('229 patent prosecution copy). This difference appears to be due to how the '688 patent IDS copy and the '229 patent prosecution copy were downloaded and printed; it does not amount to "affirmative evidence challenging [the Exhibit or the '525 Burns article's] material facts." *Suffolk Techs., LLC v. AOL Inc.*, 752 F.3d 1358, 1365–66 (Fed. Cir. 2014) (holding that alterations of time

stamps and email addresses in a reproduction of a news-group post asserted as prior art were insufficient to create a genuine issue of material fact concerning the post).⁷

We conclude that the Exhibit is substantively the same as the copies of the Burns article in the prosecution histories of the '525 patent and the '688 and '229 patents.

B

The Board did not determine whether the copies of the Burns article were printed publications, but Ironburg argues that Valve failed to show that the copies of the Burns article in the prosecution histories were prior art because they were not shown to be publicly accessible before the priority date. We disagree. There is overwhelming evidence that at least the '525 Burns article is prior art, and thus, the Exhibit, which is substantively the same, is also prior art.

“Whether a reference qualifies as a ‘printed publication’ under section 102 is a legal conclusion based on underlying factual findings.” *M & K Holdings, Inc. v. Samsung Elecs. Co.*, 985 F.3d 1376, 1379 (Fed. Cir. 2021) (quoting *Jazz Pharms., Inc. v. Amneal Pharms., LLC*, 895

⁷ The Board discredited Valve’s argument that the Exhibit was the same as other copies of the Burns article that displayed or could be located with the Wayback Machine URL because the “URL listed on [the Exhibit] refers to a URL on the xboxer360.com domain, not the Webarhive URL on the web.archive.org domain.” J.A. 51–52, 91–92. As the Board itself recognized, “URLs are not prior art materials themselves, but merely addresses that might permit a user to access information via the internet.” *Id.* at 52, 92. The '525 patent examiner’s documentation for the '525 Burns article makes clear that the two URLs both led to the Burns article at the time the examiner conducted the search.

F.3d 1347, 1356 (Fed. Cir. 2018)). “We review the Board’s legal determinations de novo, but we review the Board’s factual findings underlying those determinations for substantial evidence.” *Jazz*, 895 F.3d at 1355 (citations omitted).

“In an IPR, the petitioner bears the burden of establishing by a preponderance of the evidence that a particular document is a printed publication.” *Nobel Biocare Servs. AG v. Intradent USA, Inc.*, 903 F.3d 1365, 1375 (Fed. Cir. 2018), *as amended* (Sept. 20, 2018). For a reference to qualify as a printed publication, “before the critical date the reference must have been sufficiently accessible to the public interested in the art.” *Constant v. Advanced Micro-Devices, Inc.*, 848 F.2d 1560, 1568 (Fed. Cir. 1988).

The earliest priority date for the ’688 patent is April 14, 2014, which is the filing date of the provisional application to which the ’688 patent claims priority. *See* 35 U.S.C. § 119(e)(1); 37 C.F.R. § 1.78(a)(3) (2020). May 22, 2013, is the earliest of the filing dates of the two provisional applications to which the ’229 patent claims priority and is therefore the earliest priority date for that patent. *See* ’229 patent, col. 1 ll. 5–10; ’229 patent prosecution history, Application Data Sheet at 3.⁸ We conclude that the Exhibit would be prior art for both patents if it were publicly accessible before May 22, 2013, and that fact may be shown by

⁸ Ironburg asserts that May 5, 2013, is the earliest priority date for the ’229 patent, citing the Board’s decision. *See* Cross-Appellant’s Principal and Resp. Br. 5 (citing J.A. 73–85). The Board’s decision for the ’229 patent IPR proceeding states that “the earliest priority date of the ’229 patent” is “May 5, 2013,” but this appears to be an error. J.A. 73. The earliest filing date that the ’229 patent claims priority to is May 22, 2013. *See* ’229 patent, col. 1 ll. 5–10; ’229 patent prosecution history, Application Data Sheet at 3.

establishing that the '525 Burns article (which is the same as the Exhibit) is prior art.

There is overwhelming evidence that the '525 Burns article was publicly accessible on October 20, 2010, more than two years before the critical date. First, Mr. Burgess, a co-inventor of the '525, '688, and '229 patents, provided a declaration about the Burns article during the prosecution of the '525 patent and testified about the '525 Burns article during a deposition in later district court litigation.⁹

In his declaration and deposition testimony, Mr. Burgess explained that he facilitated the publication of the Burns article and intended that the Burns article reach the general public in order to promote his business. According to Mr. Burgess's deposition testimony, Mr. Burns "worked for an online magazine . . . called Xboxer 360." J.A. 2646 (Mr. Burgess's deposition testimony). "At the time of publication of the Burns article, [Burgess] was an owner of a business operating under the name 'Scuf Control.'" *Id.* at 2022 (Mr. Burgess's declaration). "Scuf Control sent Dave Burns a controller, about which he wrote the online review, which is the Burns article . . ." *Id.* (emphasis omitted). Mr. Burgess "gave it . . . away to promote the business," the purpose being to encourage publication of an article about the controller and thereby sell controllers. *Id.* at 2648. Mr. Burns "reviewed [Burgess's] video game controller." *Id.* at 2646 (Mr. Burgess's deposition testimony). The promotional purpose of the Burns article is clear from its last sentence, which reads, "For more info and to buy

⁹ During the deposition, Mr. Burgess testified about exhibit 64 of the deposition, which is the same as the '525 Burns article except with grainier text and images, and which Mr. Burgess "recognize[d]" and "believe[d]" was "the review of [Mr. Burgess's] controller." J.A. 2647; *compare id.* at 2000–08 ('525 Burns article) *with id.* at 2796–2805 (deposition Exhibit 64).

visit <http://www.scufcontrol.com/>.” *Id.* at 2004 (’525 Burns article); *see also id.* at 2647–49 (Mr. Burgess’s deposition testimony); *id.* at 2800 (deposition exhibit).

We have previously held that where a publication’s purpose is “dialogue with the intended audience,” that purpose indicates public accessibility. *Suffolk Techs., LLC v. AOL Inc.*, 752 F.3d 1358, 1365 (Fed. Cir. 2014) (noting that a newsgroup posting was a printed publication). Here, the Burns article “was intended to reach the general public,” *GoPro, Inc. v. Contour IP Holding LLC*, 908 F.3d 690, 695 (Fed. Cir. 2018), so that the review could “promote” Mr. Burgess’s business. J.A. 2648. That is strong evidence that the online review was publicly accessible. *See SRI Int’l, Inc. v. Internet Sec. Sys., Inc.*, 511 F.3d 1186, 1196 (Fed. Cir. 2008) (recognizing that “intent to publicize” is a factor “involved in the public accessibility determination”).

In *GoPro*, we held that a catalog distributed at an annual dealer trade show was prior art because “a trade show is directed to individuals interested in the commercial and developmental aspects of products.” 908 F.3d at 694. A review of a game controller in an online magazine is similarly “directed to individuals interested in the commercial and developmental aspects of products.” *Id.*

Second, the patent examiners found that the Burns article was published on October 20, 2010, more than two years before the critical date. The examiner for the ’525 patent characterized the ’525 Burns article as “published October 20, 2010.” J.A. 1994 (listing the Burns article as a non-patent document in Notice of References Cited). The first page of the ’525 patent also lists October 20, 2010, as the date Burns article was “published.” ’525 patent, References Cited, Other Publications.

Patent examiners are trained and required to determine publication dates. *See, e.g.*, MPEP § 2128 (9th ed. Rev. 10, June 2020). The patent examiner’s determination of the publication date is a “factual finding[] from a legally

authorized investigation.” Fed. R. Evid. 803(8)(A)(iii). It also “is supported by sufficient guarantees of trustworthiness.” See Fed. R. Evid. 807(a)(1).

As the Board acknowledged, the ’525 Burns article appears to have been retrieved from a resource called the “Wayback Machine.” J.A. 52 n.1, 91 n.1; see also *id.* at 1949 (examiner providing an Internet Archive web address (“URL”)), *id.* at 2001 (“Internet Archive Wayback Machine” at the bottom of a page of the ’525 Burns article). “The Wayback Machine is an online digital archive of web pages. It is run by the Internet Archive, a nonprofit library in San Francisco, California.” *Mojave Desert Holdings, LLC v. Crocs, Inc.*, 844 F. App’x 343, 346 n.2 (Fed. Cir. 2021). “[E]xaminers use ‘The Wayback [M]achine’ as a source of information to determine when a Web reference was first made available to the public.” *America Invents Act (AIA) Frequently Asked Questions*, United States Patent and Trademark Office, https://www.uspto.gov/patents/laws/america-invents-act-aia/america-invents-act-aia-frequently-asked#type-browse-faqs_2998 (last visited July 25, 2021). District courts have taken judicial notice of the contents of webpages available through the Wayback Machine “as facts that can be accurately and readily determined from sources whose accuracy cannot reasonably be questioned.” *Erickson v. Neb. Mach. Co.*, No. 15-CV-01147-JD, 2015 WL 4089849, at *1 n.1 (N.D. Cal. July 6, 2015) (comparing “copies of current versions” of websites with versions available on the Wayback Machine to determine “that the websites were substantively identical during the relevant timeframe”); see also *Pohl v. MH Sub I, LLC*, 332 F.R.D. 713, 716 (N.D. Fla. 2019) (collecting cases); *UL LLC v. Space Chariot Inc.*, 250 F. Supp. 3d 596, 603–04 & n.2 (C.D. Cal. 2017) (determining when websites began advertising a certification mark and collecting cases). We agree.

The confirmation of the ’525 Burns article’s publication date of October 20, 2010, by the ’525 patent examiner is

highly persuasive evidence of public accessibility of the '525 Burns article, and therefore, the Exhibit, by that date.

Also persuasive is the confirmation of the Burns article's publication date of October 20, 2010, by the '688 patent examiner. The examiner for the '688 patent cited the article by Mr. Burns in a non-final rejection dated October 16, 2015, enclosed a copy of the cited reference ("the '688 examiner's copy"),¹⁰ and described the reference as "published October 20, 2010." J.A. 2128, 2131–32, 2139; *see also id.* at 2142–57 ('688 examiner's copy). The "published" date of October 20, 2010, also appears on the first page of the '688 patent. '688 patent, References Cited, Other Publications.

Third, the applicants during prosecution, including Mr. Burgess, did not dispute the October 20, 2010, publication date of the Burns article, *see* J.A. 2021–22, did not dispute the '688 patent examiner's characterization of the Burns article as "prior art," J.A. 2440, confirmed the October 20, 2010, publication date in district court litigation,¹¹ and, in an IDS, stated that the Burns article was published in the year 2010. Mr. Burgess also declared the '525 Burns

¹⁰ The '688 examiner's copy has the same twelve paragraphs of text and 23 images of the controller and user guide as the '525 Burns article and the Exhibit, *compare* J.A. 2142–44 ('688 examiner's copy) with *id.* at 1131–33 (Exhibit), *id.* at 2002–05 ('525 Burns article), except that the '688 examiner's copy has duplicates of 13 of the images in higher resolution appended to the end of the article, *compare id.* at 1133 (Exhibit); *id.* at 2004–05 ('525 Burns article); *id.* at 2144 ('688 examiner's copy) *with id.* at 2145–57 (high resolution images in '688 examiner copy).

¹¹ In his deposition for later district court litigation, Mr. Burgess confirmed that "the review was in October 20, 2010." J.A. 2649.

article as “dated October 20, 2010.” *Id.* at 2021 (Mr. Burgess’s declaration).

As to the IDS, Ironburg argues that including the Burns article in its IDS does not mean that the Burns article is prior art because including a reference in an IDS is not “an admission that any reference is prior art.” Cross-Appellant’s Principal and Resp. Br. 13 (citing *ResQNet.com, Inc. v. Lansa, Inc.*, 594 F.3d 860, 866 (Fed. Cir. 2010)). The IDS is significant here, not because of its inclusion of the Burns article by the applicant, but because of the applicant’s characterization of the Burns article as being dated 2010, which is before the critical date of each patent (April 14, 2014, for the ’688 patent, and May 22, 2013, for the ’229 patent). J.A. 2159, 4233; *see also* 37 C.F.R. § 1.98(b)(5) (2020) (requiring an applicant to provide the “date” for each publication listed in an IDS).

Fourth, the ’525 patent examiner located the ’525 Burns article through an internet search. The patent examiner for the ’525 patent independently located the ’525 Burns article no later than May 15, 2013, after “conduct[ing] a brief updated search” and confirmed that it was titled “Review: Scuf Xbox 360 Controller[,]’ dated October 20, 2010, by Dave Burns.” *Id.* at 1949 (summary of an interview with the applicant mailed on May 15, 2013). As discussed above, the patent examiner provided the Internet Archive’s Wayback Machine URL for the located webpage (<http://web.archive.org/web/20101022215104/http://www.xboxer360.com/features/review-scuf-xbox-360-controller/>), as well as the URL of the webpage captured by the Wayback Machine (<http://www.xboxer360.com/features/review-scuf-xbox-360-controller/>). *Id.* at 1949 (Wayback Machine URL), 1994 (“xboxer360” URL); *see also id.* at 2001 (Wayback Machine logo included in ’525 Burns article).

The ’525 patent examiner’s confirmation that he located the reference through a “brief . . . search” for the

purposes of locating prior art, J.A. 1949, is highly probative evidence of public accessibility. “[T]he standard for public accessibility is one of ‘reasonable diligence,’ to locate the information by ‘interested members of the relevant public.’” *GoPro*, 908 F.3d at 695 (emphasis omitted) (quoting *Blue Calypso, LLC v. Groupon, Inc.*, 815 F.3d 1331, 1348 (Fed. Cir. 2016) and then *Constant v. Advanced Micro-Devices, Inc.*, 848 F.2d 1560, 1569 (Fed. Cir. 1988)).

The ’525 patent examiner accessed the Burns article no later than May 15, 2013, which is before the earliest priority date of the ’688 patent (April 14, 2014) and the earliest priority date of the ’229 patent (May 22, 2013). If an examiner could access the article before the priority date, so could the general public. The ’525 Burns article was clearly publicly accessible, and that fact proves the public accessibility of the Exhibit.

We conclude that Valve established by overwhelming evidence that the Exhibit is a copy of an online article that was publicly accessible on October 20, 2010, that the Board could not find otherwise, and therefore the Exhibit is prior art. We reverse the Board’s determination that the Exhibit was not prior art, vacate the Board’s determination that claims 18, 19, 21, 26, and 29 of the ’688 patent and claims 1, 2, 9–17, and 21–24 of the ’229 patent were not shown to be unpatentable, and remand for the Board to consider Valve’s arguments that relied on the Exhibit as to those claims.

II

Valve separately appeals the Board’s determination that Valve failed to prove that claim 29 of the ’688 patent and claims 1–15 and 18–24 of the ’229 patent were unpatentable as anticipated by Uy or as obvious over a combination of Uy and U.S. Patent No. 5,989,123 (“Tosaki”). Valve argues that the Board erred in determining that Uy did not teach a limitation common to these claims, which is an “additional control,” located on the back of the case of

the controller, '688 patent, col. 9 l. 38; '229 patent, col. 24 ll. 12–13; comprised of an “elongate member,” '688 patent, col. 9 ll. 40–41; '229 patent, col. 24 l. 14; that “is inherently resilient and flexible.” '688 patent, col. 12 ll. 6–8; '229 patent, col. 24 ll. 14–15, col. 26 ll. 25–26. The Board construed “inherently resilient and flexible” as “refer[ring] to a characteristic of the ‘elongate member’ itself.” J.A. 17; *see also id.* at 67–68.

In Valve’s petition, Valve argued that Uy taught this limitation. Uy is directed to a “game controller” with “a lever disposed on a second side of the housing,” (i.e., the back of the controller), wherein the lever “is configured to pivot” between positions, such that the pivoting of the lever activates and deactivates a switch. Uy, Abstract. Figure 5B of Uy shows the back of an embodiment of the controller with the levers 500 and 502. *See id.* ¶¶ 12, 96.

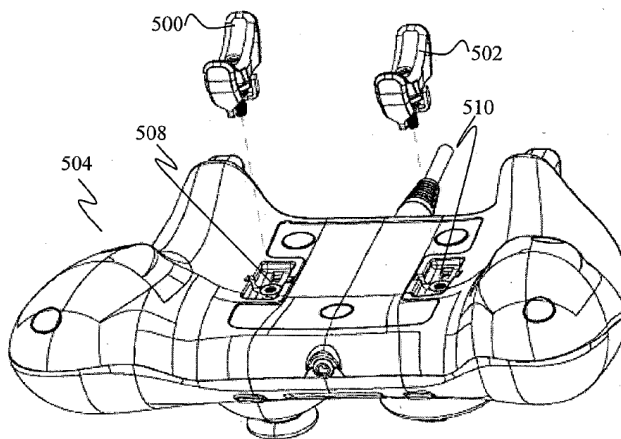

FIG. 5B

Id. fig. 5B. Valve relied on Uy’s levers, such as levers 500 and 502 and other similar embodiments, to argue that Uy taught the “elongate member” portion of the contested limitation.

As relevant here, Valve argued that Uy also taught the “inherently resilient and flexible” limitation for the elongate member because “the resilience and flexibility may be provided by a biasing spring 526 or 806.” J.A. 204, 3303, 3315. But the biasing spring of Uy (526 or 806) is separate from the elongate member that is not a part of it (500 or 802). See Uy ¶ 99 (“[T]he biasing means or spring 526 may be arranged between the screw 512 . . . and the lever 500.”); ¶ 108 (disclosing that the “lever assembly 800 includ[es] a lever 802, a securing means 804, [and] a biasing means 806.”). Figure 8B of Uy, “an exploded view of the lever assembly 800,” *id.* ¶ 108, illustrates that the biasing spring 806 and the lever 802 are separate.

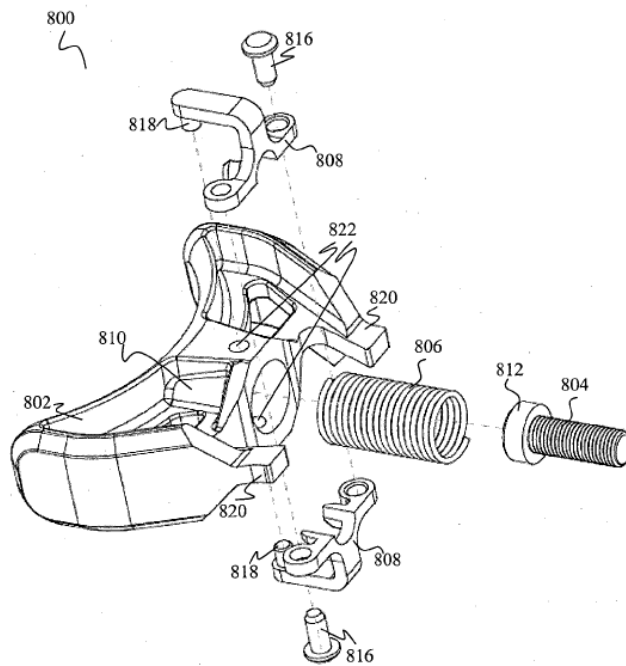

FIG. 8B

Id. fig. 8B.

The Board determined that “[b]ecause springs 526, 806 are formed separately from Uy’s levers 500, 502, 602, 604, and Valve adduce[d] no evidence that Uy’s levers alone are ‘inherently resilient and flexible,’” Valve failed to establish that Uy taught the limitation of an elongate member that is inherently resilient and flexible. J.A. 70; *see also id.* at 27–28 (similar).

Valve argues that the Board erred because “the Board construed the claims to exclude any ‘elongate member’ made from multiple parts.” Appellant’s Opening Br. 53. The Board’s construction did not exclude an “elongate member” made of multiple parts; it simply required that the elongate member itself be inherently resilient and flexible.¹² The Board’s decision was based on a factual determination that the spring of Uy is not part of the elongate member of Uy, i.e., the lever, and Valve did not argue to the Board that anything in Uy other than the spring provided flexibility and resilience. We see no error in the Board’s determination that Uy did not teach the “elongate member” that is “inherently resilient and flexible” limitation.

As a result, we affirm the Board’s determination of no unpatentability as to the claims for which Valve relied only on Uy to prove unpatentability of this limitation. We note that Valve also relied on the Exhibit (the Burns article), either alone or in combination with another reference, to

¹² While it is true that the Board stated in passing that it “disagree[d] . . . with Valve’s contention that the claimed elongate member may encompass an assembly of components,” J.A. 67, it appears that the Board was merely rephrasing its ultimate conclusion that “‘resilient’ and ‘flexible’ both describe inherent properties of the elongate member, and not other components in an assembly that may include an elongate member,” *id.* at 68 (emphasis added).

meet this limitation for claim 29 of the '688 patent and claims 1, 2, 9–15, and 21–24 of the '229 patent. As to those claims, we have remanded for the Board to consider Valve's grounds that relied on the Exhibit. As to claims 3–8 and 18–20 of the '229 patent, for which Valve relied only on Uy to teach an "elongate member" that is "inherently resilient and flexible," we affirm the Board's determination that Valve failed to prove that they were unpatentable.¹³

III

Valve argues that it is entitled to have the final written decisions of the Board remanded for review by the Acting Director of the Patent and Trademark Office under *United States v. Arthrex, Inc.*, 141 S.Ct. 1970, 1987–88 (2021). The Director opposes.

The Supreme Court's decision in *Arthrex* did not disturb our holding in *Ciena Corp. v. Oyster Optics, LLC*, 958 F.3d 1157 (Fed. Cir. 2020), in which we held that a petitioner had forfeited its Appointments Clause challenge because "unlike the patent owner in *Arthrex*, [the petitioner] requested that the Board adjudicate its petition [and] thus, affirmatively sought a ruling from the Board members, regardless of how they were appointed." *Id.* at 1159. Here, too, Valve "has forfeited its Appointments Clause challenge." *Id.*

IV

Ironburg cross-appeals the Board's determination that Uy anticipates claims 1, 2, 9, 10, 20, 22, 27, 28, and 30 of

¹³ We note that Valve conceded at oral argument that its argument that claims 3–8 and 19 of the '229 patent were unpatentable as obvious over the combination of Uy and Tosaki need not be reached if the Board's determination that Uy did not teach an elongate member that is inherently resilient and flexible is affirmed.

the '688 patent. Ironburg argues that Uy does not teach two limitations pertaining to the “elongate member” required for these claims: (1) “a first surface disposed proximate an outer surface of the case,” and (2) “a second surface opposing the first surface.” '688 patent, col. 9 ll. 43–45; *see also id.* col. 12 ll. 20–25 (using similar language for two limitations of claim 30).

A

For the first limitation, “a first surface disposed proximate an outer surface of the case,” the parties disagree on the correct construction of “disposed proximate.” Ironburg argues “disposed proximate” means that “the first surface of the elongate member is ‘positioned to face’ the outer surface of the case.” Cross-Appellant’s Principal and Resp. Br. 47. Valve argues that “disposed proximate” should be construed to mean “‘close’ to the ‘outer surface’ without having to ‘face’ the ‘outer surface.’” J.A. 9; *see* Appellant’s Reply and Resp. Br. 51–52.

The Board did “not resolve the parties’ dispute about the precise meaning of ‘disposed proximate’” because it determined that Uy taught the limitation “even if [the Board] were to adopt Ironburg’s narrower interpretation.” J.A. 9. We need not reach this issue because we conclude that Valve’s claim construction is correct, and there is no contention that the claims are patentable under that construction.

“Given that the Board did not rely on extrinsic evidence here as to claim construction, we can determine the correct construction” of the disputed limitation. *Homeland Housewares, LLC v. Whirlpool Corp.*, 865 F.3d 1372, 1375 (Fed. Cir. 2017). Here, the claim limitation “shall be given its broadest reasonable construction in light of the

specification of the patent in which it appears.” 37 C.F.R. § 42.100(b) (2018).¹⁴

The broadest reasonable interpretation of “a first surface disposed proximate an outer surface of the case” does not require, as Ironburg contends, the first surface face the outer surface of the case. The ordinary meaning of “disposed” is to be “[a]rranged, appointed, prepared, suitably placed, or situated.” *Disposed*, Oxford English Dictionary, <https://www.oed.com/view/Entry/55114> (last visited July 26, 2021). The ordinary meaning of “proximate” in the context of physical positioning is to be “[c]losely neighbouring, immediately adjacent, next, nearest.” *Proximate*, Oxford English Dictionary, <https://www.oed.com/view/Entry/153562> (last visited July 26, 2021). Under the ordinary meaning of these terms, a “first surface disposed proximate an outer surface of the case” requires that the first surface of the additional control and the outer surface of the case be arranged close or near to each other, but does not require them to be facing each other.

The specification of the ’688 patent is consistent with the ordinary meanings of “disposed” and “proximate.” For example, the specification provides that, optionally, “each first elongate member is disposed in closer proximity to a handle than a respective adjacent second elongate

¹⁴ The Patent and Trademark Office has changed the claim construction standard for IPR petitions filed on or after November 13, 2018, to be the “same claim construction standard that is used to construe the claim in a civil action in federal district court.” *Changes to the Claim Construction Standard for Interpreting Claims in Trial Proceedings Before the Patent Trial and Appeal Board*, 83 Fed. Reg. 51,340, 51,340 (Oct. 11, 2018) (codified at 37 C.F.R. § 42.100(b) (2020)). Because Valve filed its IPR petitions before November 13, 2018, the broadest reasonable interpretation standard applies.

member.” ’688 patent, col. 2 ll. 58–60. Similarly, the specification provides that, optionally, the “first elongate member comprises a first side edge and a second side edge opposing the first side edge, the first side edge being disposed in closer proximity to a respective adjacent second elongate member than the second side edge.” *Id.* col. 2 ll. 61–65. In each of these portions, the specification’s use of “disposed” and “proximity” does not require one surface to be facing the other in order to be proximate—or in close proximity—to another.¹⁵

Ironburg does not dispute that Uy teaches the limitation under Valve’s proposed construction. We affirm the Board’s determination that Uy teaches the “first surface disposed proximate an outer surface of the case” limitation.

B

In the alternative, Ironburg argues that Uy fails to teach an elongate member with “a second surface opposing the first surface.” Ironburg argues that the correct construction of the limitation is a “long thin member with substantially flat opposing surfaces.” Cross-Appellant’s Principal and Resp. Br. 57. Under the Board’s construction, the limitation’s “a second surface opposing the first surface” language “refers to two surfaces that face in generally opposite directions” and does not require the surfaces to be substantially flat. J.A. 16–17.

¹⁵ Ironburg relies on testimony from its expert, Dr. Glen Stevick, that a person of ordinary skill in the art “would understand the term ‘disposed proximate’ in the context of the ‘688 Patent to mean the first surface is ‘positioned to face’ the outer surface of the case,” J.A. 3253. “[W]here the patent documents are unambiguous, expert testimony regarding the meaning of a claim is entitled to no weight,” and that is the case here. *Vitronics Corp. v. Conceptronic, Inc.*, 90 F.3d 1576, 1584 (Fed. Cir. 1996).

We agree with the Board's construction that the "opposing" limitation is met by two surfaces that face each other or are opposite each other. As Ironburg concedes, "[t]he ordinary meaning of 'opposing' is 'facing, fronting, or opposite; (of two or more things) facing or opposite each other.'" Cross-Appellant's Principal and Resp. Br. 54 (quoting J.A. 3277). Construing the limitation to mean that the "opposing" first and second surfaces also be substantially flat would have no basis in the plain language of the claim, which only requires the first and second surfaced be "opposing." Nor is there any indication from the specification that "opposing" means "substantially flat." To the contrary, the specification uses the plain meaning of opposing, such as when it describes a "finger pad" as "the region opposing the finger nail," '688 patent, col. 8 ll. 4–6, even though a finger pad and a finger nail are not "substantially flat." J.A. 16.

Nonetheless, Ironburg argues that the first and second surfaces must be substantially flat because embodiments in the specification, Figure 9C and Figure 9B, show that "each surface of the elongated member is itself elongated and substantially flat." Cross-Appellant's Principal and Resp. Br. 54. Ironburg's proposed construction "improperly imports a limitation into the claim from a preferred embodiment." *Trebro Mfg., Inc. v. Firefly Equip., LLC*, 748 F.3d 1159, 1166 (Fed. Cir. 2014).

Ironburg also argues that Uy does not teach the limitation even under the Board's construction. The Board determined that Uy's Figure 8H shows a second surface opposing a first surface (the uppermost of the "alternative first surfaces" proposed by Valve), which meets the limitation. J.A. 24. We see no error in the Board's determination. We thus affirm the Board's determination that claims 1, 2, 9, 10, 20, 22, 27, 28, and 30 of the '688 patent are unpatentable as anticipated by Uy.

CONCLUSION

We reverse the Board's determination that the Exhibit is not prior art and vacate the determination that claims 18, 19, 21, 26, and 29 of the '688 patent and claims 1, 2, 9–17, and 21–24 of the '229 patent were not shown to be unpatentable. We remand for the Board to consider Valve's arguments that relied on the Exhibit as to those claims. We affirm the Board's determination that claims 3–8 and 18–20 of the '229 patent were not shown to be unpatentable. We also affirm the Board's determination that claims 1, 2, 9, 10, 20, 22, 27, 28, and 30 of the '688 patent were shown to be unpatentable.

**REVERSED-IN-PART, VACATED-IN-PART,
AFFIRMED-IN-PART, AND REMANDED**

COSTS

No costs.