

UNITED STATES PATENT AND TRADEMARK OFFICE

BEFORE THE PATENT TRIAL AND APPEAL BOARD

SHAW INDUSTRIES GROUP, INC.,
Petitioner,

v.

AUTOMATED CREEL SYSTEMS, INC.,
Patent Owner.

Cases IPR2013-00132 and IPR2013-00584
Patent 7,806,360 B2

Before JOSIAH C. COCKS, JUSTIN T. ARBES, and
BRIAN J. McNAMARA, *Administrative Patent Judges*.

ARBES, *Administrative Patent Judge*.

FINAL WRITTEN DECISION
35 U.S.C. § 318(a) and 37 C.F.R. § 42.73

I. BACKGROUND

Petitioner Shaw Industries Group, Inc. (“Shaw”) filed a Petition in Case IPR2013-00132 (Paper 2, “-132 Pet.”) seeking *inter partes* review of claims 1–21 of U.S. Patent No. 7,806,360 B2 (“the ’360 patent”) pursuant to 35 U.S.C. §§ 311–19. On July 25, 2013, we instituted an *inter partes* review of claims 1–3 and 5–21 on six grounds of unpatentability (Paper 9, “-132 Dec. on Inst.”). Patent Owner Automated Creel Systems, Inc. (“ACS”) filed a Patent Owner Response (Paper 18, “-132 PO Resp.”), and Shaw filed a Reply (Paper 25, “-132 Reply”).

Subsequent to institution in Case IPR2013-00132, Shaw filed a second Petition in Case IPR2013-00584 (Paper 8, “-584 Pet.”) seeking *inter partes* review of claim 4 of the ’360 patent. On December 31, 2013, we instituted an *inter partes* review of claim 4 on two grounds of unpatentability (Paper 16, “-584 Dec. on Inst.”). Shaw’s motion for joinder with the first proceeding was denied. IPR2013-00584, Paper 20. Given that the second proceeding involves only one claim, however, we set an expedited schedule that would allow the proceedings to proceed in parallel and complete roughly at the same time. *See* IPR2013-00584, Paper 17. ACS filed a Patent Owner Response (Paper 23, “-584 PO Resp.”) in Case IPR2013-00584, and Shaw filed a Reply (Paper 26, “-584 Reply”).

The parties filed motions to exclude in each proceeding, and ACS filed a motion for observation in Case IPR2013-00584, all of which are addressed herein. An oral hearing was held in both proceedings on May 1, 2014, and a transcript of the hearing is included in the record. *See* IPR2013-00132, Paper 42 (“Tr.”); IPR2013-00584, Paper 43.

Cases IPR2013-00132 and IPR2013-00584 involve the same challenged patent and parties, and there is overlap in the asserted prior art and additional evidence submitted by Shaw. To administer the proceedings more efficiently, we exercise our authority under 35 U.S.C. § 315(d) to consolidate the two proceedings for purposes of issuing one final written decision.

We have jurisdiction under 35 U.S.C. § 6(c). This final written decision is issued pursuant to 35 U.S.C. § 318(a) and 37 C.F.R. § 42.73.

For the reasons that follow, we determine that Shaw has shown by a preponderance of the evidence that claims 1–5, 8–12, 14, 19, and 20 of the ’360 patent are unpatentable, but has not shown by a preponderance of the evidence that claims 6, 7, 13, 15–18, and 21 are unpatentable.

A. The ’360 Patent

The ’360 patent¹ relates to “creels used for supplying stranded materials” (e.g., yarn used for making textiles) to a machine for “subsequent treatment” or the “fabrication of articles” from the stranded materials. Ex. 1002, col. 1, ll. 14–17. The ’360 patent describes how high-speed processing systems require a continuous, uninterrupted stream of stranded material fed from multiple yarn packages throughout a creel, but loading and maintaining a full creel “remains an extremely labor intensive operation” and can cause breaks in the material, particularly at the point where material from successive packages is joined. *Id.* at col. 1, ll. 30–44. The ’360 patent

¹ The ’360 patent issued based on U.S. Patent Application No. 12/253,398, filed on October 17, 2008, which is a continuation-in-part of U.S. Patent Application No. 11/875,254, filed on October 19, 2007, and issued as U.S. Patent No. 7,802,749.

describes a mechanism that provides a “pre-configured supply of materials, carried on movable carts, or cartridges,” for loading into a creel. *Id.* at col. 2, ll. 36–46.

Figure 12 of the '360 patent is reproduced below.

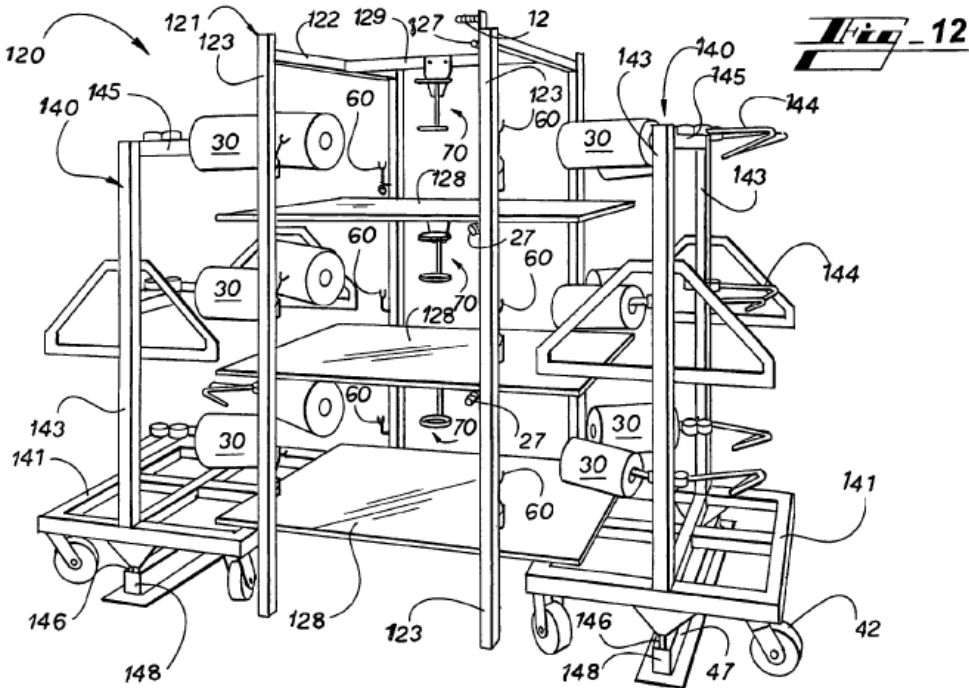

As shown in Figure 12 above, two carts 140 on either side of creel magazine frame 121 are loaded with three levels of stranded material packages 30 (two packages on each level). *Id.* at col. 8, ll. 32–52. Packages 30 are supported on support arms 144. *Id.* at col. 8, ll. 55–67. One continuous feed of stranded material is provided at a particular level by connecting the end of the material in one package to the beginning of the material in the next package and drawing material from the four packages at the level sequentially. *Id.* at col. 9, l. 64–col. 10, l. 16; Fig. 13 (depicting stranded material portions a–f from packages 30a–d used in sequence). The '360 patent also describes a replacement method whereby the empty packages in one cart are replaced while the packages in the opposite cart are being used,

and then the carts alternate roles when the opposite packages in turn are depleted. *Id.* at col. 7, l. 45–col. 8, l. 52; col. 11, l. 1–col. 12, l. 16. A cart or package is “active” (when it is being used) or “ready” (when it has been replenished and is awaiting use). *Id.* at col. 11, l. 65–col. 12, l. 9. Carts 40 have wheels 42 and are positioned at the appropriate distance from creel magazine 120 via pin 146 placed in track 148. *Id.* at col. 4, ll. 22–25; col. 9, ll. 1–13.

As shown in Figure 12, creel magazine 120 includes on each level ring guide 70 for routing the stranded material as it is drawn from packages 30. *Id.* at col. 9, ll. 14–63. Figure 19A depicts ring guide 70 in further detail, and is reproduced below:

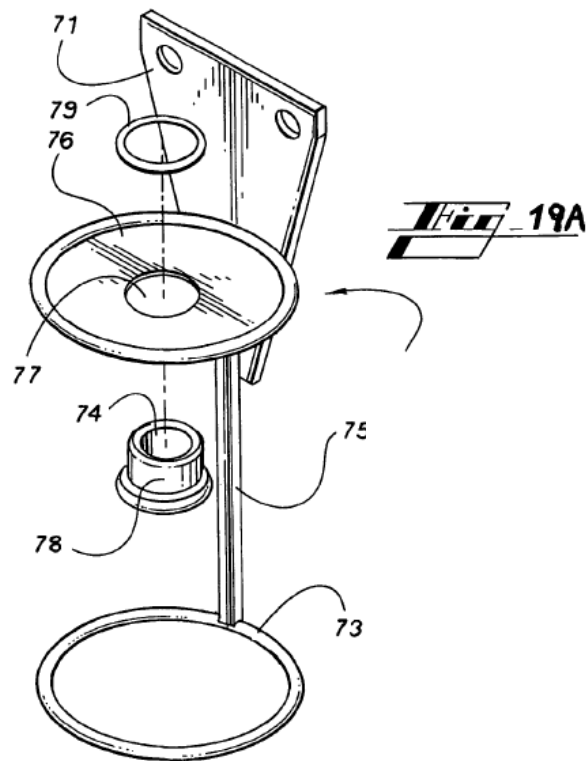

As shown in Figure 19A above, ring guide 70 comprises a lower ring having annular turning surface 73 and an upper ring having upper turning surface 74. *Id.* at col. 9, ll. 22–37. The ring shape of annular turning surface 73

allows the surface to receive stranded material from any direction (i.e., any of the four packages at that level) and control “ballooning”² when “the strands transfer across the magazine frame 121 from one cart to the other.” *Id.* at col. 5, ll. 51–61; col. 9, ll. 49–59. As stranded material is drawn out of a package, annular turning surface 73 changes the orientation of the material from horizontal to vertical, upper turning surface 74 changes it back to horizontal, secondary guide 27 (shown in Figure 12) changes it to vertical, and guide board 12 (shown in Figure 12) changes it to horizontal so that it can be processed along with the material from other magazines. *Id.* at col. 6, ll. 59–63; col. 9, l. 49–col. 10, l. 16; Figs. 16A–B.

B. Illustrative Claims

Claims 1–6 of the ’360 patent recite (paraphrasing added):

1. A creel magazine for feeding stranded material to a manufacturing process comprising:

 a magazine having a stationary magazine frame comprising a common guide for said stranded material;

 a first and a second removable cartridge positioned adjacent said magazine frame on respective opposite sides of said frame, said first removable cartridge having at least one support arm supporting an active package of stranded material thereon;

 said second removable cartridge having at least one support arm supporting a ready package of stranded material thereon;

² The ’360 patent describes the problem of “ballooning” as follows: “As will be recognized by those skilled in the art, particularly with respect to stranded materials such as yarns utilized in textiles, as the yarn is pulled from the package 30, it will unwind from package 30 and form a balloon around and at the end of the package 30.” Ex. 1002, col. 5, ll. 51–55.

wherein a trailing end of said active package is connected to a leading end of said ready package such that said stranded material is sequentially and continuously fed to said common guide from said active package then from said ready package.

2. The creel magazine of claim 1, wherein said common guide is an annular turning surface positioned to receive stranded material fed from said active package.

3. The creel magazine of claim 2, wherein said common guide further comprises an upper turning surface supported above said annular turning surface.

4. The creel magazine of claim 3, wherein said annular turning surface and said upper turning surface are separated by a distance corresponding to the diameter of said packages.

5. A creel magazine for feeding stranded material to a manufacturing process comprising:

a magazine having a stationary magazine frame comprising a common guide for said stranded material;

a first and a second removable cartridge positioned adjacent said magazine frame on respective opposite sides of said magazine frame, said first removable cartridge having at least one support arm supporting an active package of stranded material thereon;

said second removable cartridge having at least one support arm supporting a ready package of stranded material thereon wherein a trailing end of said stranded material carried by said active package is connected to a leading end of said stranded material carried by said ready package;

wherein said common guide is an annular turning surface and said stranded material is sequentially fed to said common guide from said active package then from said ready package.

6. The creel magazine of claim 5, further comprising an additional support arm supported adjacent to said at least one support arm for supporting an additional ready package on said first removable cartridge, to be selectively interposed between said active package and said ready package on said second removable cartridge to feed said stranded material.

C. Prior Art

The pending grounds of unpatentability in the instant *inter partes* reviews are based on the following prior art:

1. U.S. Patent No. 3,102,702, issued Sept. 3, 1963 (“Miller”) (Ex. 1012);³
2. U.S. Patent No. 4,572,458, issued February 25, 1986 (“Bluhm”) (Ex. 1111).
3. U.S. Patent No. 5,624,082, issued April 29, 1997 (“Ligon”) (Ex. 1010);
4. German Patent Application Publication No. DE 3429153 A1, published Feb. 28, 1985 (“Münnekehoff”) (Ex. 1005); and
5. German Patent DE 7413531, published July 31, 1975 (“Barmag”) (Ex. 1007).⁴

D. Pending Grounds of Unpatentability

The instant *inter partes* reviews involve the following grounds of unpatentability:

³ Shaw numbered its exhibits in Case IPR2013-00132 as 1001–1017, and its exhibits in Case IPR2013-00584 as 1101–1119. ACS numbered its exhibits in Case IPR2013-00132 as 2001–2005 and 2300, and its exhibits in Case IPR2013-00584 as 2101, 2102, 2301, and 2401. We use the parties’ numbering, and refer to exhibit numbers without their corresponding case number for simplicity.

⁴ We refer to “Münnekehoff” as the English translation (Ex. 1005) of the original reference (Ex. 1004), and likewise refer to “Barmag” as the English translation (Ex. 1007) of the original reference (Ex. 1006). Shaw provided affidavits attesting to the accuracy of the translations. *See* Exs. 1005, 1007; 37 C.F.R. § 42.63(b).

Reference(s)	Basis	Claim(s)
Münnekehoff	35 U.S.C. § 102(b)	1–3, 5, 8–10, 12, 14, 19, and 20
Münnekehoff and Ligon	35 U.S.C. § 103(a)	6, 7, 13, 15–18, and 21
Münnekehoff and Miller	35 U.S.C. § 103(a)	11
Münnekehoff and Bluhm	35 U.S.C. § 103(a)	4
Barmag	35 U.S.C. § 102(b)	1–3, 5, 8–10, 12, 14, 19, and 20
Barmag and Ligon	35 U.S.C. § 103(a)	6, 7, 13, 15–18, and 21
Barmag and Miller	35 U.S.C. § 103(a)	11
Barmag and Bluhm	35 U.S.C. § 103(a)	4

II. ANALYSIS

A. Claim Interpretation

In the Decisions on Institution, we interpreted various claim terms of the '360 patent as follows:

Term(s)	Interpretation
“cart” and “cartridge” (claims 1, 5, 8, 12, and 14)	a small wheeled vehicle
“removable” (claims 1, 5, and 14)	capable of being removed
“annular turning surface” (claims 2 and 5)	a ring-shaped surface that changes the direction of stranded material
“upper turning surface” (claim 3)	a surface, located above another surface, that changes the direction of stranded material

Term(s)	Interpretation
“distance corresponding to the diameter of said packages” (claim 4)	a distance that is derived from the diameter of a fully loaded package
“ring guide” (claim 9)	a guide structure having a circular shape

See -132 Dec. on Inst. 8–16; -584 Dec. on Inst. 9–11. The parties do not dispute these interpretations in their Patent Owner Responses and Replies, and we incorporate our previous analysis for purposes of this decision.

B. Claims 1–3, 5, 8–12, 14, 19, and 20

Shaw argues in its Petition in Case IPR2013-00132 that (1) claims 1–3, 5, 8–10, 12, 14, 19, and 20 are anticipated by Münnekehoff under 35 U.S.C. § 102(b); (2) claim 11 is unpatentable over Münnekehoff and Miller under 35 U.S.C. § 103(a); (3) claims 1–3, 5, 8–10, 12, 14, 19, and 20 are anticipated by Barmag under 35 U.S.C. § 102(b); and (4) claim 11 is unpatentable over Barmag and Miller under 35 U.S.C. § 103(a). -132 Pet. 9–16, 22–31, 37–38. Shaw’s allegations are supported by testimony from Youjiang Wang, Ph.D. *See* Ex. 1001. ACS, in its Patent Owner Response in Case IPR2013-00132, does not provide any argument regarding claims 1–3, 5, 8–12, 14, 19, and 20, and instead focuses solely on claims 6, 7, 13, 15–18, and 21. *See* -132 PO Resp. 12. We have reviewed Shaw’s Petition and the evidence cited therein, and are persuaded, by a preponderance of the evidence, that claims 1–3, 5, 8–12, 14, 19, and 20 are unpatentable based on the asserted grounds identified above.

C. Claims 6, 7, 13, 15–18, and 21

Shaw argues in its Petition in Case IPR2013-00132 that claims 6, 7, 13, 15–18, and 21 are unpatentable under 35 U.S.C. § 103(a) based on two combinations of references: (1) Münnekehoff and Ligon, and (2) Barmag and Ligon. -132 Pet. 18–21, 33–36. Shaw again relies on the testimony of Dr. Wang in support. *Id.* (citing Ex. 1001 ¶¶ 28–33, 55–59). We have reviewed Shaw’s Petition, ACS’s Patent Owner Response, and Shaw’s Reply, as well as the evidence discussed in each of those papers. We are not persuaded, by a preponderance of the evidence, that claims 6, 7, 13, 15–18, and 21 are unpatentable based on either asserted ground.

1. Level of Ordinary Skill in the Art

Neither party expressly states what it believes to be the level of ordinary skill in the art applicable to the ’360 patent. Based on our review of the ’360 patent, the types of problems and solutions described in the ’360 patent and cited prior art, and the testimony of the parties’ declarants,⁵ we conclude that a person of ordinary skill in the art at the time of the ’360 patent (October 2008) would have had a degree in mechanical engineering or a similar discipline, and multiple years of work experience with creels. *See, e.g.*, Ex. 1002, col. 1, l. 14–col. 2, l. 32 (stating that the ’360 patent relates to “creels used for supplying stranded materials,” and describing conventional creel systems of the time and problems with such systems, including problems with strand breakage and manual replacement of yarn

⁵ Shaw submitted testimony from Dr. Wang in each proceeding. *See* Exs. 1001, 1013, 1101, 1116. ACS submitted testimony from David Chadwick, the named inventor of the ’360 patent, and David Brookstein, Sc.D. *See* Exs. 2001, 2101, 2102.

packages); Ex. 1001 ¶¶ 3–7 (describing the background of Dr. Wang);
Ex. 2001 ¶¶ 1–8 (describing the background of Mr. Chadwick); Ex. 2102
¶¶ 2–5 (describing the background of Dr. Brookstein).

2. Ground Based on *Münnekehoff and Ligon*

a. *Münnekehoff*

Münnekehoff discloses a “[t]extile machine for the processing of thread” where each creel comprises a “stock section” and “standby section” with bobbins. Ex. 1005, Abstract. A “stock” bobbin supplies thread during operation, and a “standby” bobbin is connected at its “outermost thread end” to the “innermost thread end” of a stock bobbin. *Id.* at p. 5, ll. 3–21.⁶ Doing so allows “continuous operation” where the thread runs from the standby bobbin once the stock bobbin is depleted and “the standby bobbin [then] becomes the stock bobbin, while the empty sleeve of the previous stock bobbin is removed from the creel and replaced with a new standby bobbin.” *Id.* at p. 5, ll. 21–28.

⁶ When citing *Münnekehoff*, we refer to the page numbers in the header of the translation (Ex. 1005).

Figure 2 of Münnekehoff is reproduced below.

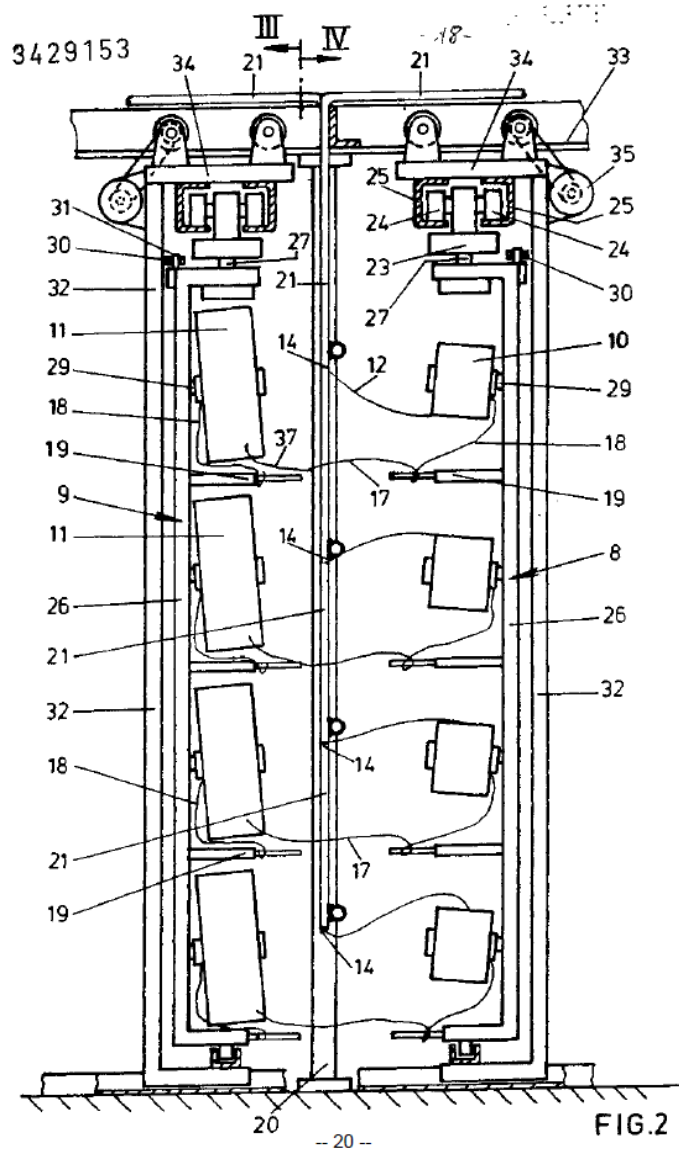

Figure 2 depicts a creel arrangement comprising bobbin holders 29, stock section 8 with stock bobbins 10 providing run-off thread 12, and standby section 9 with standby bobbins 11 providing standby thread 17. *Id.* at p. 11, l. 7–p. 12, l. 1; pp. 15–16. As shown in Figure 2, inner thread end 18 of stock bobbin 10 at each level is looped around holding rod 19 on stock section 8, and “connected, e.g. knotted,” to outer thread end 37 of standby bobbin 11 when a new standby bobbin is installed. *Id.* at p. 13, ll. 7–12.

Further, “the operator is able to grasp the thread ends 18 on the holding rods 19 of the stock section 8, and connect the ends of the threads of one standby and one stock bobbin each.” *Id.* at p. 13, ll. 13–20. Figure 2 also depicts inner thread end 18 of standby bobbin 11 “pre-positioned” at holding rod 19 on standby section 9. *Id.* at p. 11, ll. 18–24.

The arrangement shown in Figure 2 includes thread guiding tube 21 for each level of bobbins (four are shown in Figure 2). *Id.* at p. 11, ll. 26–32. Thread guiding tubes 21 each include a balloon thread guide 14 at the “mouth” where the thread enters, and are used to guide the thread from the bobbins up and to the side of the machine. *Id.*; Fig. 2 (depicting a 90-degree turn at the top of the figure). Support frames 32 for each section (stock and standby) have wheels at the top for moving along rails 33. *Id.* at p. 12, l. 29–p. 13, l. 6.

b. Ligon

Ligon discloses a “yarn creel for feeding yarn to an associated textile machine having a generally in-line yarn delivery path.” Ex. 1010, col. 2, ll. 5–8. Ligon states that as looms began operating at higher speeds, tying two yarn packages together became insufficient, and those in the textile industry began using creels with four yarn packages tied together instead. *Id.* at col. 1, ll. 25–28. Using four packages, however, required multiple changes in direction as the yarn is fed horizontally from the packages to the loom and other machinery, which could result in the yarn breaking and interrupting the textile process. *Id.* at col. 1, ll. 32–40. Specifically, “[e]ach time that the yarn changes its direction, particularly sharply, the chances of a yarn break are greatly increased because of the increased tension resulting

from increased angles.” *Id.* at col. 1, ll. 35–38. Ligon addresses this problem by “mount[ing] four yarn packages tailed together to feed yarn to a single associated textile machine generally in-line with the machine with reduced bends in the yarn delivery path.” *Id.* at col. 2, ll. 24–26. Figure 2 of Ligon is reproduced below.

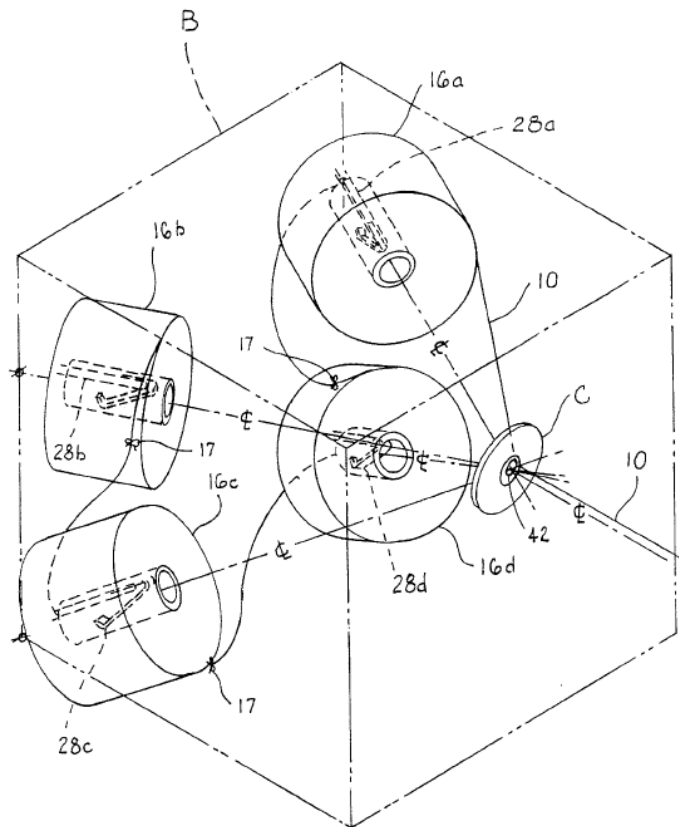

Fig. 2

Figure 2 depicts four yarn packages 16a–d on yarn package holders 28 that feed weft yarn 10 to a single eyelet 42. *Id.* at col. 4, ll. 22–27. Yarn packages 16a–d are tailed together, at point 17 of each package, such that yarn is fed sequentially through the four packages from 16a to 16d to 16c to 16b, as shown in Figure 2. *Id.* at col. 3, ll. 55–63; Figs. 2, 4. Ligon also discloses an arrangement with four vertically-spaced, “side-by-side” pairs of

yarn packages, where each pair is tailed together and fed to its own vertically-spaced eyelet. *Id.* at col. 5, ll. 2–14.

c. Analysis

Claims 6, 7, 13, 15–18, and 21 each recite the transfer of stranded material from one package to another in two ways: on the same side of the magazine frame, and across the frame. The claims from which these claims depend, by contrast, recite only transfer across the frame. For example, independent claim 5 recites an across-frame transfer where the active package is on the first removable cartridge, the ready package is on the second removable cartridge, and the “trailing end of said stranded material carried by said active package is connected to a leading end of said stranded material carried by said ready package” (on the “opposite side[]” of the frame). Claims 6 and 7, which depend from claim 5, add the feature of same-side transfer. Claim 6 recites an “additional ready package on said first removable cartridge, to be selectively interposed between said active package and said ready package.” Claim 7 similarly recites an “additional ready package on said second removable cartridge to be selectively interposed between said active package . . . and said ready package.”

ACS provides, on page 15 of its Patent Owner Response, the following annotated version of Figure 12 of the '360 patent to illustrate how the claimed transfers work.

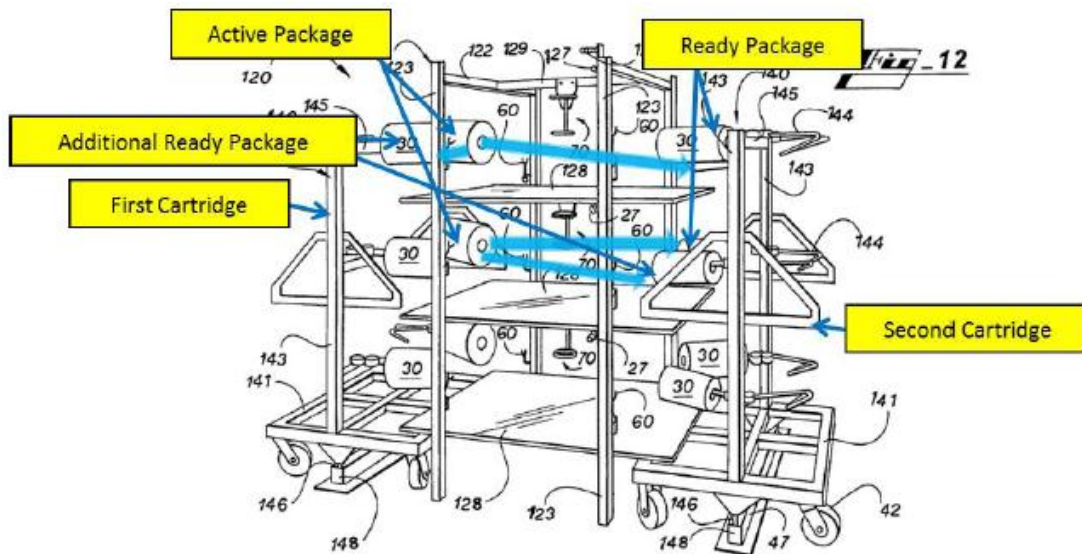

In the annotated Figure 12 above, the top level depicts the additional ready package on the first cartridge interposed between the active package and ready package (claim 6), and the middle level depicts the additional ready package on the second cartridge interposed between the active package and ready package (claim 7). ACS's annotated figure above accurately reflects the same-side and across-frame transfers recited in claims 6 and 7. Claims 13, 15–18, and 21 also recite both types of transfer, via “interpos[ing]” or “interconnecting” an additional package on one or both sides of the frame.⁷

Turning to the allegations in Shaw's Petition, Shaw relies on Münnekehoff as teaching all of the limitations of the claims from which claims 6, 7, 13, 15–18, and 21 depend. *See* -132 Pet. 9–16. As shown in Figure 2 above, Münnekehoff has one stock bobbin and one standby bobbin

⁷ Although we refer primarily to the language of claims 6 and 7 for convenience, our analysis applies equally to claims 13, 15–18, and 21.

at each level, on either side of the frame. The tail end of the stock bobbin is connected to the lead end of the standby bobbin to allow for “continuous operation.” Ex. 1005, p. 5, ll. 21–28. ACS does not dispute that Münnekehoff teaches all of the limitations of the parent claims of claims 6, 7, 13, 15–18, and 21, including the across-frame transfer.

What Münnekehoff lacks, however, is the same-side transfer from one bobbin to another on one side of the frame. Shaw relies on Ligon as teaching this limitation. Shaw contends that Münnekehoff’s single bobbin on either side of the frame could be replaced with a pair of bobbins, as taught by Ligon, which would allow “runtime per side [to be] lengthened.” -132 Pet. 18–21. Dr. Wang testifies in his declaration filed with Shaw’s Petition that the package arrangement in Münnekehoff “lends itself to the interposing arrangement” of Ligon for same-side transfers prior to across-frame transfers, and cites the Specification of the ’360 patent for the proposition that “the tying together of neighboring packages to obtain longer, continuous run time is well-known and widely used in the industry.” Ex. 1001 ¶ 32 (citing Ex. 1002, col. 1, l. 66–col. 2, l. 3; col. 6, ll. 52–55). Dr. Wang further testifies as follows:

[C]onsistent with the widespread and longtime use of tying together neighboring packages, modifying the creel structures to accommodate additional pegs and associated packages to creels is commonly used in the industry to achieve manufacturer needs, as well as product specifications and utilized materials. Applying common sense, a person of ordinary skill in the art would have replaced one of the bobbins in Munnekehoff with a pair of bobbins as in Ligon [] to obtain predictable desired results, such as longer, continuous run time between transfers. This change would have been motivated by numerous manufacturing benefits, for example, the doubling of runtime for each removable section before it has to be replaced.

Id. ¶ 33.

Based on our review of Shaw’s contentions and supporting evidence, as well as ACS’s arguments in response, we are not persuaded that claims 6, 7, 13, 15–18, and 21 would have been obvious based on the combination of Münnekehoff and Ligon for two reasons.

i. Operability of Münnekehoff-Ligon Combination

First, merely adding a second bobbin to each side of the frame in Münnekehoff, as Shaw proposes in the Petition, would result in an inoperable assembly. ACS correctly points out in its Patent Owner Response that because the Münnekehoff assembly has structures in the middle of the assembly between the two cartridges, “[a]fter a single rotation of packages, the guide tubes would become ensnared and the process would have to stop.” -132 PO Resp. 30–32. According to ACS, “[t]he only way this could be avoided is to completely redesign Münnekehoff so that the strands no longer travel upward [in the thread guiding tubes] through the next level.” *Id.* at 30. We agree.

Münnekehoff describes an assembly with multiple levels, and a bobbin on either side of the frame at each level. Figure 2 of Münnekehoff shows column 20 with thread guiding tubes 21 between stock section 8 and standby section 9. Figure 4 shows a thread guiding tube for each level. If Münnekehoff had two bobbins on either side rather than one, as Shaw proposes, thread would be pulled in a circular manner (same-side, then across the frame, then same-side, then across the frame again). Doing so would cause the yarn to wrap around the middle column and yarn guiding tubes after the first rotation.

ACS's position is supported by the testimony of Mr. Chadwick, who explains how the thread would be ensnared and provides the following annotated version of Figure 4.

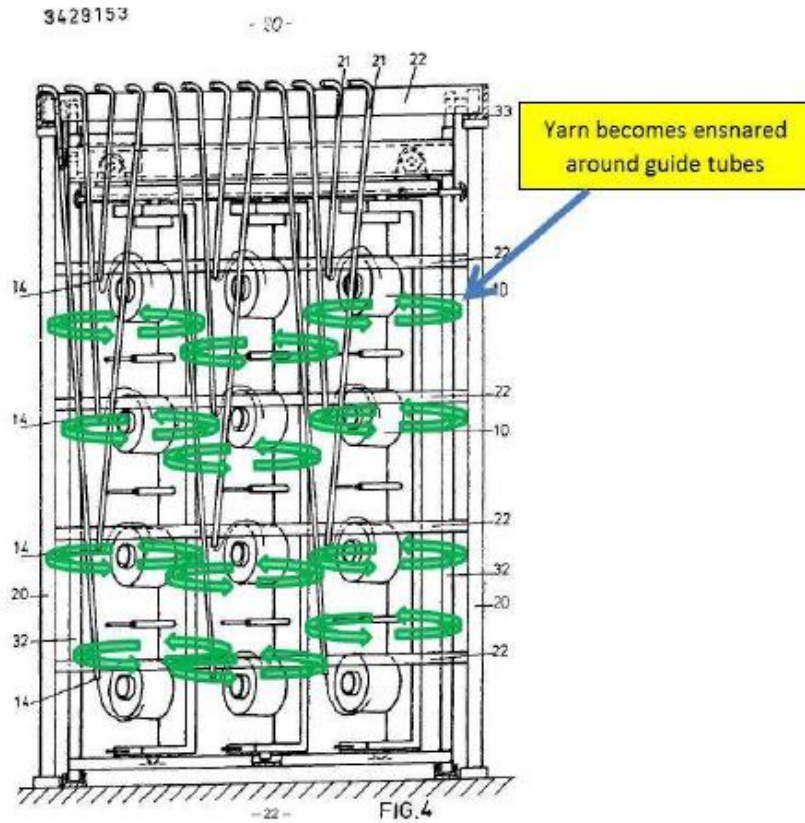

Ex. 2001 ¶ 59. The annotated Figure 4 above shows how thread would be pulled in a circular manner from one package to the next and become tangled around the thread guiding tubes. Further, although only illustrative, ACS provided at the hearing a sequence of demonstrative exhibits showing the rotation and how the tangling would occur. *See* Ex. 2005 at 8–17; Tr. 50:1–56:17. ACS also correctly argues that Münnekehoff uses holding rods 19 to hold the thread on either side of the frame, and Shaw provides no explanation in the Petition as to how such an arrangement would be modified to account for multiple bobbins on either side, as allegedly taught by Ligon. *See* -132 PO Resp. 25–27; Ex. 2001 ¶ 56.

ACS's argument that Shaw's proposed modification to the Münnekehoff assembly would not work (absent major changes to the assembly to prevent the tangling) is persuasive. "If references taken in combination would produce a 'seemingly inoperative device,' . . . such references teach away from the combination and thus cannot serve as predicates for a prima facie case of obviousness." *McGinley v. Franklin Sports, Inc.*, 262 F.3d 1339, 1354 (Fed. Cir. 2001) (citation omitted); *see also In re ICON Health & Fitness, Inc.*, 496 F.3d 1374, 1382 (Fed. Cir. 2007) ("a reference teaches away from a combination when using it in that combination would produce an inoperative result," but the obviousness analysis must account for "modifications that one skilled in the art would make to a device borrowed from the prior art"); *In re Gordon*, 733 F.2d 900, 902 (Fed. Cir. 1984) (finding no reason to modify a prior art device where the modification would render the device "inoperable for its intended purpose").

We agree that a person of ordinary skill in the art would not have been led to make the proposed change to Münnekehoff—adding a second bobbin to each side—due to the tangling that would result from the change. Further, although Shaw is correct that overall "runtime" (i.e., the time when thread may be pulled without having to replace packages) would be increased by adding a second bobbin to each side, *see* -132 Pet. 19, we do not agree that a skilled artisan would have had adequate reason to combine the references due to the inoperability of the modified assembly. For similar reasons, we are not persuaded by Dr. Wang's testimony that the combination of Münnekehoff and Ligon would have been "common sense" and would have achieved "predictable desired results." *See* Ex. 1001 ¶ 33. Because the

proposed combination would be inoperable, Shaw’s analysis does not amount to “articulated reasoning with some rational underpinning to support the legal conclusion of obviousness.” *See KSR Int’l Co. v. Teleflex Inc.*, 550 U.S. 398, 418 (2007) (quotations and citation omitted).

In its Reply, Shaw argues that it was within the skill set of a person of ordinary skill in the art to “select/adjust yarn paths in a manner that avoids ensnarement.” -132 Reply 14. As support, Shaw cites a reply declaration from Dr. Wang describing two possible ways in which ensnarement allegedly could be avoided. Ex. 1013 ¶¶ 28–30. Dr. Wang provides the following diagrams.

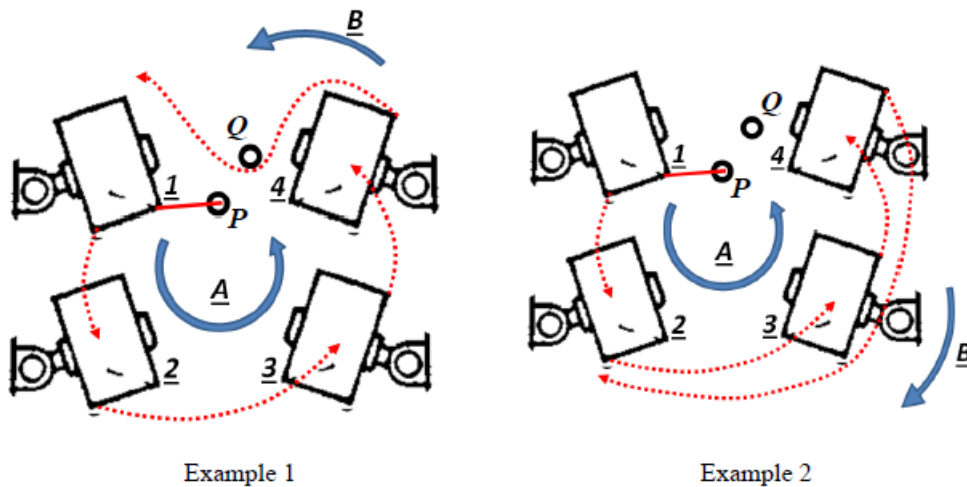

Id. ¶ 28. Example 1 above involves adding a tube Q to the assembly to prevent ensnarement after the first rotation A, and Example 2 involves reversing the sequence of packages after the first rotation A. *Id.*

None of the analysis in Dr. Wang’s reply declaration, however, was included with Shaw’s Petition. *See* 37 C.F.R. § 42.23(b); Rules of Practice for Trials Before the Patent Trial and Appeal Board and Judicial Review of Patent Trial and Appeal Board Decisions; Final Rule, 77 Fed. Reg. 48,612, 48,620 (Aug. 14, 2012) (“Oppositions and replies may rely upon appropriate

evidence to support the positions asserted. Reply evidence, however, must be responsive and not merely new evidence that could have been presented earlier to support the movant's motion.”); Office Patent Trial Practice Guide, 77 Fed. Reg. 48,756, 48,767 (Aug. 14, 2012) (“While replies can help crystalize issues for decision, a reply that raises a new issue or belatedly presents evidence will not be considered and may be returned. . . . Examples of indications that a new issue has been raised in a reply include new evidence necessary to make out a *prima facie* case for the patentability or unpatentability of an original or proposed substitute claim, and new evidence that could have been presented in a prior filing.”). The modification to Münnekehoff proposed in the Petition was only to add a second bobbin on either side of the frame, *see* -132 Pet. 18–21, but Dr. Wang now proposes making different changes to allow Münnekehoff to be combined with Ligon. During the hearing, Shaw acknowledged that Ligon's teaching of two bobbins on one side of the frame could not just be inserted into the Münnekehoff assembly, and that some changes would be necessary to combine the two references. Tr. 17:14–20. Shaw does not provide any reason, however, as to why the changes proposed in its Reply could not have been discussed earlier in the Petition.

Even if Dr. Wang's new analysis had been included in the Petition, though, we do not find it persuasive. The use of tube Q, shown in the diagrams above, is not disclosed in the cited references. Dr. Wang does not provide any basis (in Ligon or otherwise) for adding the additional tube to the Münnekehoff assembly in the manner proposed, or cite anything in the references indicating that the rotation of packages should be reversed after one sequence. Indeed, the opposite appears to be the case. Because the

packages on one side of the frame would be replenished while thread is being pulled from the packages on the other side, a person of ordinary skill would not want to reverse the rotation and immediately begin pulling thread from a recently depleted package. *See* Ex. 1005, p. 5, ll. 26–28; p. 6, ll. 7–9; p. 7, ll. 12–15.

Shaw also argues in its Reply that no entanglement would occur in a system with only one level, and that Münnekehoff “contemplates reconfiguring the packages.” -132 Reply 14–15 (citing Ex. 1013 ¶ 26; Ex. 1005, p. 6, l. 34–p. 7, l. 2). Every embodiment described in Münnekehoff, however, has multiple levels, and the Münnekehoff assembly also includes a column for the thread guiding tubes between the cartridges on either side, which would cause entanglement in the middle of the assembly as well. Further, the portion of Münnekehoff cited by Shaw only describes reconfiguring the pegs for holding the bobbins, not reconfiguring the number of bobbins, the sequence of bobbins from which thread is pulled, or the way in which thread is pulled from the bobbins. *See* Ex. 1005, p. 6, l. 34–p. 7, l. 2.

Finally, Shaw contends that Mr. Chadwick’s testimony should be given little weight because he is the named inventor on the ’360 patent and the president and sole owner of ACS, and because Mr. Chadwick’s testimony regarding “interposing” conflicts with prior testimony he gave in the related district court action between the parties, *Automated Creel Systems, Inc. v. Shaw Industries Group, Inc.*, N.D. Ga. Case No. 1:12-cv-00424-RWS. -132 Reply 2–3 (citing Ex. 1015 at 172:4–11). We have taken into account Mr. Chadwick’s connection with ACS in evaluating ACS’s arguments, and conclude that his testimony provides some support

for the logical entanglement argument made by ACS in its Patent Owner Response. Further, we rely on our own analysis of the “interposing” language of the claims, as set forth above, and do not observe any conflict between Mr. Chadwick’s previous testimony (regarding claim 6 of the ’360 patent) and his testimony regarding entanglement in the Münnekehoff system if combined with Ligon.

ii. Reasons to Combine Münnekehoff and Ligon

Second, a person of ordinary skill in the art would not have been motivated to combine Münnekehoff with Ligon because Münnekehoff uses multiple sharp turns in guiding thread from the bobbins, and Ligon discourages the use of sharp turns. *See* -132 PO Resp. 17–21. As shown in Figure 2 of Münnekehoff, thread from a package enters balloon thread guide 14 horizontally, undergoes a 90-degree turn to vertical through thread guiding tube 21, then again undergoes a 90-degree turn at the top of thread guiding tube 21 to horizontal. *Ex. 1005*, p. 11, ll. 26–32. Ligon discloses that sharp changes in direction for yarn packages are “a problem to which considerable attention may be given.” *Ex. 1010*, col. 1, ll. 46–50. Specifically, “[e]ach time that the yarn changes its direction, *particularly sharply*, the chances of a yarn break are greatly increased because of the increased tension resulting from *increased angles*.” *Id.* at col. 1, ll. 32–38 (emphasis added). Thus, Ligon’s assembly uses a “relatively straight in-line yarn delivery path in which yarn bends and changes in direction are minimized.” *Id.* at col. 1, ll. 4–10; col. 1, ll. 55–58; col. 2, ll. 5–8 (“a generally in-line yarn delivery path”); col. 2, ll. 23–26 (“reduced bends in the yarn delivery path”).

The “in-line” yarn delivery path in Ligon is shown in Figure 1 below.

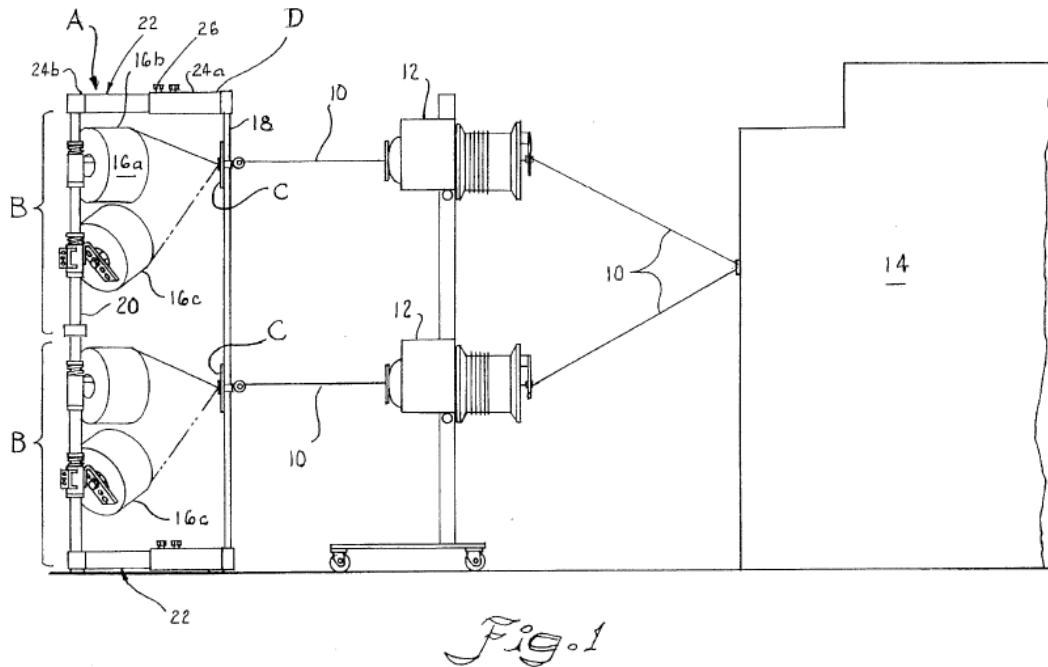

Figure 1 depicts thread being guided through yarn eyelet assembly C and yarn accumulator 12 in a generally horizontal manner, at angles greater than 90 degrees. *See id.* at col. 3, ll. 55–63. ACS contends that a person of ordinary skill in the art would not have thought to combine Münnekehoff and Ligon due to Münnekehoff’s use of 90-degree turns and Ligon’s express teaching that sharp turns should be avoided. -132 PO Resp. 17–21. Again, ACS’s arguments are supported by Mr. Chadwick’s explanation of the references, and we find them persuasive. *See Ex. 2001* ¶¶ 38–47.

Shaw responds that ACS ignores the “similarity in yarn bends” between Münnekehoff and Ligon, pointing out that Figure 1 of Ligon and Figure 2 of Münnekehoff both show three turns in the yarn path. -132 Reply 5–7. As described in Ligon, however, it is the “increased angles” of “particularly sharp[]” turns that are of concern, not necessarily the number of turns overall. *See Ex. 1010*, col. 1, ll. 32–38.

Shaw also argues, citing Dr. Wang's reply declaration, that the angle between yarn package 16c and yarn eyelet assembly C in Figure 1 of Ligon "approaches 90 degrees," and Ligon "contemplates sharper turns by moving the front frame 18 toward the rear frame 20 . . . to accommodate weak yarn, which would, consequently, result in a sharper turn" at that angle. -132 Reply 8 (citing Ex. 1010, col. 5, ll. 24–30; Ex. 1013 ¶ 18). Shaw's arguments are not persuasive. As shown in Figure 1 of Ligon above, the angle at issue appears to be closer to 135 degrees than 90 degrees. Further, Ligon discloses that as front frame section 18 is moved toward rear frame section 20, it is "necessary" to adjust lower yarn packages 16c and 16d by moving lower adjustable mounts 32 and yarn holders 28c. Ex. 1010, col. 5, ll. 24–43. Thus, although Shaw is correct that front frame section 18 may be moved toward rear frame section 20 in Ligon (which would otherwise decrease the angle between yarn package 16c and yarn eyelet assembly C), Shaw does not account for the fact that a corresponding adjustment would be made in the level of yarn package 16c.

Finally, Shaw contends that even if Ligon's desire for an "in-line" yarn delivery path was inconsistent with the 90-degree turns in Münnekehoff, a person of ordinary skill in the art would be motivated to combine the references because Ligon discloses other "aspects," such as being able to switch between a two-package and four-package arrangement, and objectives other than minimizing yarn breakage through "in-line" delivery. -132 Reply 8–10. None of these arguments, however, disproves the fact that Ligon expressly discourages the type of sharp turns that are present in Münnekehoff, or shows that a skilled artisan would have disregarded that inconsistency in assessing the references. We also disagree

with Shaw's reading of Ligon. Throughout its description of the "Background of the Invention," Ligon describes as its primary objective minimizing sharp changes in direction with an "in-line" path to prevent the yarn from breaking. *See* Ex. 1010, col. 1, l. 4–col. 2, l. 2. Using 90-degree turns, as in Münnekehoff, is inconsistent with that goal.

Therefore, we are not persuaded that a person of ordinary skill in the art would have looked to Ligon to modify the assembly of Münnekehoff.

3. Ground Based on Barmag and Ligon

a. Barmag

Barmag discloses a "feeding bobbin creel for textile machines" that provides "continuous thread take-off" through the use of both active and "reserve" bobbins. Ex. 1007 ¶¶ 1–2. Specifically, "the yarn end wound up in a yarn reserve of a presented bobbin is connected to the beginning of the thread of the reserve bobbin that is also mounted on the warping creel" and, "[a]fter the presented bobbin is unwound and now the reserve bobbin is presented, the bobbin that became empty is replaced with a full bobbin, which then serves as a reserve bobbin." *Id.* ¶ 2.

Figure 1 of Barmag is reproduced below.

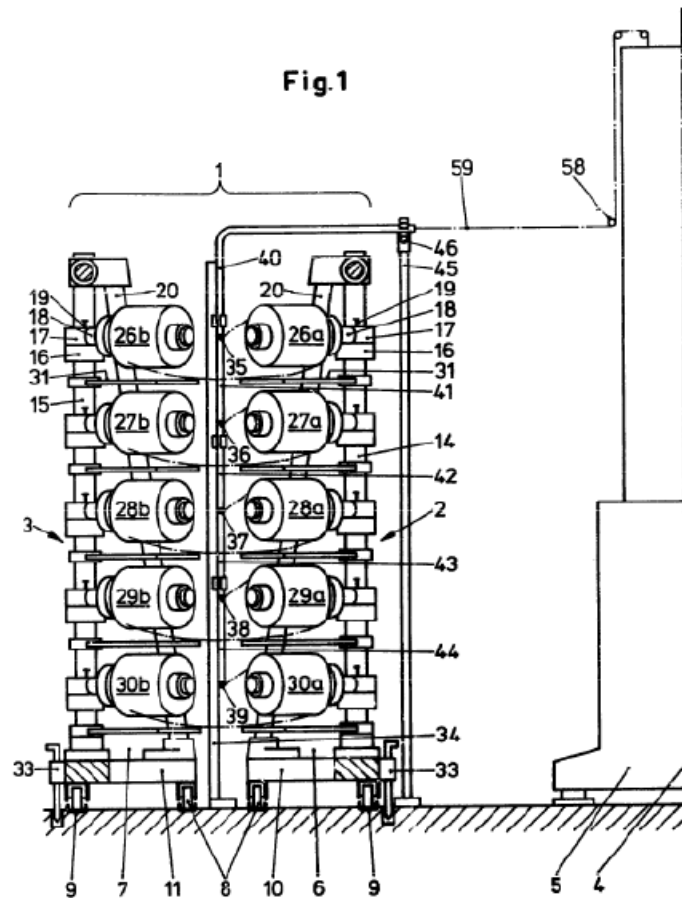

Figure 1 depicts a creel arrangement comprising arbors 18 for holding bobbins, creel carriage 6 with active bobbins 26a–30a, and creel carriage 7 with reserve bobbins 26b–30b. *Id.* ¶¶ 13–14. The arrangement also includes thread guide support 34 with a “thread guide for each pair of co-operating bobbins” (e.g., thread guide 35 for bobbins 26a and 26b). *Id.* ¶ 15. In the embodiment shown in Figure 1, the thread guides are “inlet openings” of thread guide tubes 40–44, which guide the thread coming from the bobbins. *Id.* Barmag also discloses that “thread guide eyelets” can be used instead of thread guide tubes, and in that scenario, thread guide eyelets would be positioned in the “deflection points of the thread path and on the cross

member 46 of the support frame 45, 46.” *Id.* Creel carriages 6/7 also have wheels 8 for moving on rails 9 on the floor of a facility. *Id.* ¶¶ 13–14.

b. Analysis

The creel arrangement disclosed in Barmag is very similar to the one disclosed in Münnekehoff. Both references disclose packages on multiple levels, with one package on either side of the frame at each level, and both references disclose multiple 90-degree turns in the tubes that guide the thread. The parties’ arguments regarding Barmag in combination with Ligon, as well as the testimony of Dr. Wang and Mr. Chadwick, are nearly identical to the arguments and testimony regarding Münnekehoff and Ligon. *See* -132 Pet. 33–36; -132 PO Resp. 37–55; -132 Reply 15.

For similar reasons to those set forth above, we agree with ACS that Shaw’s proposed modification of adding a second bobbin to either side of the frame in Barmag would, absent a significant redesign, result in entanglement around thread guide support 34 and thread guide tubes 40–44. *See supra* Section II.C.2.c.i; -132 PO Resp. 47–48, 50–54. We also agree with ACS that such entanglement would occur even if Barmag used “thread guide eyelets” (rather than tubes) because the eyelets still must be supported by thread guide support 34 in the middle of the frame, and the thread would wrap around that support. *See* -132 PO Resp. 47–48, 50–54; Tr. 51:1–13; Ex. 1007 ¶¶ 15, 20 (“All thread guide tubes associated with a single warping creel unit are fixed to the thread guide carrier 34 that is anchored in a fixed position in the floor of the machine hall.”). Further, Barmag’s use of 90-degree turns conflicts with Ligon’s teaching that sharp turns should be avoided. *See supra* Section II.C.2.c.ii; -132 PO Resp. 41–45. Therefore, we

are not persuaded that a person of ordinary skill in the art would have been led to combine Barmag with Ligon, as Shaw contends.

4. Conclusion

Upon review of all of the evidence, we are not persuaded that a person of ordinary skill in the art would have been led to combine the teachings of Münnekehoff or Barmag with Ligon to achieve the claimed assemblies and methods, which require both same-side and across-frame thread transfers. Shaw has not shown, by a preponderance of the evidence, that claims 6, 7, 13, 15–18, and 21 would have been obvious over Münnekehoff and Ligon, or over Barmag and Ligon.

D. Claim 4

Shaw argues in its Petition in Case IPR2013-00584 that claim 4 is unpatentable under 35 U.S.C. § 103(a) based on two combinations of references: (1) Münnekehoff and Bluhm, and (2) Barmag and Bluhm. -584 Pet. 27–31, 39–42. Shaw again relies on the testimony of Dr. Wang in support. *Id.* (citing Ex. 1101 ¶¶ 38–44, 58–62). We have reviewed Shaw’s Petition, ACS’s Patent Owner Response, and Shaw’s Reply, as well as the evidence discussed in each of those papers. We are persuaded, by a preponderance of the evidence, that claim 4 is unpatentable based on both asserted grounds.

1. Ground Based on Münnekehoff and Bluhm

a. Bluhm

Bluhm⁸ discloses a “compact yarn supply creel adapted to support unusually large diameter yarn supply packages for continuous feeding of yarn to a textile yarn processing machine.” Ex. 1111, col. 1, ll. 6–15. Yarn supply packages are supported on rotary frames of the creel in pairs, with each pair including “a feed package and a reserve package tailed together.” *Id.* at col. 2, ll. 59–64. The paired packages face inward toward a “yarn guide,” which “guid[es] the yarn as it is withdrawn from the yarn supply packages and direct[s] the yarn to the textile machine.” *Id.* at col. 3, ll. 22–31.

⁸ The assignee listed on the Bluhm reference is American Barmag Corporation. Ex. 1111. The applicant listed on the Münnekehoff and Barmag references is Barmag Barmer Maschinenfabrik AG. Exs. 1005, 1007.

Figure 3 of Bluhm is reproduced below.

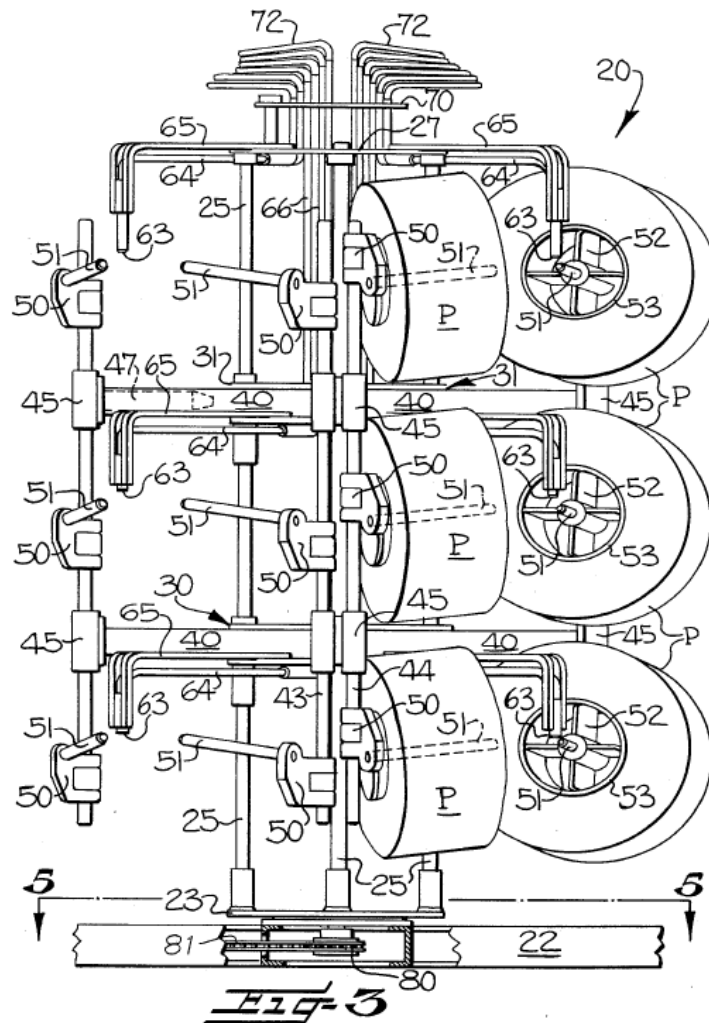

Figure 3 depicts yarn support frame 20 with yarn supply packages P installed on yarn support spindles 51 that extend outwardly from yarn support posts 43 and 44. *Id.* at col. 6, ll. 3–18. As shown in Figure 3, yarn withdrawn from an active package enters yarn guide eye 63 of yarn feed tube 64 and travels vertically through yarn feed tube 64, horizontally through yarn feed tube 64, vertically through yarn feed tube 66, and horizontally through yarn feed tube 72 before finally reaching the textile machine. *Id.* at col. 6, l. 66–col. 7, l. 24. Yarn guide eye 63 is “positioned at

the apex of the longitudinal axes 60, 61 [shown in Figure 4] of the paired yarn supply packages.” *Id.* at col. 6, ll. 60–65.

b. Analysis

Shaw relies on Münnekehoff as teaching all of the limitations of claims 1, 2, and 3, from which claim 4 depends. *See* -584 Pet. 17–20, 27–31. ACS does not dispute that Münnekehoff teaches all of the limitations of claims 1, 2, and 3.

Claim 4 recites the additional limitation that “said annular turning surface and said upper turning surface are separated by a distance corresponding to the diameter of said packages.” We interpret the phrase “distance corresponding to the diameter of said packages” to mean a distance that is derived from the diameter of a fully loaded package. *See supra* Section II.A. Münnekehoff does not teach the distance limitation because the distance separating balloon thread guides 14 (the “annular turning surface”) and the 90-degree turn in thread guiding tubes 21 shown at the top of Figure 2 (the “upper turning surface”) greatly exceeds, and is not derived from, the diameter of a fully loaded package. This was the reason *inter partes* review was denied as to claim 4 in Case IPR2013-00132. *See* -132 Dec. on Inst. 23–25.

Shaw, therefore, relies on Bluhm as teaching the recited distance. -584 Pet. 27–31. According to Shaw, Figure 3 of Bluhm depicts yarn guide eye 63 as “generally aligned with the center axis of the package” and the horizontal portion of yarn feed tube 64 as “slightly elevated above the outer diameter of a fully loaded package.” *Id.* at 28–29. In support of its

package is further driven by Bluhm's stated desire to minimize the overall size/height of the creel such that it is just large enough to receive the large diameter packages. To maintain the small size (and height) of the creel while utilizing the guiding means of Bluhm would require this distance to be minimized relative to the fully loaded package, and thus, to be derived from the diameter of a fully loaded package.

Ex. 1101 ¶ 39 (citations omitted).

Shaw also argues that Bluhm teaches the distance limitation of claim 4 because it discloses adjustability of the creel components. -584 Pet. 29–31. For instance, as shown in Figures 3 and 6 of Bluhm, yarn guide eye 63 is positioned at the “apex” of the axis of a corresponding package, and support plate means 30/31 (from which support arm 40 and yarn support spindle 51 extend) may be adjusted vertically. *See id.*; Ex. 1101 ¶ 40. Thus, according to Dr. Wang, “the space between each level can be adjusted and . . . the position of each yarn guide (63) can be adjusted to maintain the axial relationship with the package.” Ex. 1101 ¶ 41. Dr. Wang testifies that the distance between yarn guide eye 63 and the point where yarn feed tube 64 turns from vertical to horizontal “necessarily corresponds to the diameter of a fully loaded package since this distance needs to vary depending on the particular size of the package installed and the resulting spacing between the vertically spaced levels.” *Id.*

As to the reasons why a person of ordinary skill in the art would have combined the turning surfaces disclosed in Bluhm with the assembly of Münnekehoff, Dr. Wang testifies as follows:

First, such alteration, substitution or combinations of guides with creels is commonly used in the industry to achieve manufacturer needs, as well as the product specifications and utilized materials. Applying common sense, a person of ordinary skill in the art would combine guide means of the type

disclosed in Bluhm with Munnekehoff's creel structure using well-known methods to obtain predictable desired results, such as enhanced adjustability or an altered overall creel footprint. Indeed, it is customary in the industry for vendors to offer an array of guide options marketed as individual components. In other words, such a combination is a substitution of one known, equivalent element (*i.e.*, tube guides) for another (*i.e.*, tube guides with telescoping sections).

Second, a person of ordinary skill would be able to readily combine guide means of Bluhm with the creel structure of Munnekehoff. For example, both the guide means of Bluhm and the guide (21) of Munnekehoff are tube-like structures. Accordingly, a person of ordinary skill could substitute the guide tube of Munnekehoff with the guide means of Bluhm to include guide tubes that are adjustably supported by support rods. This change would be motivated, for example, by the need to provide adjustability in the distance between bobbins and thread guides in Munnekehoff. (*See* Munnekehoff at claim 13)

Id. ¶¶ 43–44.

Shaw's analysis, supported by the testimony of Dr. Wang, is persuasive. Bluhm teaches an annular turning surface (*i.e.*, yarn guide eye 63) generally aligned with the spindle supporting the corresponding package and an upper turning surface (*i.e.*, the point where yarn feed tube 64 turns from vertical to horizontal) generally aligned with the outer diameter of a fully loaded package, such that the distance between the two is approximately the radius of a fully loaded package. Importantly, this is identical to the exemplary embodiment in the Specification of the '360 patent, which describes "distance *h*" as the radius of a fully loaded package:

Best results may be achieved where turning surfaces 73 and 74 are separated from one another by a *distance h corresponding to the diameter of the stranded material package 30*, such that the plane of the lower annular turning surface 73 is *generally*

aligned with, and preferably slightly elevated from the center axis of the package 30, or the support arm 144. The upper turning surface 74 is positioned so that it is generally aligned with, and more preferably, slightly elevated above the outer diameter of a fully loaded package 30 so as to provide clearance between ballooning around package 30 and the running length of material as it is routed to the secondary guides 127.

See Ex. 1002, col. 9, ll. 27–38 (emphasis added); Fig. 19B. The radius embodiment in Figure 19B of the '360 patent is the only embodiment the Specification references as having a distance “corresponding” to the diameter of the package. The phrase “distance corresponding to the diameter of said packages,” as used in claim 4, is very broad and encompasses, at minimum, the sole exemplary embodiment described in the Specification that has a distance of approximately the radius of a fully loaded package. See -132 Dec. on Inst. 13–15.

Further, based on Bluhm’s teaching of the adjustability of the creel components to ensure the correct spacing of packages within the creel, and Dr. Wang’s analysis of the same, we are persuaded, by a preponderance of the evidence, that the distance between turning surfaces in Bluhm is derived from the diameter of a fully loaded package, and that a person of ordinary skill in the art would have had reason to incorporate Bluhm’s distance between turning surfaces into Münnekehoff.

In its Patent Owner Response, ACS argues that Bluhm does not teach the distance limitation of claim 4 and that a person of ordinary skill in the art would not have combined Münnekehoff and Bluhm to achieve the creel magazine of claim 4. We have reviewed all of the arguments made by ACS in its Patent Owner Response, and the evidence cited in support, but do not find them persuasive.

First, ACS argues that only the top row in Bluhm has a distance between yarn guide eye 63 and the horizontal portion of yarn feed tube 64 that is approximately the radius of a loaded package, and in the two lower rows, the horizontal portion is below the top of the loaded package. -584 PO Resp. 11–14. Thus, according to ACS and its declarant, Dr. Brookstein,⁹ the distance between turning surfaces is “arbitrary” and not derived from the diameter of a fully loaded package. *Id.* (citing Ex. 2102 ¶¶ 38–40). Claim 4, however, does not require multiple levels, each with the same “distance corresponding to the diameter of said packages.” Shaw relies on the single distance shown in the top row of Bluhm (i.e., approximately the radius of a fully loaded package), and proposes a modification to the assembly of Münnekehoff to use that distance. -584 Pet. 27–31. Whether other disclosures in Bluhm also teach the same distance is immaterial.

Second, ACS asserts that the distance between turning surfaces in Bluhm is not derived from the diameter of a fully loaded package because the upper turning surfaces are “between,” not “over,” the packages and “do not have a need to clear the height of the packages P.” -584 PO Resp. 14–15 (citing Ex. 2012 ¶¶ 20, 40). We do not find this argument persuasive. Bluhm discloses that the package support spindles are “movable outwardly to a loading position where they extend outwardly from the rotary frame *to facilitate removing* the empty yarn supply package support and *replacing the*

⁹ ACS states in its Patent Owner Response that certain portions of the Decision on Institution and Dr. Brookstein’s testimony are “incorporated herein by reference.” -584 PO Resp. 6–7, 44. Doing so was improper, and we consider Dr. Brookstein’s testimony only to the extent ACS specifically refers to it in the Patent Owner Response. *See* 37 C.F.R. § 42.6(a)(3) (“Arguments must not be incorporated by reference from one document into another document.”).

same with a full yarn supply package.” Ex. 1111, col. 3, ll. 17–22 (emphasis added). Dr. Wang provides the following annotated version of a portion of Figure 4 of Bluhm to show how that motion would occur.

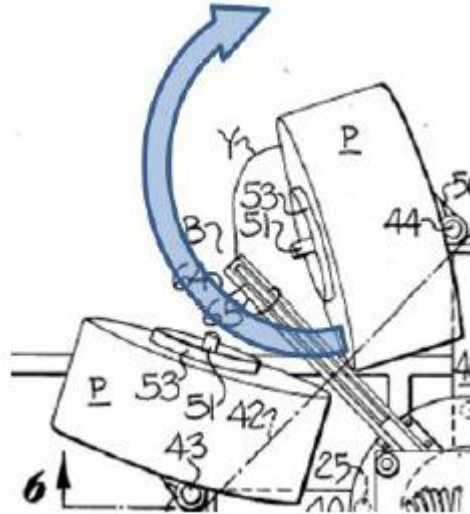

Ex. 1116 ¶ 14; *see also* Ex. 2301 at 147:10–149:5 (testimony of Dr. Wang regarding how the motion would occur). As shown in the annotated figure above, in order for the assembly to swing out so that the packages can be replenished, the horizontal portion of yarn feed tube 64 would need to be above the height of the packages. This is also shown in the top row of the assembly in Figure 3 of Bluhm. We agree with Dr. Wang’s reading of the reference.

Third, ACS disputes Dr. Wang’s testimony regarding adjustability of the assembly in Bluhm, and argues that the height of the horizontal portion of yarn feed tube 64 is not adjustable. -584 PO Resp. 15–18 (citing Ex. 2102 ¶¶ 58–60). We first note that adjustability is not required by claim 4, but may be considered an indication that the relevant distance is in some sense derived from the diameter of a fully loaded package. Thus, we determine whether Dr. Wang’s opinions on adjustability are correct in light of ACS and Dr. Brookstein’s argument to the contrary.

It is unclear from Bluhm whether yarn feed tube 64 is vertically adjustable. Bluhm discloses that “[t]he inner portions of the horizontal portions of the yarn feed tubes 64 are telescopically connected to the lower ends of vertical yarn feed tubes 66.” Ex. 1111, col. 7, ll. 7–14. Thus, it is clear that yarn feed tube 64 is extendible horizontally via the telescopic connection. Reproduced below is an annotated version of a portion of Figure 3 of Bluhm.

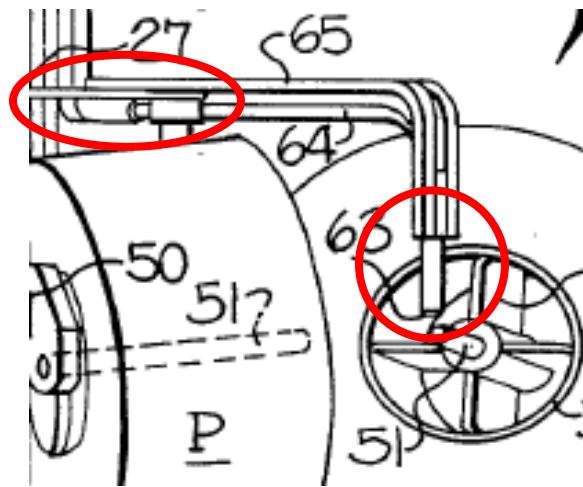

The telescopic connection of yarn feed tube 64 is highlighted in the portion of Figure 3 above. Also highlighted is the vertical portion of yarn feed tube 64, which appears to show a similar telescopic connection for yarn guide eye 63. Figures 2 and 6 of Bluhm show a similar shape. Bluhm discloses that yarn guide eye 63 is “positioned” at the apex of the longitudinal axis of the package, and “supported” in the “lower end of the vertical leg” of yarn feed tube 64. *Id.* at col. 6, l. 60–col. 7, l. 2. Although Bluhm does not disclose expressly that the vertical portion of yarn feed tube 64 is telescopic with respect to yarn guide eye 63, the figures at least suggest that it is and, therefore, that the vertical portion of the tube (from where the yarn enters from the package to the top 90-degree turn) is extendible. Indeed, Figure 3

of Bluhm shows yarn guide eye 63 at different positions with respect to yarn feed tube 64 at each of the three levels, further suggesting that it may be extended up or down to align with the longitudinal axis of the respective package.

Nevertheless, even if yarn feed tube 64 is not vertically extendible, ACS does not dispute that Bluhm discloses vertically adjusting support plate means 30/31, from which yarn support spindles 51 extend, to provide for axial alignment between yarn guide eye 63 and the packages, and to provide for the appropriate spacing between levels. *See* Ex. 1111, col. 5, ll. 22–44; Ex. 1101 ¶¶ 40–41. That adjustability, combined with the fact that the distance shown in Figure 3 of Bluhm is approximately the radius of a fully loaded package (just like in the Specification of the '360 patent), is indicative of the relevant distance in Bluhm being derived from the diameter of a fully loaded package, as Shaw contends.

Fourth, ACS argues that Shaw does not explain sufficiently how the teachings of Münnekehoff and Bluhm would be combined, that the proposed combination would have resulted in an inoperable assembly, and that a person of ordinary skill in the art would not have been motivated to combine the references. -584 PO Resp. 24–39. We have reviewed ACS's arguments and do not find them persuasive. Shaw's contention, as supported by the testimony of Dr. Wang, is that the thread guiding tubes in Münnekehoff could be modified so that the relevant distance (i.e., the distance separating balloon thread guides 14 and the 90-degree turn in thread guiding tubes 21) is approximately the radius of a fully loaded package, as taught by Bluhm, and that a person of ordinary skill in the art would have had reason to do so. *See* -584 Pet. 27–31; Ex. 1101 ¶¶ 38–44 (describing how the modification

would be “using well-known methods to obtain predictable desired results, such as enhanced adjustability or an altered overall creel footprint,” and that the “change would be motivated, for example, by the need to provide adjustability in the distance between bobbins and thread guides in Munnekehoff”); -584 Reply 10–13. We see no reason why that would not be a simple change to the MÜNNEKEHOFF assembly that would work to pull yarn from the various packages, or why Dr. Wang’s alleged reasons, recounted above, as to why a person of ordinary skill in the art would have combined the references are incorrect. Unlike its analysis of claims 6, 7, 13, 15–18, and 21, Shaw has provided sufficient articulated reasoning with rational underpinning to support the legal conclusion of obviousness as to claim 4.

Fifth, ACS argues that Bluhm “teaches against increasing the size of the footprint of a creel,” which would be required by the proposed modifications to MÜNNEKEHOFF. -584 PO Resp. 39–44 (citing Ex. 2102 ¶ 50). As support, ACS cites the disclosure in Bluhm that “the textile yarn processing machines are positioned in a manufacturing plant with a certain spacing therebetween and it is not possible to increase the size of the adjacent yarn supply creels because of the limited floor space.” Ex. 1111, col. 1, ll. 53–57; *see* -584 PO Resp. 40–41. As Shaw points out, however, MÜNNEKEHOFF likewise discloses a need to save floor space and describes one way to do so by pivoting the pegs to allow for the packages to be closer together. -584 Reply 14; *see* Ex. 1005, p. 6, l. 34–p. 7, l. 10; p. 12, ll. 19–27. Thus, the two references are consistent in that regard.

Shaw has shown, by a preponderance of the evidence, that claim 4 would have been obvious over MÜNNEKEHOFF and Bluhm.

2. Ground Based on Barmag and Bluhm

The creel arrangement disclosed in Barmag is very similar to the one disclosed in Münnekehoff, and the parties' arguments and supporting testimony regarding Barmag in combination with Bluhm are nearly identical to the arguments and testimony regarding Münnekehoff and Bluhm. *See* -584 Pet. 39–42; -584 PO Resp. 44–47; -584 Reply 14–15. For similar reasons to those set forth above, we are persuaded that Shaw has shown, by a preponderance of the evidence, that the combination of Barmag and Bluhm is proper and that claim 4 would have been obvious based on the two references. *See supra* Section II.D.1.b; -584 Pet. 39–42 (citing Ex. 1101 ¶¶ 58–62).

3. Conclusion

Based on the record evidence, in light of the arguments presented, Shaw has shown, by a preponderance of the evidence, that claim 4 would have been obvious over Münnekehoff and Bluhm, and over Barmag and Bluhm.

E. Motions to Exclude

The party moving to exclude evidence bears the burden of proof to establish that it is entitled to the relief requested—namely, that the material sought to be excluded is inadmissible under the Federal Rules of Evidence. *See* 37 C.F.R. §§ 42.20(c), 42.62(a). For the reasons discussed below, all of the parties' motions to exclude are denied.

1. Shaw's Motion to Exclude in Case IPR2013-00132

Shaw moves to exclude two portions of Mr. Chadwick's declaration (Exhibit 2001), arguing that Mr. Chadwick is not qualified to offer expert testimony under Federal Rule of Evidence 702. IPR2013-00132, Paper 30. Federal Rule of Evidence 702 provides:

A witness who is qualified as an expert by knowledge, skill, experience, training, or education may testify in the form of an opinion or otherwise if:

(a) the expert's scientific, technical, or other specialized knowledge will help the trier of fact to understand the evidence or to determine a fact in issue;

(b) the testimony is based on sufficient facts or data;

(c) the testimony is the product of reliable principles and methods; and

(d) the expert has reliably applied the principles and methods to the facts of the case.

First, Shaw argues that paragraph 21 of Mr. Chadwick's declaration, stating that Mr. Chadwick "personally know[s]" certain systems like those described in Münnekehoff and Barmag to cause injuries, should be excluded because Mr. Chadwick does not have "expertise in diagnosing medical injuries" and does not provide corroborating evidence for his testimony. *Id.* at 3–4. We do not rely on Mr. Chadwick's testimony in paragraph 21 regarding potential injuries as a basis for our decision regarding the combinations with Ligon and, therefore, deny Shaw's request to exclude paragraph 21 as moot.

Second, Shaw argues that paragraphs 43, 50, 60, 63, and 73 should be excluded because they pertain to patent law and Mr. Chadwick is not an expert in patent law. *Id.* at 4–6. Shaw points to instances where Mr. Chadwick used the term "hindsight" in his testimony, and also instances

where Mr. Chadwick allegedly failed to provide factual support for his opinions. *Id.* Shaw’s arguments are not persuasive. In paragraphs 43, 50, 60, 63, and 73 of his declaration, Mr. Chadwick gives his opinions regarding the teachings of Münnekehoff, Barmag, and Ligon and whether a person of ordinary skill would have thought to combine them in the manner asserted by Shaw. The fact that Mr. Chadwick occasionally used the term “hindsight” does not mean that he was purporting to testify on matters of patent law or that his opinions are otherwise improper. Just as we are able to assess Dr. Wang’s testimony and assign it the appropriate weight, we are able to do so for Mr. Chadwick’s testimony.¹⁰ Shaw’s motion to exclude in Case IPR2013-00132 is denied.

2. ACS’s Motion to Exclude in Case IPR2013-00132

ACS moves to exclude certain portions of Shaw’s Reply and Dr. Wang’s reply declaration (Exhibit 1013) as allegedly “mischaracteriz[ing]” certain testimony of Mr. Chadwick. IPR2013-00132, Paper 32 at 2–6. ACS contends that the materials should be excluded under Federal Rules of Evidence 104(b), 403, or 705, and cites one district court case where the court excluded certain evidence under Federal Rules of Evidence 402 and 403. *Id.* (citing *Advanced Cardiovascular Sys., Inc. v. Medtronic Vascular, Inc.*, 485 F. Supp. 2d 519, 535 (D. Del. 2007)).

¹⁰ ACS, in its opposition to Shaw’s motion to exclude, cites a revised declaration that it purports to have served as supplemental evidence in response to Shaw’s original objection. IPR2013-00132, Paper 35 at 5, 6, 9. The revised declaration is not in the record, however, because ACS did not file a copy with its opposition. Thus, for purposes of deciding the motion to exclude, we refer only to Mr. Chadwick’s declaration filed as Exhibit 2001.

ACS, however, does not explain in any detail why the materials are *inadmissible* under those rules—as opposed to being merely incorrect in ACS’s view. Although ACS certainly disagrees with Shaw’s characterization of the evidence, ACS does not explain sufficiently why or how that is a proper basis to exclude the portions of Shaw’s Reply and Dr. Wang’s reply declaration. ACS’s motion to exclude in Case IPR2013-00132 is denied.

3. Shaw’s Motion to Exclude in Case IPR2013-00584

Shaw moves to exclude two portions of Dr. Brookstein’s declaration (Exhibit 2102). IPR2013-00584, Paper 29. First, Shaw argues that Dr. Brookstein’s opinions in paragraphs 9, 12, 33, 36, and 63 should be excluded under Federal Rule of Evidence 702 because they “lack proper factual support.” *Id.* at 3–4. Second, Shaw argues that paragraphs 11, 12, 17, 23, and 43 of Dr. Brookstein’s declaration relate to features that are not claimed or mentioned in the ’360 patent, and should be excluded as irrelevant under Federal Rule of Evidence 402. *Id.* at 4–6. We have reviewed the cited paragraphs and see no basis on which they would warrant the extreme remedy of exclusion. Shaw’s arguments indicate a mere disagreement with Dr. Brookstein’s testimony and pertain to the weight to be given to that testimony, which we are able to assess without excluding it, as explained above. Shaw’s motion to exclude in Case IPR2013-00584 is denied.

4. ACS's Motion to Exclude in Case IPR2013-00584

ACS moves to exclude certain portions of Dr. Wang's original declaration (Exhibit 1101) and reply declaration (Exhibit 1116) as allegedly not based on sufficient facts or data under Federal Rule of Evidence 702. IPR2013-00584, Paper 32. Again, a mere disagreement with the opposing party as to how evidence should be interpreted or weighed ordinarily does not mean that the evidence should be excluded. We are able to assess the parties' arguments and assign the appropriate weight to all of the declarants' testimony, without excluding any particular portions. ACS's motion to exclude in Case IPR2013-00584 is denied.

F. Motion for Observation

In Case IPR2013-00584, ACS filed a motion for observation (Paper 37) on the cross-examination of Dr. Wang, which took place after Shaw filed its Reply. Shaw filed a response (Paper 40). We have considered ACS's observations and Shaw's responses in rendering our decision.

G. Exhibit 1015

In Case IPR2013-00132, Shaw filed portions of the deposition transcript of Mr. Chadwick from the related district court action between the parties as Exhibit 1015. The transcript as filed contains redacted material and is labeled "Confidential - Attorneys Eyes Only." Neither party, however, filed a motion to seal with the exhibit.

A party intending for a document to be sealed must file a motion to seal with a proposed protective order. *See* 37 C.F.R. §§ 42.14, 42.54(a). Then, if such a motion were to be granted, the protective order would be

entered and would govern the treatment of confidential information in the proceeding. The parties shall confer and file either (1) an unredacted version of Exhibit 1015 to replace the existing version, (2) a confidential, unredacted version (as “Parties and Board Only” in the Patent Review Processing System) with a motion to seal, or (3) a request that Exhibit 1015 be expunged from the record of the proceeding. Any motion to seal must explain the basis for every redaction made and why the redacted material constitutes “confidential information.” *See* 35 U.S.C. §§ 316(a)(1), 316(a)(7); 37 C.F.R. §§ 42.14, 42.54(a); Office Patent Trial Practice Guide, 77 Fed. Reg. 48,756, 48,770 (Aug. 14, 2012) (describing the procedure for filing redacted and unredacted copies of a document). If the parties are unable to reach an agreement on how Exhibit 1015 should be treated, the parties shall file a joint statement setting forth their respective positions.

III. ORDER

Shaw has demonstrated, by a preponderance of the evidence, that:

- (1) claims 1–3, 5, 8–10, 12, 14, 19, and 20 are anticipated by Münnekehoff under 35 U.S.C. § 102(b);
- (2) claims 1–3, 5, 8–10, 12, 14, 19, and 20 are anticipated by Barmag under 35 U.S.C. § 102(b);
- (3) claim 4 is unpatentable over Münnekehoff and Bluhm under 35 U.S.C. § 103(a);
- (4) claim 4 is unpatentable over Barmag and Bluhm under 35 U.S.C. § 103(a);
- (5) claim 11 is unpatentable over Münnekehoff and Miller under 35 U.S.C. § 103(a); and
- (6) claim 11 is unpatentable over Barmag and Miller under 35 U.S.C. § 103(a).

IPR2013-00132 and IPR2013-00584
Patent 7,806,360 B2

Shaw has not demonstrated, by a preponderance of the evidence, that claims 6, 7, 13, 15–18, and 21 are unpatentable over Münnekehoff and Ligon, or that claims 6, 7, 13, 15–18, and 21 are unpatentable over Barmag and Ligon.

In consideration of the foregoing, it is hereby:

ORDERED that claims 1–5, 8–12, 14, 19, and 20 of the '360 patent have been shown to be unpatentable;

FURTHER ORDERED that claims 6, 7, 13, 15–18, and 21 of the '360 patent have not been shown to be unpatentable;

FURTHER ORDERED that the parties' motions to exclude in the instant proceedings are *denied*; and

FURTHER ORDERED that the parties shall file in Case IPR2013-00132, within one week of this decision, an unredacted version of Exhibit 1015 to replace the existing version; a confidential, unredacted version with a motion to seal; a request that the exhibit be expunged; or a joint statement, limited to five pages, setting forth the parties' respective positions.

This is a final decision. Parties to the proceeding seeking judicial review of the decision must comply with the notice and service requirements of 37 C.F.R. § 90.2.

IPR2013-00132 and IPR2013-00584
Patent 7,806,360 B2

PETITIONER:

W. Karl Renner
Hyun Jin In
Thomas Rozylowicz
FISH & RICHARDSON P.C.
axf@fr.com
apsi@fr.com
rozylowicz@fr.com

PATENT OWNER:

Scott Smiley
Mark C. Johnson
THE CONCEPT LAW GROUP
Info@ConceptLaw.com
mjohnson@conceptlaw.com