

UNITED STATES PATENT AND TRADEMARK OFFICE

BEFORE THE PATENT TRIAL AND APPEAL BOARD

ZTE CORPORATION and ZTE (USA) INC.,
Petitioner,

v.

IPR LICENSING, INC.,
Patent Owner.

Case IPR2014-00525
Patent 8,380,244 B2

Before SALLY C. MEDLEY, MIRIAM L. QUINN, and
BEVERLY M. BUNTING, *Administrative Patent Judges*.

BUNTING, *Administrative Patent Judge*.

DECISION ON REMAND

35 U.S.C. § 144 and 37 C.F.R. § 42.5(a)

I. INTRODUCTION

A. Background

ZTE Corporation and ZTE (USA) Inc. (collectively, “Petitioner”) filed a corrected Petition requesting inter partes review of claims 1–8, 14–16, 19–29, 36–38, and 41–44 of U.S. Patent No. 8,380,244 B2 (Ex. 1001, “the ’244 patent”). Paper 9 (“Pet.”).¹ IPR Licensing, Inc. (“Patent Owner”) filed a Patent Owner Preliminary Response (Paper 12 (“Prelim. Resp.”)). Pursuant to 35 U.S.C. § 324, the Board instituted trial on one ground of unpatentability, Claims 1–8, 14–16, 19–29, 36–38, and 41–44 under 35 U.S.C. § 103 as obvious over Jawanda, the GPRS Standards, and the IEEE 802.11 Standard. Paper 19, 22. After institution of trial, Patent Owner filed a Patent Owner Response (Paper 25 (“PO Resp.”)) and Petitioner filed a Reply (Paper 38 (“Pet. Reply”)). Oral hearing was held on May 21, 2015, and a transcript of the hearing is in the record. Paper 47 (“Tr.”). On September 14, 2014, we issued a Final Written Decision holding that Petitioner had demonstrated by a preponderance of the evidence that claims 1–8, 14–16, 19–29, 36–38, and 41–44 of the ’244 patent were unpatentable as obvious based on the instituted ground. Paper 48 (“Final Dec.”).

Patent Owner appealed to the United States Court of Appeals for the Federal Circuit. Paper 49. On April 20, 2017, the Federal Circuit issued a decision affirming our conclusion that the asserted prior art references rendered claims 1–7, 14–16, 19–29, 36–38, and 41–44 obvious, and vacated

¹ We granted the Motion for Joinder filed by Microsoft Corporation, joining Case IPR2015-00074 with this proceeding. Paper 31. Subsequently, Petitioner Microsoft Corporation filed a motion to terminate its participation in this proceeding on May 17, 2017, which we granted May 23, 2017. Paper 53.

and remanded to the Board to consider again our finding of obviousness of claim 8, which depends from claim 1. *IPR Licensing, Inc. v. ZTE Corp., ZTE (USA) Inc., Microsoft Corp.*, 685 F. App'x 933 (Fed. Cir. 2017) (unpublished). In particular, the Federal Circuit agreed with our claim construction for the claim 1 phrase “maintain[ing] a communication session,” but held that “substantial evidence does not support the Board’s articulated motivation to combine the asserted references to arrive at the invention defined in claim 8.” *Id.* at 935, 939. The Federal Circuit’s mandate issued on June 19, 2017.

The Board has reviewed the record in light of the Federal Circuit’s decision. For the reasons that follow, we determine that Petitioner has shown by a preponderance of the evidence that claim 8 of the ’244 patent is unpatentable.

B. Conference Call after Remand

The Board held a conference call on July 18, 2017, with the parties to discuss potential actions to be taken in view of the remand by the Federal Circuit. A court reporter was present on the call, and a transcript of the call was filed by Patent Owner. Ex. 2026. Both parties agreed that additional briefing beyond the arguments and evidence presently in the record was unnecessary, and that the narrow issue to be addressed was the motivation to combine the PDP Context feature of the GPRS Standards that enables the subscriber unit to “maintain a communication session” with a CDMA network as required by claim 8. Paper 54, 2–3. We authorized Petitioner to file a paper containing a numeric listing of citations to the existing record

indicating where the evidence pertaining to this issue was originally introduced or argued in the Petition (*id.* at 3).

C. Related Proceedings

The parties represent that the '244 patent is the subject of the following judicial proceedings: (1) *InterDigital Commc'ns Inc. v. ZTE Corp.*, Case No. 13-cv-00009-RGA (D. Del.), filed January 2, 2013; (2) *InterDigital Commc'ns Inc. v. Nokia Corp.*, Case No. 13-cv-00010-RGA (D. Del.), filed January 2, 2013; and (3) *InterDigital Commc'ns Inc. v. Samsung Elec. Co. Ltd.*, Case No. 13-cv-00011-RGA (D. Del.), filed January 2, 2013. Pet. 2; Paper 6, 2.

D. The '244 Patent (Ex. 1001)

The '244 patent is directed to a system and method of short-range, high-speed, and long-range, lower-speed, data communications using a dual-mode unit. Ex. 1001, Abstract. The wireless communication path is selected based on a request to establish a communication session between first and second sites, by first determining whether the first wireless digital communication path is available. *Id.* at 3:19–22. The first wireless communication path is a wireless LAN connection, and the second wireless communication path is a cellular connection. *Id.* at 3:23–28. The '244 patent describes several embodiments for indicating availability of the first wireless communication mode. *Id.* at 3:44–54. For example, if the first wireless communication path is unavailable, the communication session is established using the second wireless communication path, and “the local wireless transceiver is controlled to make it appear to the second wireless

digital communication path as though the bandwidth were continuously available during the communication session, irrespective of any actual need to transport data communication signals between said first and second sites.” *Id.* at 3:60–4:1.

In another example, the second wireless digital communication path “is provided by establishing a logical connection using a higher layer protocol, such as a network layer protocol” from a subscriber unit to an intended peer node. *Id.* at 4:5–11. The network layer logical connection “is made through a wireless channel that provides a physical layer connection between the portable computer node, through a base station, and the intended peer node.” *Id.* at 4:11–14. The physical layer channel is released, “while maintaining the appearance of a network layer connection to the higher level protocols.” *Id.* at 4:16–18. The ’244 patent contemplates that the physical links “are preferably known wireless communication air interfaces using digital modulation techniques such as [the] Code Division Multiple Access (CDMA) standard [O]ther wireless communication protocols and other types of links 30 may also be used to advantage with the invention.” *Id.* at 5:31–37.

This embodiment is illustrated in Figure 6, reproduced below:

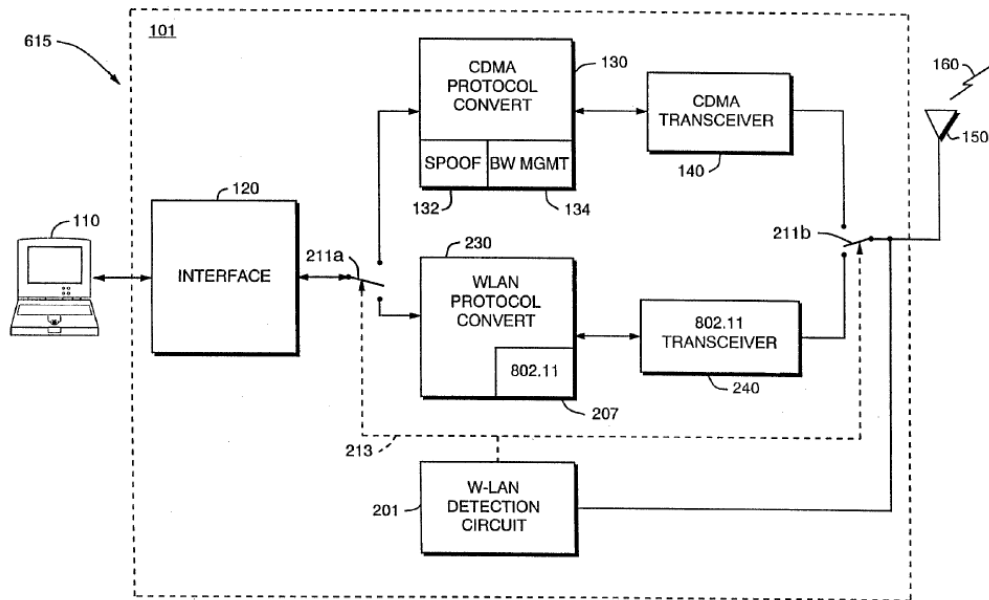

FIG. 6

Figure 6 is a block diagram illustrating the subscriber unit.

Specifically, the subscriber unit 101 connects to a computer 110 via a computer interface 120, to transmit data over the Internet via a first communication route or second communication route. *Id.* at 9:27–57. The interface establishes a connection over the first, faster wireless communication path 213, e.g., wireless local area network (WLAN), if available, using a protocol such as IEEE 802.11. *Id.* at 3:23–27, 8:46–59, 9:40–42. If the WLAN connection is not available, the interface automatically switches to a second, slower, wireless digital long-range communication path, e.g., CDMA. *Id.* at 3:29–50, 9:15–57. When data are being transmitted over the second communication path, the CDMA protocol converter initiates a spoofing function, so that it appears to the terminal equipment that the subscriber unit is connected to the public network at all times. *Id.* at 9:58–63. The bandwidth management function allocates and deallocates CDMA radio channels, and is also responsible for dynamic management of bandwidth allocated to a session by “dynamically allocating

sub-portions of the CDMA radio channels **160**” using a wireless communication protocol. *Id.* at 9:66–10:3. The ’244 patent explains how in the long range, lower data rate mode:

wireless bandwidth is allocated only when there is actual data present from the terminal equipment to the CDMA transceiver [W]hen data is not being presented upon the terminal equipment to the network equipment, the bandwidth management function **134** deallocates initially assigned radio channel bandwidth **160** and makes it available for another transceiver and another subscriber unit **101**.

Id. at 10:34–43.

E. Remanded Claim 8

Claim 8 depends from independent claim 1. Claims 1 and 8 are reproduced below.

1. A subscriber unit comprising:
 - a cellular transceiver configured to communicate with a cellular wireless network via a plurality of assigned physical channels;
 - an IEEE 802.11 transceiver configured to communicate with an IEEE 802.11 wireless local area network; and
 - a processor configured to maintain a communication session with the cellular wireless network in an absence of the plurality of assigned physical channels while the IEEE 802.11 transceiver communicates packet data with the IEEE 802.11 wireless local area network.

8. The subscriber unit of claim 1, wherein the cellular wireless network is a code division multiple access (CDMA) wireless network, and the cellular transceiver is a cellular code division multiple access (CDMA) transceiver.

Ex. 1001, 11:5–16, 11:39–42.

F. Ground of Unpatentability

The following ground of unpatentability and prior art references are at issue in this remand:

References	Basis	Claim Challenged
Jawanda, ² the GPRS Standard ³ and IEEE 802.11 Standard ⁴	§ 103(a)	8

Pet. 8; *see IPR Licensing, Inc.*, 685 F. App'x at 935.

II. ANALYSIS

A. Claim Construction

The Board interprets claims of an unexpired patent using the broadest reasonable interpretation in light of the specification of the patent in which they appear. *See* 37 C.F.R. § 42.100(b); *see also* *Cuozzo Speed Techs., LLC v. Lee*, 136 S.Ct. 2131, 2142 (2016) (affirming that USPTO has statutory authority to construe claims according to 37 C.F.R. § 42.100(b)). Under the broadest reasonable interpretation standard, claim terms are generally given their ordinary and customary meaning, as would be understood by one of ordinary skill in the art in the context of the entire disclosure. *In re Translogic Tech. Inc.*, 504 F.3d 1249, 1257 (Fed. Cir. 2007).

² U.S. Patent No. 6,243,581 B1, June 5, 2001 (filed Dec. 11, 1998) (Ex. 1003, “Jawanda”).

³ General Packet Radio Service Standards, (Ex. 1005, “GPRS Standards”).

⁴ Part 11: Wireless LAN Medium Access Control (MAC) and Physical Layer (PHY) Specifications, IEEE 802.11 Standard, Institute of Electrical and Electronics Engineers, Aug. 20, 1999, (Ex. 1019, “IEEE 802.11 Standard”).

We construed the term “plurality of assigned physical channels” in our Final Decision as “physical channels made available for use by the subscriber unit.” Final Dec. 13. The Federal Circuit confirmed our construction of “plurality of assigned physical channels” despite Patent Owner’s assertion that we relied on a new construction presented by Petitioner in its Reply. *IPR Licensing, Inc.*, 685 F. App’x at 937–938. The court characterized this as “harmless error” because Patent Owner did not show any detriment. Accordingly, we incorporate and maintain our construction of “plurality of assigned physical channels” in the present decision. Final Dec. 13; *IPR Licensing, Inc.*, 685 F. App’x at 938.

We determined that no other claim term needs express interpretation in our analysis of claim 8. *See Vivid Techs., Inc. v. Am. Sci. & Eng’g, Inc.*, 200 F.3d 795, 803 (Fed. Cir. 1999) (“[O]nly those terms need be construed that are in controversy, and only to the extent necessary to resolve the controversy.”).

B. Overview

Petitioner contends that claim 8 of the ’244 patent is unpatentable under 35 U.S.C. § 103(a) as obvious over Jawanda, the GPRS Standards, and IEEE 802.11 Standard. Pet. 19–28. In its Petition, Petitioner provides citations for where each claim limitation is disclosed by Jawanda, the GPRS Standards, and IEEE 802.11 Standard. Petitioner further relies on the declaration of Dr. Bims to support the analysis advocated in the Petition. Ex. 1002.

Having reviewed Petitioner’s arguments, Patent Owner’s arguments, and the supporting evidence, we determine that Petitioner has shown by a

preponderance of the evidence that claim 8 is unpatentable over Jawanda, the GPRS Standards, and IEEE 802.11 Standard. We begin our discussion with a brief summary of the cited references, and then we address the parties' contentions in turn.

1. Overview of Jawanda (Ex. 1003)

Jawanda discloses a method and system for seamless roaming between wireless data communication networks with a mobile terminal. Ex. 1003, 1:10–13. Specifically, the system includes a plurality of wireless interfaces that:

supports simultaneous wireless connections with first and second wireless communication networks, and a network access arbitrator that routes data communicated between the software executed by the data processing resources and the first and second wireless communication networks.

Id. at 1:64–2:1.

The system of wireless data communication between wireless data networks is illustrated in Figure 3, which is reproduced below.

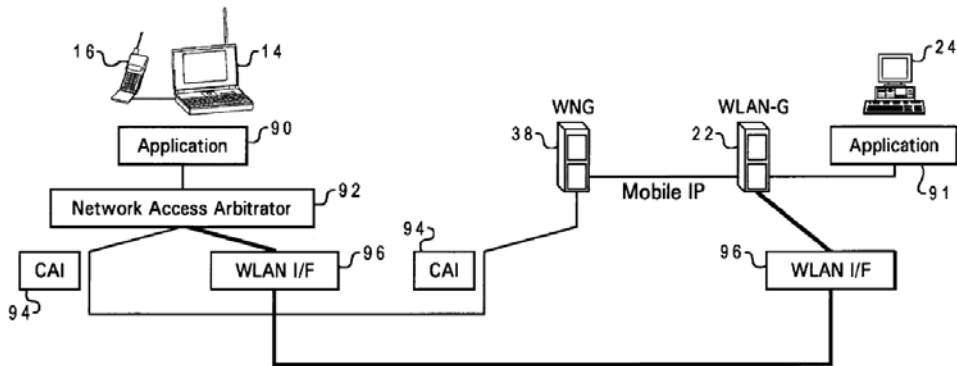

Fig. 3

Fig. 3 is a schematic diagram of a wireless data communication system for seamless roaming between wireless networks.

Jawanda discloses that the wireless signal can be transmitted according to any currently available or future wireless data protocol such as code division multiple access (CDMA), cellular digital packet data (CDPD), or general packet radio service (GPRS). *Id.* at 3:6–9. One of the functions of the network access arbitrator is to cause “the transfer of datagrams to be seamlessly handed off from the wireless connection with wireless wide area network (WWAN) 10 to the wireless connection with WLAN 12 while maintaining the session between applications 90 and 91.” *Id.* at 5:35–39, Fig. 4.

Figure 4, reproduced below, describes “a high level logical flowchart of a method of wireless data communication in which a data communication session is seamlessly handed off between wireless data communication networks.” Ex. 1003, 4:20–23.

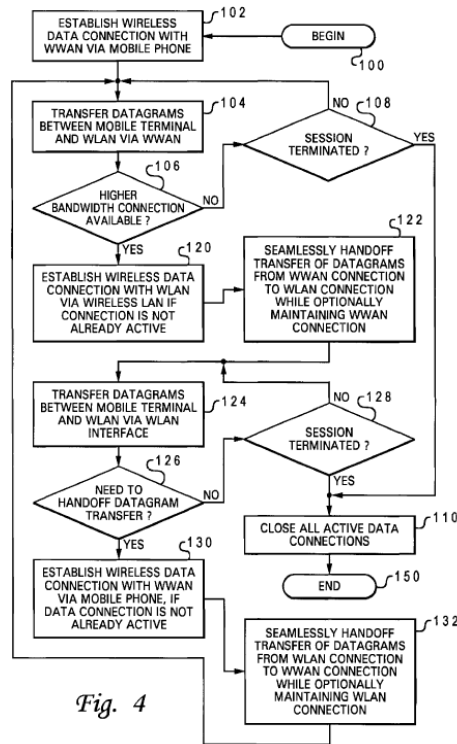

Fig. 4

Figure 4 illustrates communications handoff between wireless networks.

The methodology begins with the assumption that a wireless data connection between a mobile device and a WWAN 10 has been established outside the service area of the WLAN 12, and the mobile device travels into the service area of the WLAN 12, and then returns to the remote location. *Id.* at 4:24–30. In block 120, after detecting the availability of a higher bandwidth data connection, the mobile device establishes a second wireless data connection with a WLAN. *Id.* at 5:20–32. The Specification notes that “following block 120, the user has concurrent wireless data connections with both WWAN 10 and WLAN 12.” *Id.* at 5:32–34. Next, in block 122, the network arbitrator “causes the transfer of datagrams to be seamlessly handed off from the wireless connection with WWAN 10 to the wireless connection with WLAN 12 while maintaining the session between applications 90 and 91.” *Id.* at 5:34–39. Continuing to block 126, if for example, the mobile

device has moved out of the range of the WLAN 122, it is determined whether the transfer of datagrams should be handed off to the connection with WWAN 10, and the wireless connection is reestablished. *Id.* at 5:43–67.

2. Overview of GPRS Standards (Ex. 1005)

The reference to “GPRS Standards” pertains to ten sections from the Global System for Mobile Communication (GSM) standard, and defines features relating to a General Packet Radio Service (“GPRS”). Pet. 6. In particular, the GPRS Standards disclose the use of multiple physical data channels by a mobile station to transmit data. Pet. 21–22 (citing Ex. 1005.09, 6; Ex. 1002 ¶ 184). To transmit packet data, the physical channels may be grouped to form logical uplink channels (e.g., Packet Data Traffic Channel (“PDTCH”) and Packet Associated Control Channel (“PACCH”)). *Id.* at 22 (citing Ex. 1005.09, 6, 10; Ex. 1002 ¶ 184). A mobile station may allocate one or more of the assigned uplink PDTCHs as needed for transmission of data. *Id.* at 22 (citing Ex. 1005.09 § 2; Ex. 1002 ¶ 184). Further, a Packet Data Protocol Context (PDP Context) feature preserves information about the cellular communication session between the mobile device and base station. Ex. 1005.03, 79.

3. Overview of IEEE 802.11 Standard (Ex. 1019)

The IEEE 802.11 Standard is part of a family of networking standards dealing with wireless local and metropolitan area networks. Ex. 1019, 00005. In particular, the IEEE 802.11 Standard describes a wireless data protocol for Wireless LAN Medium Access Control (MAC) and a Physical Layer (PHY) Specification for wireless connectivity of fixed, portable, and moving stations within a local area. *Id.* at 00017.

4. Discussion

Petitioner bears the burden of proving unpatentability of the challenged claims, and the burden of persuasion never shifts to Patent Owner. *Dynamic Drinkware, LLC v. Nat'l Graphics, Inc.*, 800 F.3d 1375, 1378 (Fed. Cir. 2015). To prevail, Petitioner must establish the facts supporting its challenge by a preponderance of the evidence. 35 U.S.C. § 316(e); 37 C.F.R. § 42.1(d).

In its Petition, Petitioner argued that “Jawanda teaches and/or renders obvious all of the challenged claims, either alone or in combination with GPRS and IEEE 802.11 Standards.” Pet. 19. Specifically, that Jawanda discloses (1) a dual mode subscriber unit (mobile phone 16 connected to terminal unit 14); (2) a high speed wireless network (WLAN); and (3) “a lower-speed network such as a CDMA or GPRS cellular network. *Id.* at 20 (citing Ex. 1003, 2:42–47; Abstract; Ex. 1002 ¶¶ 177-179)). Petitioner relied on the GPRS Standards to provide the “implementation details” not particularly taught by Jawanda. Pet. 21. For example, in our Final Written Decision, we were persuaded by Petitioner that the “assigned physical channels” limitation of claim 1 was satisfied by the description in the GPRS Standards regarding “eight basic physical data channels per mobile station grouped to form logical uplink channels (e.g., Packet Data Traffic Channel (“PDTCH”) and a Packet Associated Control Channel (“PACCH”)) to transmit data, and that ‘a mobile station may allocate one or more of the assigned uplink PDTCHs as needed for transmission of data.’” Final Dec. 20 (citing Pet. 22 (internal citations omitted)). As to the “maintain a communication session” limitation of claim 1, we found that “the GPRS Standards ‘disclose a logical connection that can be maintained when

physical channels are absent or not in use.” *Id.* at 24 (internal citations omitted).

As noted above, the Federal Circuit affirmed our claim construction, and the Parties concurred that if our claim construction stood, then our finding that claim 1 is unpatentable as obvious based on Jawanda, the GPRS Standards, and IEEE 802.11 Standard is correct. *IPR Licensing, Inc.*, 685 F. App’x at 938–939. Specifically, our finding as to claim 1 that a person with ordinary skill in the art would have combined Jawanda, the GPRS Standards, and IEEE 802.11 Standard. Because this finding is uncontroverted, we focus our analysis on claim 8.⁵

Dependent claim 8 additionally recites that “the cellular wireless network is a code division multiple access (CDMA) network.” Ex. 1001, 11:39–41. Petitioner argued that the CDMA limitation of claim 8 is satisfied by the passage in Jawanda describing that, “[f]or data connections, such wireless signals can be transmitted according to *any currently available or future wireless data protocol such as code division multiple access (CDMA), CDPD, or GPRS.*” Pet. 45 (citing Ex. 1003, 3:6–9) (emphasis added).

Petitioner advanced several reasons, supported by the testimony of Dr. Bims, explaining why one of skill in the art would have been motivated to combine the teachings of Jawanda with the GPRS and IEEE 8.02.11 standards. Pet. 26–28. For example, Petitioner argued that “Jawanda provides an express motivation to combine its teachings with the GPRS and IEEE 802.11 Standards,” namely because Jawanda teaches both a WWAN and WLAN for use with a mobile terminal, and that the mobile terminal and

⁵ We note that any allegation by Patent Owner that Petitioner’s arguments in its reply were outside the scope is moot because we did not rely on such arguments in our reconsideration of claim 8.

mobile phone “can communicate with the WWAN ‘according to any currently available or future wireless data protocol such as code division multiple access (CDMA), CDPD, *or GPRS.*” *Id.* at. 26 (citing Ex. 1003, 3:1–9, 4:31–34, Fig. 1); Ex. 1002 ¶¶ 181–182. Petitioner also argued that “it would have been an obvious design choice to a person of ordinary skill in the art that the mobile phone in Jawanda be selected to comply with the then-existing, well-known GPRS Standard. *Id.* at 27 (citing Ex. 1002 ¶ 166). Further, Petitioner argued that “a person of ordinary skill would have found it obvious to reference the GPRS Standards for details about how to implement the cellular features taught in Jawanda.” *Id.* at 27 (citing Ex. 1002 ¶ 122). According to Petitioner, it would have been obvious to implement the WLAN using the IEEE 802.11 Standard because (1) “it was the first publically available and internationally accepted wireless data protocol for WLANs” amongst few available options (*id.* (citing Ex. 1002 ¶¶ 138-150, 167)); and (2) “one of ordinary skill naturally would have looked to the IEEE 802.11 Standard for details on how to realize the WLAN implementation described in Jawanda (*id.* at 27–28 (citing Ex. 1002 ¶¶ 138-150, 167)).

In response to these rationales, Patent Owner argued that because GPRS uses time division multiple access (TDMA) and not CDMA, “Jawanda with GPRS does not include a cellular network that is a CDMA network.” PO Resp. 39. The Federal Circuit found that “the suggestion in Jawanda to combine Jawanda with GPRS or CDMA *is not a suggestion to combine Jawanda and specific features of GPRS with CDMA.*” *IPR Licensing, Inc.*, 685 F. App’x at 939. (emphasis added). At the same time, the Court also recognized that “the record might contain substantial evidence

to support a motivation to combine the PDP Context feature of the GPRS Standards with the CDMA network referenced in Jawanda.” *Id.* at 940.

Central to Patent Owner’s argument that “Jawanda with GPRS does not include a cellular network that is a CDMA network” is the fact that TDMA and CDMA are different cellular network protocols. PO Resp. 39. Patent Owner supports its position with the testimony of Dr. Stark, that “[a] person of ordinary skill in the art would understand that these are fundamentally different approaches to multiple-access, and therefore, it would be improper to rely on a TDMA system, such as GPRS, for purposes of the independent claims while relying on a CDMA system for purposes of the dependent claims.” Ex. 2005 ¶ 127.

Patent Owner’s arguments directed specifically to the GPRS Standards, presume that one of ordinary skill would not look outside the confines of the GPRS Standards for any modification. This approach, however, is contrary to *KSR*, which states “[a] person of ordinary skill is also a person of ordinary creativity, not an automaton.” *KSR Int’l Co. v. Teleflex Inc.*, 550 U.S. 398, 406 (2007). *KSR* explains explicitly that the ordinary artisan recognizes “that familiar items may have obvious uses ***beyond their primary purposes***, and in many cases a person of ordinary skill will be able to fit the teachings of multiple patents together like pieces of a puzzle.” *KSR Int’l Co.*, 550 U.S. at 420 (emphasis added).

We find more persuasive the evidence in the record demonstrating that the ’244 patent itself recognizes that CDMA was a known digital wireless communication protocol in the relevant timeframe. For example, the background of the invention describes the use of advanced digital wireless communication protocols, such as CDMA. Ex. 1001, 1:64–66. In

explaining how the multichannel digital transceiver provides access to physical communication links, the '244 patent states that “[t]he physical links *are preferably known* wireless communication air interfaces using digital modulation techniques such as Code Division Multiple Access (CDMA) standard specified by IS-95.” *Id.* at 5:31–34 (emphasis added).

In addition, we credit the testimony of Petitioner’s expert, Dr. Bims, that

GSM and CDMA were both well-known ‘2G’ cellular network technologies, providing for primarily voice communications over wireless channels. GSM was developed by the European Telecommunications Standards Institute (ETSI) in the late 1990’s, and CDMA was first implemented by Qualcomm in the mid 1990’s as TIA Interim Standard 95 (IS-95). Packet data overlays for GSM (GPRS) and CDMA (IS-657) were developed shortly thereafter to improve data communications using such wireless networks. GSM and CDMA matured into the UMTS and CDMA2000 Standards, and ultimately into the 4G LTE popular today.

Ex. 1002 ¶ 119. We also credit the testimony of Dr. Bims that one of ordinary skill in the art at the time of the claimed invention would have been aware of the problem of mobile devices frequently switching between networks and of solutions “to transparently maintain a communication session when handing off the session to a different type of physical connection.” *Id.* at ¶ 151.

Additionally, our review of the GPRS Standard reveals that it is not as restrictive as Patent Owner’s expert, Dr. Stark, suggests (*see e.g.*, Ex. 2005 ¶ 127 “GPRS uses time-division multiple access (“TDMA”), whereby a base station selects channels by assigning time slots to the subscriber unit, and different subscriber units transmit data at different times. This is in contrast

to a CDMA system, where subscriber units use spreading codes to transmit data, and therefore can transmit data at the same time. A person of ordinary skill in the art would understand that these are fundamentally different approaches to multiple-access”). For example, the GPRS Standard recognizes that “additional functionalities not documented in this EN may be implemented [t]his additional functionality may be on a network-wide basis, or particular to one or a group of users.” Ex. 1005.01, 6. Moreover, the GPRS Standard states that “[t]he GPRS shall not prevent the user’s operation of other GSM services.” *Id.* at 13.

Further, we are persuaded that the Petition and supporting evidence shows that the PDP context feature was not limited in its use to only GPRS. Indeed, Petitioner demonstrates convincingly the inclusion of the PDP context feature in a CDMA-based standard in arguing that “[t]he same PDP Context feature disclosed in the GPRS Standards is also included in the subsequent 3GPP Wideband Code Division Multiple Access (“WCDMA”) standard. Pet. 25 (citing Ex. 1023; Ex. 1002 ¶ 134–35). For instance, Dr. Bims testifies, and we agree, that a CDMA-based system (i.e., UMTS) included a PDP context for session management and routing information. Ex. 1002 ¶ 134–135; *see also* Pet. 35. Dr. Bims further supports his opinions with evidence of a need to allow a mobile device to roam without interrupting existing communication sessions and for maintaining connections when the mobile device changes location. Ex. 1002 ¶¶ 158–164. Having accessible the known cellular standards and their data transport protocols and given the need addressed in the record, a person of ordinary skill in the art would have substituted one cellular network protocol for another to yield a predictable result in this field of technology. *Id.* ¶ 165

(stating substitution rationale); *see also id.* ¶¶ 120–121 (stating that GPRS and UTMS, among others, were open standards and engineers developing cellular devices would access the standards documents); Ex. 2006, 25:4–27:2.

After considering anew the arguments and evidence presented during trial, we remain persuaded that Petitioner presented sufficient arguments and credible evidence to support a finding that one of ordinary skill in the art at the time of the invention would have been motivated to utilize the CDMA network as the cellular wireless network, as required by claim 8, in the combination of Jawanda, the GPRS Standards, and IEEE 802.11 Standard. Namely, because (1) Jawanda expressly labels CDMA or GPRS as available wireless data protocols (Pet. 26; *see also* Ex. 2006: 19:20–20:18 (opining that Jawanda’s disclosure of CDMA-based protocol as an alternative includes UMTS, because is a CDMA-based protocol)); (2) it would have been obvious “to a person of ordinary skill in the art that the mobile phone in Jawanda be selected to comply with the then-existing, well-known GPRS Standard” (Pet. 27 (citing Ex. 1002 ¶ 166); *see also* Ex. 2006); and (3) “a person of ordinary skill would have found it obvious to reference the GPRS Standards for details about how to implement the cellular features taught in Jawanda” (Pet. 27 (citing Ex. 1002 ¶ 122)).

Further, we are persuaded that the record presents sufficient evidence that the PDP context feature was desirable for addressing the needs of allowing uninterrupted communication while roaming or connecting to different networks. And because UMTS included a “PDP context” feature, the use of that feature in a CDMA-based system was not only known, but

recognized as beneficial for the same reasons it is beneficial in GPRS:
session management and routing information.

We previously determined, and the Federal Circuit sustained, that Petitioner established by a preponderance of the evidence that independent claim 1 is unpatentable over Jawanda, the GPRS Standards, and IEEE 802.11 Standard. Having considered claim 8 as a whole, which includes the limitations of claim 1 from which it depends, we determine that Petitioner has established by a preponderance of the evidence that claim 8 of the '244 patent is unpatentable over Jawanda, the GPRS Standards, and IEEE 802.11 Standard.

III. CONCLUSION

For the foregoing reasons, we determine that Petitioner has established by a preponderance of the evidence that claim 8 of the '244 patent is unpatentable over Jawanda, the GPRS Standards, and IEEE 802.11 Standard.

IV. ORDER

Accordingly, it is hereby:

ORDERED that claim 8 of the '244 patent has been shown to be unpatentable by a preponderance of the evidence; and

FURTHER ORDERED that, because this Decision on Remand is a Final Written Decision, the parties to the proceeding seeking judicial review of the Decision must comply with the notice and service requirements of 37 C.F.R. § 90.2.

IPR2014-00525
Patent 8,380,244 B2

PETITIONER:

Charles M. McMahon
Brian A. Jones
BRINKS GILSON & LIONE
bjones@brinksgilson.com
cmcMahon@brinksgilson.com

PATENT OWNER:

Julie M. Holloway
Jonathan M. Strang
LATHAM & WATKINS LLP
julie.holloway@lw.com
jonathan.strang@lw.com