

**IN THE UNITED STATES DISTRICT COURT
FOR THE EASTERN DISTRICT OF TEXAS
MARSHALL DIVISION**

ELBIT SYSTEMS LAND AND C4I LTD.,	§	
ELBIT SYSTEMS OF AMERICA, LLC,	§	
	§	Case No. 2:15-CV-00037-RWS-RSP
<i>Plaintiffs,</i>	§	
	§	
v.	§	
	§	
HUGHES NETWORK SYSTEMS, LLC,	§	
BLUETIDE COMMUNICATIONS, INC.,	§	
COUNTRY HOME INVESTMENTS, INC.,	§	
	§	
<i>Defendants.</i>	§	

**MEMORANDUM OPINION AND ORDER AND
REPORT AND RECOMMENDATION**

Before the Court are the following motions:

- (1) Plaintiffs’ Motion to Strike Expert Opinions Regarding Stricken Prior Art References And Undisclosed Invalidity Theories (**Dkt. 275**) (“Elbit’s Motion to Strike Invalidity Opinions”).
- (2) Defendant Hughes Network Systems, LLC’s Motion to Strike Elbit’s ’874 Patent Infringement Contentions (**Dkt. 276**) (“Hughes’ Motion to Strike Infringement Contentions”).
- (3) Defendant Hughes’s Motion to Exclude Elbit’s New Priority Date Contentions for the ’073 Patent (**Dkt. 277**) (“Hughes’ Priority Date Motion”).
- (4) Defendants’ Motion for Summary Judgment of Noninfringement of the Switching Means of United States Patent No. 6,240,073 (**Dkt. 291**) (“Defendants’ ‘Switching Means’ Motion”).
- (5) Defendants Motion for Summary Judgment of Non-Infringement of Claim 28 of the ’073 Patent for Lack of a “Means For Generating A Request” (**Dkt. 292**) (“Defendants’ ‘Means for Generating Request’ Motion”).
- (6) Defendants’ Motion for Partial Summary Judgment of Non-Infringement for Hughes’ GMR-1 Products (**Dkt. 293**) (“Defendants’ GMR-1 Products Motion”).
- (7) Defendants’ Motion for Partial Summary Judgment of No Damages With Respect to the ’874 Patent (**Dkt. 294**) (“Defendants’ Damages Motion”).

- (8) Defendant Hughes Network Systems, LLC's Motion for Summary Judgment of No Copying of U.S. Patent No. 6, 240,073 (**Dkt. 295**) ("Hughes' Copying Motion")
- (9) Defendant Hughes Network Systems, LLC's Motion for Summary Judgment of No Willfulness (**Dkt. 296**) ("Hughes' Willfulness Motion").
- (10) Defendant Hughes Network Systems, LLC's Motion for Summary Judgment of No Pre-Suit Damages Based on Plaintiffs' Failure to Comply with 35 U.S.C. § 287 (**Dkt. 297**) ("Hughes' Marking Motion").
- (11) Defendant Hughes Network Systems, LLC's Motion for Partial Summary Judgment of Non-Infringement of Claims 2-5, 7-9, 11, and 12 of U.S. Patent No. 7,245,874 (**Dkt. 298**) ("Motion for Summary Judgment of Noninfringement of the '874 Patent").
- (12) Plaintiffs' Motion to Exclude the Testimony of Dr. Stephen B. Wicker (**Dkt. 312**) ("Elbit's Infringement Expert Motion").
- (13) Defendant Hughes Network Systems, LLC's Motion to Exclude Expert Testimony of Stephen G. Kunin (**Dkt. 313**) ("Hughes' Motion to Exclude Patent Office Expert Testimony")
- (14) Defendants' *Daubert* Motion to Exclude the Opinions Offered by Christopher Martinez (**Dkt. 314**) ("Defendants' Motion to Exclude Damages Expert Testimony").
- (15) Plaintiffs' Motion to Strike Defendants' Experts Opinions Regarding Previously-Undisclosed Non-Infringing Alternatives (**Dkt. 315**) ("Plaintiffs' Motion to Strike Non-Infringing Alternatives")
- (16) Hughes' Motion to Strike Portions of Elbit's Expert Reports that Rely on Previously-Unidentified Infringement Theories (**Dkt. 316**) ("Hughes' Motion to Strike Infringement Opinions").
- (17) Plaintiffs' Motion to Exclude Certain Opinions of Defendants' Damages Expert, Mr. W. Christopher Bakewell (**Dkt. 319**) ("Elbit's Motion to Exclude Damages Expert Testimony").
- (18) Defendants Hughes Network Systems, LLC And BlueTide Communications, Inc.'s Motion to Transfer Under 28 U.S.C. § 1406 (**Dkt. 372**) ("Defendants' Motion to Transfer").
- (19) Defendants Hughes Network Systems, LLC And BlueTide Communications, Inc.'s Motion to Stay Proceedings Pending Resolution of Proper Venue (**Dkt. 373**) ("Defendants' Motion to Stay").

The Court resolves the nondispositive motions and provides recommendations for the pending motions for summary judgment as follows. *See* Fed. R. Civ. P. 72.

TABLE OF CONTENTS

BACKGROUND 4

DISCUSSION 4

 A. Defendants’ Motions for Summary Judgment 4

 1. Motions for Summary Judgment of Noninfringement of the ’073 Patent..... 5

 2. Defendants’ Damages Motion (Dkt. 294) 8

 3. Hughes’ Copying Motion (Dkt. 295) 9

 4. Hughes’ Willfulness Motion (Dkt. 296)..... 10

 5. Hughes’ Marking Motion (Dkt. 297) 12

 6. Motion for Summary Judgment of Noninfringement of the ’874 Patent (Dkt. 298).. 14

 B. Motions to Strike or Exclude Contentions or Opinions 15

 1. Elbit’s Motion to Strike Invalidity Opinions (Dkt. 275) 15

 2. Hughes’ Motion to Strike Infringement Contentions (Dkt. 276) 17

 3. Hughes’ Priority Date Motion (Dkt. 277) 18

 4. Plaintiffs’ Motion to Strike Non-Infringing Alternatives (Dkt. 315) 20

 5. Hughes’ Motion to Strike Infringement Opinions (Dkt. 316) 23

 C. *Daubert* Motions 27

 1. Elbit’s Infringement Expert Motion (Dkt. 312)..... 27

 2. Hughes’ Motion to Exclude Patent Office Expert Testimony (Dkt. 313) 29

 3. Defendants’ Motion to Exclude Damages Expert Testimony (Dkt. 314) 31

 4. Elbit's Motion to Exclude Damages Expert Testimony (Dkt. 319)..... 34

 D. Defendants’ Motions to Transfer and Stay (Dkts. 372 and 373) 36

 1. Relevant Procedural Background 37

 2. Waiver of Venue Defense..... 38

 3. Defendants’ Pending Motion to Transfer under § 1404 (Dkt. 130) 41

CONCLUSION..... 44

BACKGROUND

This is a patent infringement case brought by Elbit Systems Land and C4I Ltd and Elbit Systems of America LLC (collectively, “Elbit”). Elbit accuses Hughes Networks Systems, LLC (“Hughes”), BlueTide Communications, Inc. (“BlueTide”), and Country Home Investments, Inc. (“Country Home”) of infringing U.S. Patent Nos. 6,240,073 (“the ’073 patent”) and 7,245,874 (“the ’874 patent”), both of which relate generally to satellite communication systems.

DISCUSSION

A. Defendants’ Motions for Summary Judgment

Defendants move for summary judgment on various claims and issues underlying Elbit’s infringement and damages contentions. Summary judgment must be granted when there is no genuine issue as to any material fact and the movant is entitled to judgment as a matter of law. Fed. R. Civ. P. 56(c). “A genuine issue of material fact exists ‘if the evidence is such that a reasonable jury could return a verdict for the non-moving party.’” *Crawford v. Formosa Plastics Corp., La.*, 234 F.3d 899, 902 (5th Cir. 2000) (quoting *Anderson v. Liberty Lobby, Inc.*, 477 U.S. 242, 248 (1986)). The court must consider evidence in the record in the light most favorable to the non-moving party and draw all reasonable inferences in favor of that party. *Thorson v. Epps*, 701 F.3d 444, 445 (5th Cir. 2012). The moving party must identify the portions of the record that demonstrate the absence of a genuine issue of material fact. *Celotex Corp. v. Catrett*, 477 U.S. 317, 323 (1986). Once a party has made that showing, the non-moving party bears the burden of establishing otherwise. *Geiserman v. MacDonald*, 893 F.2d 787, 793 (5th Cir. 1990) (citing *Celotex*, 477 U.S. at 323). The non-moving party cannot “rest upon mere allegations or denials” in the pleadings, but “must set forth specific facts showing there is a genuine issue for trial.” *Liberty Lobby*, 477 U.S. at 248. Thus, summary judgment “is appropriate if the non-movant ‘fails

to make a showing sufficient to establish the existence of an element essential to that party's case.”
Bluebonnet Hotel Ventures, LLC v. Wells Fargo Bank, N.A., 754 F.3d 272, 276 (5th Cir. 2014)
(quoting *Celotex*, 477 U.S. at 322).

1. Motions for Summary Judgment of Noninfringement of the '073 Patent

a) Defendants' "Switching Means" Motion (Dkt. 291)

The asserted '073 patent claims recite a “switching means . . . for switching transmission between said first communication means and said second communication means in accordance with predefined criteria.” *See, e.g.*, '073 patent at 22:66-23:2. The Court construed the switching means limitation as a means-plus-function term governed by 35 U.S.C. § 112, ¶ 6. Dkt. 208, at 30. The Court defined the corresponding structure as “modem 160 or PC 150 including driver layer 158 performing the algorithms disclosed in the '073 Patent at 10:30-11:40 or Figure 8, and equivalents thereof.” *Id.* Hughes contends that “[i]n the '073 Patent, the modem 160 and the PC 150 are part of the terminal and not part of the hub.” *See* Dkt. 291 at 4 (citing '073 Patent, Fig. 7). According to Hughes, Elbit has failed to identify “switching means” structure at or within the terminal, but rather only identifies structure at the hub, and thus summary judgment of noninfringement should be granted *Id.* at 9.

Elbit's expert, Bruce Elbert, opines to the contrary. Mr. Elbert explains that the accused terminals begin transmitting in random access mode, and when a terminal receives user data, the terminal compares the size of the data to the amount of space in the Aloha transmission. *See* Dkt. 318-2 ¶¶ 301-19. Based on that comparison, Mr. Elbert opines that the terminal decides whether to switch to an allocated channel, depending on whether the user data fit within the Aloha transmission. *Id.* The terminal then allegedly waits for the hub to acknowledge that a specific channel has been assigned. *Id.* This algorithm, according to Mr. Elbert, is consistent with the one

disclosed in the '073 patent at 10:30-11:40. *See* Dkt. 318 at 8. Mr. Elbert's testimony attributes the decision to switch transmission to the terminal, and thus this testimony "at least raises a genuine issue of material fact" concerning infringement. *See Vasudevan Software, Inc. v. MicroStrategy, Inc.*, 782 F.3d 671, 683 (Fed. Cir. 2015).

Hughes argues Elbit is estopped from making such arguments because of statements Elbit made during *inter partes* review. This argument is not persuasive. Mr. Elbert's testimony appears consistent with representations Elbit made to the Patent Office concerning where the decision to switch occurs. The Court therefore **RECOMMENDS** Defendants' "Switching Means" Motion be denied.

b) Defendants' "Means for Generating Request" Motion (Dkt. 292)

Claim 28 of the '073 patent recites a "means for generating a request." This means-plus-function limitation corresponds to algorithms described in the specification. One algorithm requires that the generated request include a requested date. *See* Dkt. 292 at 1. The other alternative algorithm requires the request to be based on an evaluation of a port number. *See id.* Hughes argues the accused terminals do not generate a request including a requested data rate or port number. *See id.* Thus, according to Hughes, summary judgment of noninfringement of claim 28 should be granted.

Elbit's expert testimony, however, raises a material factual dispute. Mr. Elbert explains how the accused products satisfy the "means for generating a request" limitation, and Mr. Elbert includes an analysis of how the accused structures are equivalent to the structure corresponding to the claim limitation. *See* Dkt. 318-2 ¶¶ 451-54, 458-61. Infringement under the doctrine of equivalents is a "highly factual inquiry." *Jeneric/Pentron, Inc. v. Dillon Co., Inc.*, 205 F.3d 1377, 1384 (Fed. Cir. 2000). Mr. Elbert's testimony suggesting that the "means for generating" limitation

is met under the function-way-results or substantial similarity tests precludes the grant of summary judgment. *See Vasudevan Software*, 782 F.3d at 683 (Fed. Cir. 2015). The Court therefore **RECOMMENDS** Defendants’ “Means for Generating Request” Motion be denied.

c) Defendants’ GMR-1 Products Motion (Dkt. 293)

Defendants explain that Elbit originally accused Hughes’ products that comply with the GMR-1 standard of infringing the ’073 patent. Dkt. 293 at 1. Elbit did not, however, include opinions concerning these infringement theories in its expert report, and Elbit acknowledges that it will not pursue such theories at trial. *Id.* As a result, Defendants contend they are entitled to summary judgment of noninfringement as to the GMR-1 products. *Id.*

The Court disagrees. Elbit voluntarily dropped the GMR-1 products before expert discovery—an action that is similar to amending a complaint or voluntarily dismissing claims without prejudice. *See Sandisk Corp v. Kingston Tech. Co.*, 695 F. 3d 1348, 1353 (treating a plaintiff’s withdrawal of asserted claims “as being akin to either a [Fed. R. Civ. P.] 15 amendment to the complaint, or a Rule 41(a) voluntary dismissal of claims without prejudice”) (citations omitted). Defendants highlight that Elbit refuses to enter into a stipulation dismissing the GMR-1 products from the case, but Defendants do not cite authority suggesting Elbit has an obligation to do so. *See Alcon Research Ltd. v. Barr Labs., Inc.*, 745 F.3d 1180, 1193 (Fed. Cir. 2014) (“[W]e have not previously held that a formal motion or stipulation was required to remove claims from a case and we decline to do so here. On the contrary, we recently decided that a patentee’s announcement that it was no longer pursuing certain claims, coupled with its ceasing to litigate them, was sufficient to remove those claims from the case even without such formalities.”). The Court therefore **RECOMMENDS** Defendants’ GMR-1 Products Motion be denied.

2. Defendants' Damages Motion (Dkt. 294)

Hughes contends that it is entitled to summary judgment of no damages arising from the alleged infringement of the '874 patent because Elbit's damages expert, Mr. Christopher Martinez, "offers no opinion on damages for the '874 Patent." Dkt. 294 at 1. According to Hughes, there is no other evidence in the record on which Elbit may rely, and thus summary judgment of no damages is appropriate. *Id.*

Hughes' own damages expert's report, however, is part of the summary judgment record, and the report includes Mr. Christopher Bakewell's opinion that the appropriate royalty for the "alleged infringement of the patents-in-suit is a lump-sum of no greater than \$3.5 million, which can be allocated as \$2.5 million for the '073 patent and \$1 million for the '874 patent." Dkt. 319-1 ¶ 559. Hughes argues this report is not competent summary judgment evidence because it is hearsay, but Hughes' argument appears to conflict with Fifth Circuit law finding an opponent's expert's statement admissible under Rule 801(d)(2)(c). *See, e.g., Collins v. Wayne Corp.*, 621 F.2d 777, 782 (5th Cir. 1980) (statement by expert nonhearsay because expert "was performing the function that [the party opponent] had employed him to perform.").

The Court need not reach the hearsay issue, however, because there is other summary judgment evidence suggesting that a zero royalty is not the only reasonable royalty for the '874 patent. Mr. Bakewell opines that products accused of infringing the '874 patent "are a subset of those that are accused of infringing the '073 patent." *See* Dkt. 319-1, ¶ 325. Mr. Martinez opines that the parties would have had a single hypothetical negotiation for both asserted patents, and Mr. Martinez's testimony can be regarded as proffering a non-zero royalty opinion for the '874 patent; otherwise, there would have been no need to opine that a "joint" hypothetical negotiation for both asserted patents would have occurred. *See* Dkt. 321 at 4.

“At summary judgment, as is the case here, a judge may only award a zero royalty for infringement if there is no genuine issue of material fact that zero is the only reasonable royalty.” *Apple Inc. v. Motorola, Inc.*, 757 F.3d 1286, 1328 (Fed. Cir. 2014). The contrary authority cited by Hughes—*Unicom Monitoring, LLC v. Cencom, Inc.*, No. CIV.A. 06-1166 MLC, 2013 WL 1704300, at *6 (D.N.J. Apr. 19, 2013)—was decided before *Apple*. Indeed, *Unicom* relies on the summary judgment decision vacated by the panel in *Apple*, i.e., *Apple, Inc. v. Motorola Inc.*, 869 F.Supp.2d 901 (N.D.Ill.2012) (Posner, J., sitting by designation). In sum, because the summary judgment evidence does not suggest that zero is the only reasonable royalty for the ’874 patent, the Court **RECOMMENDS** Defendants’ Damages Motion be denied.

3. Hughes’ Copying Motion (Dkt. 295)

Hughes seeks summary judgment that Hughes did not copy the invention claimed in the ’073 patent, which, according to Hughes, should preclude Elbit from relying on copying as objective evidence of nonobviousness. *See* Dkt. 295. Hughes contends Elbit has not shown copying of “a specific product,” *id.* at 5, because Shiron (Elbit’s predecessor) “did not have a product practicing the ’073 Patent until 2003, two years after Hughes began selling the allegedly infringing [product],” Dkt. 324 at 1.

To establish copying, a patent owner may present evidence that an accused infringer replicated the patentee’s product rather than independently develop its own product. *See Wyers v. Master Lock Co.*, 616 F.3d 1231, 1246 (Fed. Cir. 2010). The patent owner need not establish that the accused infringer copied a specific physical product embodied by an issued patent—copying a written formula or prototype is sufficient, for example. *Advanced Display Systems, Inc. v. Kent State University*, 212 F.3d 1272, 1276 (Fed. Cir. 2000). Indeed, an accused infringer’s efforts to

replicate a claimed invention from the disclosure in a patent or patent application may be sufficient. *DePuy Spine, Inc. v. Medtronic Sofamor Danek, Inc.*, 567 F.3d 1314, 1328-29 (Fed. Cir. 2009).

Consistent with this standard, Elbit presents evidence of a presentation (albeit before the '073 patent issued) in which Shiron showed Hughes a confidential proposal for a “high-speed return link via satellite” product, similar to the written formula in *Advanced Display Systems*. See 212 F.3d at 127; Dkt. 322 at 19. Elbit also presents evidence that Hughes was generally familiar with Shiron and Elbit’s products and, on one occasion in 2014, compared Hughes’ products with Elbit’s products as part of an effort to secure a contract. See Dkt. 295-8 at 14.

Hughes and Elbit are competitors, which gives credence to this evidence. See *WBIP, LLC v. Kohler Co.*, 829 F.3d 1317, 1336 (Fed. Cir. 2016) (“The fact that a competitor copied technology suggests it would not have been obvious.”). Hughes contends that Elbit fails to show a nexus between the alleged copying and the patented invention, but Elbit provides reasonably-supported expert testimony on the matter, thus reducing the dispute to a factual one for the jury to resolve. See Dkt. 322; *WBIP*, 829 F.3d at 1336 (“Copying is a question of fact and, as with any question of fact, the fact-finder (here, the jury) was entitled to credit WBIP’s evidence over Kohler’s.”). The Court therefore **RECOMMENDS** Hughes’ Copying Motion be denied.

4. Hughes’ Willfulness Motion (Dkt. 296)

Hughes seeks summary judgment of no willfulness because Elbit “cannot point to evidence that is sufficient, as a matter of law, to show that Hughes willfully infringed” the asserted patents. Dkt. 296 at 1. In response to Hughes’ motion, Elbit highlights evidence supporting its contention that Hughes knew the asserted patents were valid and infringed. For example, Elbit points to evidence that its predecessor, Shiron, presented an embodiment of the '073 patent to Hughes’ senior executives in 1997, that Hughes had knowledge of the asserted patents through

correspondence between Hughes' in-house counsel and Shiron's agent, and that Hughes' in-house counsel and senior engineers possessed claim charts detailing how Hughes' products are encompassed by the asserted patent claims. *See, e.g.*, Dkt. 322 at 2-3, 6-9.

There is sufficient evidence to create a fact dispute as to Hughes' state of mind before beginning the allegedly infringing conduct. Determining willfulness is a fact-based endeavor. Hughes argues that it had good faith reasons to believe that the patent did not encompass the accused system and that the patent was invalid. *See* Dkt. 296. Indeed, Hughes' summary judgment motions of noninfringement provide support for the contention that it was at least not clear that the asserted patents were both valid and infringed. The Supreme Court has explained, however, that the issue of willfulness turns not on the objective reasonableness of a defendant's conduct, but on the defendant's subjective beliefs. *Halo Elecs., Inc. v. Pulse Elecs., Inc.*, 136 S. Ct. 1923, 1933 (2016) ("The subjective willfulness of a patent infringer, intentional or knowing, may warrant enhanced damages, without regard to whether his infringement was objectively reckless.").

A jury might conclude from Hughes' objective evidence that Hughes did not subjectively believe it was infringing a valid patent. *See WesternGeco L.L.C. v. Ion Geophysical Corp.*, 837 F.3d 1358, 1363 (Fed. Cir. 2016) (even after *Halo*, the objective reasonableness of the accused infringer's positions can still be relevant to § 284). But Hughes has not offered other summary judgment evidence regarding its executives' subjective beliefs. Given the state of the evidence, the Court cannot conclude that it would be unreasonable for a jury to find Hughes knew the asserted patents were valid and infringed. The Court therefore **RECOMMENDS** Hughes' Willfulness Motion be denied.

The Court is nevertheless mindful of the Supreme Court's clarification that case law has channeled courts' discretion in granting enhanced damages under § 284—limiting the award of

such damages “to egregious cases of misconduct beyond typical infringement.” *Halo*, 136 S. Ct. at 1935. The Court will be in a better position after receiving the evidence at trial to determine whether Elbit has demonstrated the level of willfulness necessary to warrant enhanced damages if Elbit prevails.

5. Hughes’ Marking Motion (Dkt. 297)

Hughes moves for summary judgment of no pre-suit damages under the ’073 patent because Elbit allegedly failed to comply with the notice requirements of the marking statute, 35 U.S.C. § 287(a). According to Hughes, because Elbit failed to comply with the statute, damages may only accrue from January 21, 2015, the date Elbit filed suit.

“The patent marking statute limits recoverable damages where a patentee fails to mark her patented products.” *Power Integrations, Inc. v. Fairchild Semiconductor Int’l, Inc.*, 711 F.3d 1348, 1378 (Fed. Cir. 2013) *cert. denied*, 134 S. Ct. 900 (2014). “Where a patentee does not appropriately mark her products, she may not recover damages for infringement occurring before notice to the infringer.” *Id.* The statute provides two ways to provide notice: a patentee can (1) provide actual notice; or (2) provide constructive notice “by affixing . . . the word ‘patent’ or the abbreviation ‘pat.’, together with the number of the patent” on patented articles sold by the patentee or its licensees. 35 U.S.C. § 287. “[A] party that does not mark a patented article is not entitled to damages for infringement prior to actual notice.” *Crown Packaging Tech., Inc. v. Rexam Beverage Can Co.*, 559 F.3d 1308, 1316 (Fed. Cir. 2009).

“For purposes of section 287(a), [actual] notice must be of ‘the infringement,’ not merely notice of the patent’s existence or ownership. Actual notice requires the affirmative communication of a specific charge of infringement by a specific accused product or device.” *Amsted Indus. Inc. v. Buckeye Steel Castings Co.*, 24 F.3d 178, 187 (Fed. Cir. 1994) (quoting

§ 287(a)). “It is irrelevant . . . whether the defendant knew of the patent or knew of his own infringement. The correct approach to determining notice under section 287 must focus on the action of the patentee, not the knowledge or understanding of the infringer.” *Id.*

Elbit identifies sufficient summary judgment evidence to create a fact dispute concerning whether Hughes had actual notice of the '073 patent and the charge of infringement. A juror could conclude that iLeverage's former CEO, Uzi Aloush, provided actual notice sufficient to satisfy the marking statute. Mr. Aloush testified that iLeverage “had the right to act as the exclusive worldwide agent to commercialize” the '073 patent. *See* Dkt. 322-11 at 35:24-36:8. Mr. Aloush explained that during talks with Hughes about a license to the '073 patent, he told Hughes that it infringed the patent. *See id.* at 139:2-140:9. Hughes corroborates that such talks took place through an interrogatory response stating that “[i]n 2008, Hughes was approached by iLeverage regarding Shiron's patents, including U.S. Patent Nos. 6,240,073 or 7,245,874. At that time, Hughes communicated with iLeverage regarding U.S. Patent Nos. 6,240,073 or 7,245,874.” Dkt. 322-25 at 24.

Hughes' argument in response to this evidence is that § 287 is an affirmative step that must be taken by the patentee, and that the iLeverage talks do not qualify because iLeverage “did not have authority from Shiron to accuse Hughes of infringement.” Dkt. 324 at 8. To support this argument, Hughes cites the following testimony from Mr. Aloush's deposition:

Q: You did not have any authority from Shiron to make any accusation of patent infringement; is that correct?

A: We were brokers. We were not lawyers. It was not a cease and desist letter. It was just an offer for sale.

Dkt. 297-8 at 156:14-157:17. This testimony, however, does not suggest that iLeverage could not have provided actual notice of the patent and the charge of infringement, as Shiron's agent, in a manner sufficient to comply with the marking statute.

If Hughes is arguing that iLeverage would not have been considered an effective patentee when it offered to sell the system allegedly covered by the '073 patent, Hughes' argument is not clear. "[I]f the patentee transfers all substantial rights under the patent, it amounts to an assignment and the assignee may be deemed the effective patentee under 35 U.S.C. § 281 for purposes of holding constitutional standing to sue another for patent infringement in its own name." *See, e.g., Sicom Sys., Ltd. v. Agilent Techs., Inc.*, 427 F.3d 971, 976 (Fed. Cir. 2005). It follows that if an effective patentee provides actual notice of the patent and the charge of infringement, the marking statute could have been satisfied. Mr. Aloush described iLeverage as Shiron's "exclusive agent," and Hughes has not met its summary judgment burden of establishing that iLeverage could not have been an effective patentee. A material fact issue as to the scope and extent of iLeverage's agency relationship exists. If iLeverage was effectively the patentee for purposes of standing, a reasonable juror could conclude that iLeverage provided actual notice of the '073 patent and the charge of infringement. The Court therefore **RECOMMENDS** Hughes' Marking Motion be denied.

6. Motion for Summary Judgment of Noninfringement of the '874 Patent (Dkt. 298)

Hughes moves for partial summary judgment of noninfringement of claims 2-5, 7-9, 11, and 12 of the '874 patent. Hughes explains that each of these claims depends from a claim requiring "conversion between two protocols," namely "E1" and "TCP/IP." Dkt. 298 at 1. According to Hughes, "[t]he third party devices provided by Hughes do not convert to or use TCP/IP for cellular backhaul under any circumstances." *Id.* "Instead, they use a different protocol known as UDP." *Id.* Thus, according to Hughes, "Elbit has no evidence of infringement of the dependent claims of the '874 patent." *Id.*

The Court does not agree. Both Elbit's and Hughes' technical experts agree that "TCP/IP refers to a suite of protocols that may be used to interconnect network devices on the Internet."

See Dkt. 321 at 5-6 (citing expert reports). On the basis of the summary judgment record, a reasonable juror could therefore conclude that UDP is a member of the TCP/IP family, and that if the accused products convert to the UDP protocol, they are encompassed by claims 2-5, 7-9, 11, and 12 of the '874 patent.

To the extent Hughes' motion for summary judgment is based on an untimely claim construction position regarding the meaning of "TCP/IP," as that term is used in the asserted claims, Hughes waived these arguments by not raising them earlier. *See, e.g., Cent. Admixture Pharmacy Servs., Inc. v. Advanced Cardiac Sols., P.C.*, 482 F.3d 1347, 1356 (Fed. Cir. 2007) ("The district court found that [defendants] waived any argument with respect to this term by failing to raise it during the claim construction phase. We agree."); *Fenner Inv., Ltd. v. Microsoft Corp.*, 632 F. Supp. 2d 627, 638 (E.D. Tex. 2009) ("Because this argument is contrary to the claim construction order and was not raised prior to or even following the claim construction hearing it is waived."), *aff'd sub nom. Fenner Investments, Ltd. v. Microsoft Corp.*, 369 F. App'x 132 (Fed. Cir. 2010). The Court therefore **RECOMMENDS** Hughes' Motion for Summary Judgment of Noninfringement of the '874 Patent be denied.

B. Motions to Strike or Exclude Contentions or Opinions

1. Elbit's Motion to Strike Invalidity Opinions (Dkt. 275)

Elbit asks the Court to strike the following two portions of Dr. Stephen Wicker's expert report: (1) prior art references previously struck by the Court because Hughes failed to disclose the references through invalidity contentions, namely U.S. Patent No. 5,978,386 ("Hämäläinen") and U.S. Patent No. 7,050,456 ("Sprague"); and (2) a prior art product known as "LANA*Advantage*" that Hughes allegedly failed to disclose through contentions. *See* Dkt. 275 at 1.

With respect to the first portion of Dr. Wicker’s report, Hughes argues there is no dispute, while Elbit contends otherwise. Hughes states it agreed, “it would not seek to present the Hämäläinen and Sprague references without first obtaining leave of Court” and that “that Elbit was not required to present an expert rebuttal for those references unless the Court grants Hughes leave to assert them.” Dkt. 286 at 1. Hughes therefore suggests that “there was no dispute on this issue at the time Elbit filed its motion to strike, nor is there any dispute now.” *Id.* Elbit’s reply brief nonetheless explains that Hughes’ position on the Hämäläinen and Sprague references is not as clear as Hughes would have the Court believe. Dkt. 290 at 1-2.

The Court previously struck the Hämäläinen and Sprague references from Hughes’ invalidity contentions because Hughes failed to timely disclose them or offer an adequate explanation for the delay. *See* Dkt. 242 at 1; Dkt. 249 (Hearing Transcript). Though it is unclear whether a dispute about these references exists, Dr. Wicker opines that claim 1 of the ’874 patent is obvious in view of a combination of references including Hämäläinen or Sprague. *See* Dkt. 275-2 at 1292, 1323. To clear the record and resolve any dispute that exists or that may arise, the Court **GRANTS** Elbit’s motion as to the Hämäläinen and Sprague references and **STRIKES** portions of Dr. Wicker’s report that rely on these references to demonstrate obviousness, specifically paragraphs 1,118-1,264. *See* Dkt. 275-2.

As for the second disputed portion of Dr. Wicker’s report, Elbit argues Dr. Wicker introduces a new invalidity theory relying on an undisclosed add-on to Hughes’ Personal Earth Station (“PES”) system prior art—the LAN*Advantage* feature—which allegedly provided Internet-related functionality to the PES. Dkt. 275 at 6. While the phrase “LAN*Advantage*” may not have appeared in Hughes’ invalidity contentions, Hughes disclosed that the PES included Transmission Control Protocol/Internet Protocol (TCP/IP) functionality, and Hughes cited the

corresponding source code. *See* Dkt. 286 at 1. Elbit demands granularity not required by the local patent rules. Because Hughes adequately disclosed PES's underlying functionality, the Court **DENIES** Elbit's motion as to the LAN*Advantage* feature.

2. Hughes' Motion to Strike Infringement Contentions (Dkt. 276)

Hughes moves to strike Elbit's infringement contentions regarding the '874 patent for failure to comply with Local Patent Rule 3-1. Dkt. 276 at 1. Hughes contends Elbit "invoked P.R. 3-1(g) for seven claim elements in the asserted claims" yet failed to comply with P.R. 3-1(g)'s requirement that source code corresponding to the claim element be identified 30 days after the opposing party produces the relevant code. *Id.*; Local Pat. R. 3-1(g) (included in Discovery Order, Dkt. 55 at 2-3). Elbit argues it fully complied with Local Patent Rule 3-1's requirements by timely serving infringement contentions with an element-by-element analysis and supporting documents, and Elbit merely reserved the right to supplement these contentions for software limitations after it received relevant source code.

Local Patent 3-1(g) has a clear purpose. The Rule affords a party alleging infringement an opportunity to delay compliance with Patent Rule 3-1's requirements for claim elements that may be satisfied by source code that has not yet been produced. After production of the source code, the party claiming infringement must update its infringement contentions by identifying the portions of the code that satisfy relevant claim elements within 30 days. The Rule does not, however, bind a party that refers to a claim element as a "software limitation" to later identify corresponding source code. The Rule merely gives the party a delayed option of doing so. If a party discloses how a "software limitation" is met without reference to source code, and the party's disclosure otherwise meets Local Patent Rule 3-1's requirements, there may be no need to later update infringement contentions with references to source code.

Elbit charted certain software limitations by identifying documents allegedly establishing the existence of the limitations in the accused system—without reference to third-party source code. *See* Dkt. 276-2. Elbit’s contentions also included the following statement:

Pursuant to the Court’s Discovery Order (Dkt. 55) and P.R. 3-1(g), Plaintiffs state on information and belief that further evidence for this limitation resides in the source code for the Accused Instrumentalities. Plaintiffs reserve the right to supplement after production of the source code for the Accused Instrumentalities.

See, e.g., id. at 7. Although Elbit reserved the right to supplement its contentions with later-produced source code, it had no obligation to do so simply because it identified claim elements as “software limitations” or because it believed at the time that further evidence for those limitations would exist in third-party source code. Because Elbit did not violate Rule 3-1(g), Hughes’ motion to strike is **DENIED**.

3. Hughes’ Priority Date Motion (Dkt. 277)

Hughes moves to exclude Elbit’s contention that asserted claims of the ’073 patent are entitled to a priority date earlier than the patent’s November 14, 1997 filing date. Dkt. No. 277 at 1. There have been prior disputes surrounding the ’073 patent’s priority date and Hughes’ interrogatory question concerning priority. *See* Dkt. 277 at 2-4. Suffice it to say that until January 2017, Elbit disclosed to Hughes and represented to the Court that the ’073 patent’s priority date is November 14, 1997—the filing date. *Id.* Elbit’s position changed on January 9, 2017, shortly before the close of fact discovery, when Elbit disclosed to Hughes that the ’073 patent is entitled to a priority date nine months earlier than the filing date—February 11, 1997—based on an earlier conception and reduction to practice. *See* Dkt. 277-2 at 9-11.

Elbit argues its change in position was justified. *See* Dkt. 288. According to Elbit, it changed its priority contention shortly after Hughes disclosed a new prior art system based on documents dated less than one year before the ’073 patent’s filing date. *See id.* at 1; 35 U.S.C.

§ 102(a). Elbit also argues its new position was not untimely under Rule 26(e)(1) because it was disclosed within the fact discovery period. *See* Dkt. 288 at 1.

Hughes' interrogatory understandably sought to commit Elbit to a priority date. The Local Patent Rules encourage a party claiming infringement to identify the priority date for asserted claims early in a case. *See* Local Patent Rule 3-1(e). In many instances, a party claiming infringement will possess facts supporting priority before bringing the lawsuit. Even when discovery reveals an unforeseen earlier priority date, there is rarely a justifiable excuse for shifting a priority date contention near the end of fact discovery.

Elbit's change in priority date was untimely under Rule 26(e)(1) because it is undisputed that Elbit possessed the underlying facts at least by September 2016. Yet Elbit did not update its interrogatory response until January 2017, nine days before fact discovery closed. Accordingly, the question is whether Elbit's untimely disclosure is harmless. *See CQ, Inc. v. TXU Min. Co., L.P.*, 565 F.3d 268, 280 (5th Cir. 2009) (considering "(1) [the party's] explanation for its failure to disclose the evidence, (2) the importance of the evidence, (3) the potential prejudice to [the opposing party] in allowing the evidence, and (4) the availability of a continuance").

Elbit does not adequately explain the delay. While Hughes may have supplemented an invalidity contention based on prior art documents dated less than one year before the '073 patent's filing date, Elbit had an incentive to trace the '073 patent's priority date to as far back as possible in light of other asserted prior art references allegedly made public in 1997. *See* Dkt. 277 at 8 n.2. Elbit has known about such references since January 2015. While Elbit's attempt to antedate a prior art defense is undoubtedly important, the prejudice to Hughes is significant. Hughes justifiably developed invalidity positions under the assumption that the '073 patent is entitled to a priority date no earlier than its filing date. Finally, any continuance would delay trial, which is

about a month away. *See S&W Enters., L.L.C. v. SouthTrust Bank of Ala., N.A.*, 315 F.3d 533, 537 (5th Cir. 2003) (affirming district court’s refusal to grant continuance when it would “unnecessarily delay the trial”). Elbit has therefore failed to show its discovery violation is harmless. *See Fed. R. Civ. P. 37(c)(1)* (If a party fails to provide information as required by Rule 26(e), “the party is not allowed to use that information . . . to supply evidence . . . at a trial, unless the failure was substantially justified or is harmless.”).

Hughes’ Priority Date Motion is **GRANTED**. Elbit may not present evidence or argue that the ’073 patent is entitled to a priority date earlier than its filing date, i.e., November 14, 1997. Additionally, Elbit is precluded from presenting evidence or argument that the inventors listed on the ’073 patent reduced the invention to practice earlier than November 14, 1997.

4. Plaintiffs’ Motion to Strike Non-Infringing Alternatives (Dkt. 315)

Elbit asks the Court to prevent Dr. Wicker and Mr. Bakewell from offering opinions on alleged noninfringing alternatives provided by iDirect, Iridium and Gilat. *See* Dkt. 315. According to Elbit, Dr. Wicker disclosed Defendants’ reliance on these noninfringing alternatives for the first time in his March 6, 2017 rebuttal report. *Id.* at 3. Mr. Bakewell in turn cites to Dr. Wicker’s noninfringing alternatives analysis in his report. *Id.*

Defendants do not dispute that the iDirect, Iridium and Gilat products were not disclosed during discovery. Rather, Defendants rely on a loophole in the Federal Rules governing responses to interrogatories. *See* Dkt. 329 at 2. Elbit served Hughes (and only Hughes) with one interrogatory related to non-infringing alternatives, and Hughes “respond[ed] to that interrogatory with the information available to Hughes.” *Id.* at 2. The iDirect, Iridium and Gilat products, however, are only sold by other Defendants, most notably BlueTide. *Id.* at 1. Hughes therefore contends information concerning these products was not available to Hughes, and because the other

Defendants were not served with the non-infringing alternatives interrogatory, Defendants were not obligated to disclose the iDirect, Iridium and Gilat products. *Id.* at 1-2.

The record nevertheless suggests that Hughes had knowledge of at least Gilat's "SkyEdge" product and the iDirect product. *See* Dkt. 353-1, 353-2. Deposition testimony reveals that BlueTide had little if any technical expertise necessary to understand whether the products it sells do or do not infringe the asserted claims. *See* Dkt. 353-3 at 263:3-18. Defendants' experts only state that they relied on other experts and one of Hughes' executives, and there is no mention of these experts' reliance on BlueTide documents or witnesses for any of the three products. *See* Dkt. 353 at 2-3.

Defendants therefore had an obligation to disclose the allegedly non-infringing iDirect, Iridium and Gilat products, and they failed to do so. The question is whether the violation is harmless. *See* Fed. R. Civ. P. 37(c)(1) (If a party fails to provide information as required by Rule 26(e), "the party is not allowed to use that information . . . to supply evidence . . . at a trial, unless the failure was substantially justified or is harmless."); *see also* *CQ*, 565 F.3d at 280 (considering "(1) [the party's] explanation for its failure to disclose the evidence, (2) the importance of the evidence, (3) the potential prejudice to [the opposing party] in allowing the evidence, and (4) the availability of a continuance").

Defendants' explanation for their failure to disclose the evidence is simply that Elbit did not ask each Defendant to answer the interrogatory about noninfringing alternatives. That explanation is not credible because the record suggests Hughes should be charged with knowledge of the iDirect, Iridium and Gilat products. "The rules governing discovery in federal court are designed to 'accomplish full disclosure of the facts, eliminate surprise, and promote settlement.'"

Moore v. Ford Motor Co., 755 F.3d 802, 808 (5th Cir. 2014) (quoting *S. Ry. Co. v. Lanham*, 403 F.2d 119, 127 (5th Cir. 1968)).

The importance of the opinions concerning the allegedly noninfringing iDirect, Iridium and Gilat products is minimal. Dr. Wicker provides little detail as to how these products meet the noninfringing alternative standard. Rather, Dr. Wicker explains that “Elbit has not accused the [products] of infringement and Mr. Elbert has not provided an opinion as to the infringement of the [products].” See Dkt. 315-3 ¶¶ 67-71. Such a conclusion is insufficient to establish a noninfringing alternative. *Droplets, Inc. v. Overstock.com, Inc.*, Case 2:11-cv-00401-JRG-RSP, Dkt. 347 at 3 (Jan. 9, 2015 E.D. Tex.) (expert “should be precluded from making the assertion that [products] are non-infringing alternatives simply because [the plaintiff] has not accused them of infringement.”). The possibility that Defendants could establish the iDirect, Iridium and Gilat products as noninfringing alternatives is therefore remote. See *Allergan, Inc. v. Teva Pharm. USA, Inc.*, No. 2:15-CV-1455-WCB, 2017 WL 1512334, at *5 (E.D. Tex. Apr. 27, 2017) (Bryson, J., sitting by designation) (“In determining the importance of the amendment, the Court must make a pragmatic judgment as to the likelihood that the newly asserted defense will succeed.”).

The potential prejudice to Elbit is significant because Defendants’ experts, if limited to their reports at trial, would simply present their conclusions that the iDirect, Iridium and Gilat products are noninfringing alternatives, largely because the products have not been accused of infringement. Elbit has not had a chance to test the underlying merits of these conclusions through discovery. Finally, any continuance would delay trial, which is about a month away. See *S&W Enters., L.L.C. v. SouthTrust Bank of Ala., N.A.*, 315 F.3d 533, 537 (5th Cir. 2003) (affirming district court’s refusal to grant continuance when it would “unnecessarily delay the trial”). Accordingly, Plaintiffs’ Motion to Strike Non-Infringing Alternatives is **GRANTED**.

Elbit does not identify which specific portions of Defendants' reports should be struck. It appears that paragraphs 67-71 of Dr. Wicker's report include opinions that the iDirect, Iridium and Gilat products are noninfringing alternatives. Accordingly, the Court **STRIKES** paragraphs 67-71 of Dr. Wicker's March 6, 2017 report. *See* Dkt. 315-3. Mr. Bakewell appears to reference Dr. Wicker's opinions in paragraphs 209, 214, and 357 (fifth bullet point only) in his March 6, 2017 rebuttal damages report. *See* Dkt. 315-4. The Court therefore **STRIKES** paragraphs 209, 214, and 357 (fifth bullet point only) from Mr. Bakewell's report.

5. Hughes' Motion to Strike Infringement Opinions (Dkt. 316)

Hughes moves to strike two theories of infringement allegedly undisclosed until Elbit served its expert reports: (1) functionality and source code in Hughes' accused HN/HX products allegedly corresponding to the "switching means" claim limitation; and (2) opinions regarding transmitter structure allegedly corresponding to the "first communication means." Dkt. 316 at 1-2.

With respect to the first theory, Hughes argues Richard Goodin's infringement report "marks the first instance of Elbit identifying that the HN/HX systems performed a comparison of an amount of data to the size of an Aloha burst and identifying that such functionality satisfied the 'switching means' claim limitation." *Id.* at 7. Elbit's December 2015 Contentions, however, disclose the relationship between the Aloha burst and the amount of data that can be transmitted: "If the Aloha logical channels are configured to be large enough, the remote terminal may be able to send a complete transaction within the Aloha burst, depending on the application." *See* Dkt. 337 at 3 (quoting P.R. 3-1 Contentions).

Hughes argues this disclosure is insufficient to provide notice of the theory as it relates to the "switching means" element because, according to Hughes, this disclosure relates to a different

“means for switching” element. *See* Dkt. 356 at 2. The claim limitation, however, recites a “switching means compris[ing] means for switching.” *See* Dkt. 363 at 1. Elbit’s December 2015 Contentions therefore provide adequate notice of the “switching means” theory described in Mr. Elbert’s expert report.

Hughes also complains that Elbit did not disclose the specific lines of source code underlying Elbit’s expert reports, i.e., that Elbit “abandoned” the original source code cited in its contentions in favor of new source code. *See* Dkt. 316 at 1. Elbit cites persuasive authority, however, explaining that as long as an infringement theory is adequately disclosed, every underlying item of proof (such as source code) does not need to be disclosed, provided the notice purpose of the local patent rules is satisfied through a disclosure of an infringement theory. *See Adobe Sys. Inc. v. Wowza Media Sys.*, No. 11-CV-02243-JST, 2014 WL 709865, at *16 (N.D. Cal. Feb. 23, 2014).

More important, however, Mr. Goodin testified during his deposition that the functionality of the source code cited in his report is consistent with the source code cited in Elbit’s infringement contentions. *See* Dkt. 337-4 at 123:10-23. According to Mr. Goodin, he chose the source code cited in his report simply because “it was just in one place in two functions versus being distributed a little more, you know, across multiple files or across multiple areas of a single file.” *Id.* at 123:14-17. Finally, Hughes has articulated its substantive disagreements with Mr. Goodin’s theory (and moved for summary judgment on that theory, *see* Dkt. 291) suggesting any prejudice is minimal. *See SSL Services, LLC v. Cisco Sys., Inc.*, Case No. 2:15-cv-433-JRG-RSP (E.D. Tex. Feb. 24, 2016).

The remaining prejudice Hughes identifies does not persuade the Court that any discovery violation that may have occurred warrants correction. Hughes contends that if it had been on notice

of Elbit’s new “switching means” theory, it could have identified comparable source code in the Aloha processor module in its prior art Personal Earth Station system. *See* Dkt. 316 at 10. Hughes was aware of the Court’s claim constructions when it developed its invalidity position, however, and Hughes knew as much about the scope of the claims as Elbit did. Hughes also had the source code for the Personal Earth Station system. *See id.* It is not clear why Elbit’s infringement theory should match Hughes’ invalidity theory. Hughes’ motion as to the “switching means” theory is therefore **DENIED**.

With respect to the second allegedly undisclosed theory, the Court determined during claim construction that the “first communication means” recited in the ’073 patent claims is governed by § 112, ¶ 6 and that the corresponding structure is “the random access transmitter as depicted in Figure 5 in its entirety.” *See* Dkt. 208 at 11, 14.

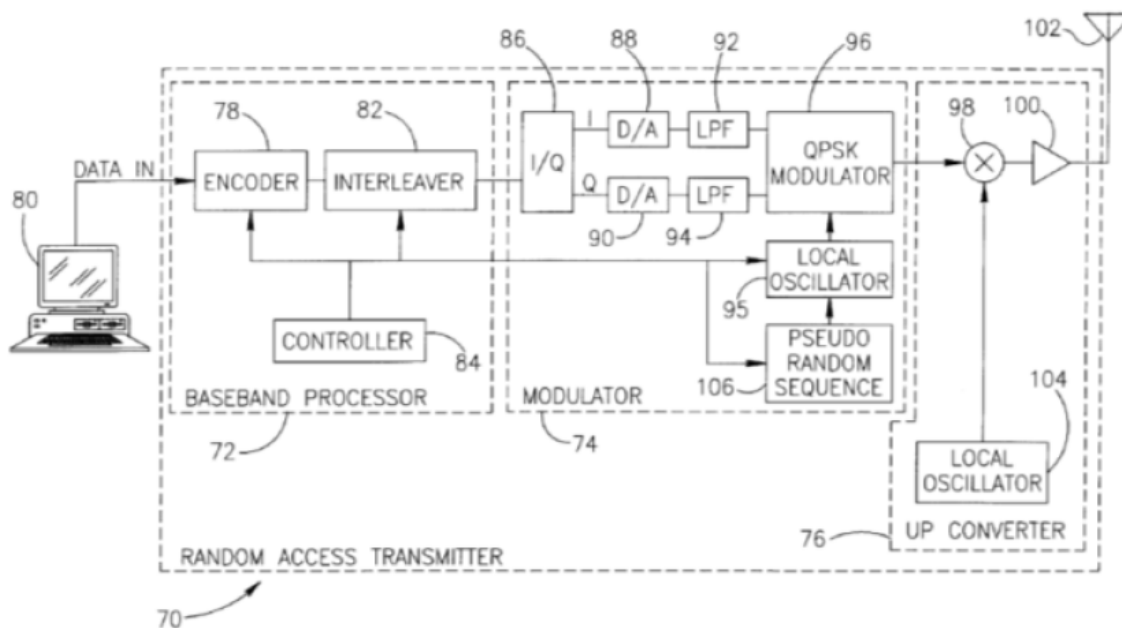

FIG. 5

Hughes argues that Elbit’s infringement contentions “did not map the structure identified in the Court’s claim construction order (‘Figure 5 in its entirety’) to any Hughes product structure.” Dkt.

316 at 12. Rather, according to Hughes, Elbit’s infringement contentions “identify only a ‘High-Level Inroute IpoS Diagram” with “no discussion of the depicted components, or how any of the components in this high-level figure correspond to the required structure for the ‘first communication means.’” *Id.*

Local Patent Rule 3-1(c) requires a party alleging infringement to identify “where each element of each asserted claim is found within each Accused Instrumentality, including for each element that such party contends is governed by 35 U.S.C. § 112(6), the identity of the structure(s), act(s), or material(s) in the Accused Instrumentality that performs the claimed function.” Consistent with that standard, Elbit’s contentions identify a diagram depicting a number of structural components, including an encoder, scrambler, and “16-bit CRC,” among others. *See* Dkt. 337 at 8 (citing P.R. 3-1 Contentions). Hughes’ argument is simply that more detail or explanation should have been included, but “the preparation and supplementation of infringement contentions is a matter of pleading and merely notifies a defendant of the asserted theories of infringement in order to provide adequate notice and streamline discovery.” *See Realtime Data, LLC v. Packeteer, Inc.*, No. 6:08CV144, 2009 WL 2590101, at *5 (E.D. Tex. Aug. 18, 2009).

To the extent Hughes’ argument rests on the assumption that a party alleging infringement must map each structural component corresponding to a “means” limitation to an accused component, the Court disagrees that such a requirement exists. “The individual components, if any, of an overall structure that corresponds to the claimed function are not claim limitations.” *Odetics, Inc. v. Storage Technology Corp.*, 185 F.3d 1259, 1268 (Fed. Cir. 1999). “Rather, the claim limitation is the overall structure corresponding to the claimed function. This is why structures with different numbers of parts may still be equivalent under § 112, ¶ 6, thereby meeting the claim limitation.” *Id.*

It is true, as Hughes points out, that the Court rejected Elbit's argument during claim construction that Figure 5 without any sub-components (an "empty box" as Hughes characterizes it) could constitute structure corresponding to the "first communication means." *See* Dkt. 208 at 14. But it is unclear how this should affect Hughes' infringement contentions or what decision Elbit should be "forced to live with," *see* Dkt. 316 at 11. Elbit unsuccessfully argued for a broad category of structure corresponding to the "first communication means." Elbit is not thereafter precluded from detailing how components in a diagram disclosed through infringement contentions correspond to the structure of the "first communication means." Hughes' motion as to the "first communication means" theory is therefore **DENIED**.

C. *Daubert* Motions

Both Elbit and Defendants challenge each others' expert testimony under Federal Rule of Evidence 702. When evaluating a party's challenge to an opponent's expert witness, the Court assumes the role of gatekeeper to ensure the reliability and relevance of the expert's testimony. *Daubert v. Merrell Dow Pharm., Inc.*, 509 U.S. 579, 597 (1993); *Kumho Tire Co. v. Carmichael*, 526 U.S. 137, 150 (1999). Rule 702 guides the inquiry, specifying that a qualified expert may testify as long as his opinion will aid the fact finder and is reliable, i.e., the opinion must stand on sufficient data, reliable methods, and the facts of the case. *See Daubert*, 509 U.S. at 590; Fed. R. Evid. 702(a)-(d); *see also Micro Chem., Inc. v. Lextron, Inc.*, 317 F.3d 1387, 1391 (Fed. Cir. 2003) ("In 2000, Rule 702 was amended in response to *Daubert* and cases applying it.").

1. Elbit's Infringement Expert Motion (Dkt. 312)

Elbit moves to exclude four portions of Dr. Wicker's testimony. First, Elbit argues Dr. Wicker's opinions that the PES prior art system anticipates the '073 patent claims are unreliable because Dr. Wicker allegedly concedes the PES system does not include every element

of the asserted claims. Elbit's complaint appears to be that Dr. Wicker's opinions rely on a comparison between the accused products and the prior art PES system.

With respect to the claimed "first communications means," Dr. Wicker includes opinions that rest on a factual analysis of the allegedly prior PES system, as compared to the asserted claims. *See* Dkt. 327-2 ¶ 230. The same is true for the claimed "second communication means." *See id.* ¶ 248. While Dr. Wicker's report does make comparisons between the PES system and the accused products, there is enough standalone factual basis for Dr. Wicker's opinions to withstand exclusion under Rule 702. *See Verizon Servs. Corp. v. Cox Fibernet Virginia, Inc.*, 602 F.3d 1325, 1339 (Fed. Cir. 2010) ("[A] reasonable jury could conclude, based on evidence in the record and separate and apart from any alleged 'practicing the prior art' argument, that the Feature Patents were invalid.").

Second, Elbit argues Dr. Wicker's invalidity opinions are unreliable because Dr. Wicker used the broadest reasonable construction for a claim term in a manner that is inconsistent with the *Phillips* standard. *See* Dkt. 312 at 1. Elbit's objection is based on a typographical error or oversight in Dr. Wicker's report. Dr. Wicker clarified in deposition that he "was using what one of ordinary skill at the time of the invention would have understood the claims to mean, which would be within the broadest reasonable interpretation, but it would be narrower than that." *See* Dkt. 327-3 at 430:3-8. Dr. Wicker will not be permitted to testify about a claim term's broadest reasonable interpretation, regardless of what his expert report says, and it does not appear that he intends to do so.

Third, Elbit contends Dr. Wicker's opinions describing noninfringing alternatives should be excluded. According to Elbit, Dr. Wicker provided no factual basis or analysis for his noninfringing alternatives opinions. *See* Dkt. 312 at 1-2. Hughes contends that Dr. Wicker intends

to support this opinions at trial by pointing to testimony from live fact witnesses. Dr. Wicker cites relevant deposition testimony in his report, and there is no dispute that an expert may rely on fact testimony presented at trial. For these reasons, Elbit's Infringement Expert Motion is **DENIED** (Subject to the Court's ruling on Plaintiffs' Motion to Strike Non-Infringing Alternatives, Dkt. 315).

2. Hughes' Motion to Exclude Patent Office Expert Testimony (Dkt. 313)

Hughes asks the Court to exclude certain opinions of Elbit's patent office practice and procedure expert, Stephen Kunin, because Hughes contends that some of his opinions are "not relevant to any issue in the case and are based on unreliable methodologies." Dkt. 313 at 1. First, Hughes argues "Mr. Kunin improperly opines regarding [the prosecuting attorney's] supposed state of mind and knowledge of the '073 patent, and actions Mr. Plastrik must have taken in responding to an office action." *Id.*

Mr. Kunin's testimony emphasizes that Elbit's '073 patent was cited as prior art to one of Hughes' patent applications. *See, e.g.*, Dkt. 313-1 ¶¶ 37-48. Mr. Kunin includes an analysis of the prosecution of Hughes' patent application, including Mr. Kunin's assertion that the prosecuting attorney, "in order to distinguish [the '073 patent] disclosure from the limitations set forth in the then pending claims of the '755 application," "would have had to review the '073 patent to reach the conclusion that it 'does not teach or suggest the feature of a network control cluster" *Id.* ¶ 44.

Whatever relevance this testimony might have, the Court agrees with Hughes that the testimony does not satisfy the *Daubert* standard. Mr. Kunin does not have personal knowledge of what Hughes' prosecuting attorney may or may not have necessarily done to prosecute Hughes' patent application. *See Daubert*, 509 U.S. at 599, 113 S.Ct. 2786 (requiring more than "subjective

belief or unsupported speculation” from expert testimony). Nor would Mr. Kunin’s testimony be relevant or helpful to the trier of fact. *See Daubert*, 509 U.S. at 595 (trial court must ensure “that an expert’s testimony both rests on a reliable foundation and is relevant to the task at hand”). Accordingly, Mr. Kunin will not be permitted to testify about what Hughes’ prosecuting attorney “would have had to review” as part of prosecuting Hughes’ patent application. *See* Dkt. 313-1 ¶¶ 44, 45, 48.

Second, Hughes contends Mr. Kunin’s opinion that the ’073 patent is “foundational” should be excluded. *See* Dkt. 313 at 1-2. Mr. Kunin characterizes the ’073 patent as “foundational” because the patent was cited as prior art during the prosecution of “at least three Hughes patent applications,” “has been applied by the Examiners as anticipatory prior art to then pending claims in at least the ’755 Hughes patent application,” and has been cited “in 52 United States patents.” Dkt. 313-1 ¶¶ 55-56. These facts, according to Mr. Kunin “is an indicator of the foundational nature of a patent.” *Id.* ¶ 58.

The Court agrees with Hughes that Mr. Kunin’s testimony does not meet the *Daubert* standard. Mr. Kunin cites two studies reporting the mean and median number of patent citations, and Mr. Kunin compares these mean and median citation numbers with the number of times the ’073 patent has been cited. Even assuming these studies compel a statistically significant conclusion, it is not clear how the number of times a patent is cited renders the patent “foundational.” *See* Dkt. 313-1 ¶ 62 n. 12. Indeed, Mr. Kunin’s testimony suggests that a patent may be cited by Examiners more frequently if the patent has a “a large omnibus specification.” *Id.* ¶ 59. An omnibus specification of course has nothing to do with the technical merits of a patent specification or the patentability of its claims. *See Sundance, Inv. v. DeMonte Fabricating Ltd.*, 550 F.3d 1356, 1361-62 (Fed. Cir. 2008) (reversing trial court for erroneously permitting a patent

prosecution expert to testify on the technical merits of a patent in suit). Moreover, the term “foundational” is not clearly defined by Mr. Kunin and thus unhelpful to the jury.

Nor is it clear what relevance, if any, Mr. Kunin’s testimony about the supposedly foundational nature of the ’073 patent has to the questions the jury will be required to resolve. *See Daubert*, 509 U.S. at 595 (trial court must ensure “that an expert’s testimony both rests on a reliable foundation and is relevant to the task at hand”). In sum, Mr. Kunin’s testimony about the foundational nature of the ’073 patent will not assist the trier of fact. *See id.* Accordingly, Mr. Kunin’s testimony based on paragraphs 55 through 62 of his expert report is excluded. *See* Dkt. 313-1. 2. Hughes’ Motion to Exclude Patent Office Expert Testimony is therefore **GRANTED**.

3. Defendants’ Motion to Exclude Damages Expert Testimony (Dkt. 314)

Hughes moves to exclude opinions by Elbit’s expert, Mr. Martinez, related to: (1) his royalty analysis for the ’073 Patent that relies on an allegedly non-comparable settlement agreement and fails to apportion value to the claimed invention; (2) his lost profits analysis for the ’073 patent that allegedly fails to consider non-infringing alternatives; and (3) his damages opinion with respect to the ’874 patent in view of his failure to separately calculate damages for this patent. *See* Dkt. 314.

The parties’ arguments about Mr. Martinez’s royalty and apportionment analysis are less about reliability and more about credibility, i.e., they raise questions for the jury to resolve. The parties do not dispute that the patents-in-suit have not been licensed before. Dkt. 331 at 2-3. Mr. Martinez opines that the Gilat license is comparable, while Hughes’ expert opines that the Caltech license is comparable. *Id.*

The Gilat License resulted from a lawsuit Hughes brought against a competitor in the satellite communication industry for infringing patents related to Hughes' one-way DirecPC systems, i.e., technology that preceded Hughes' allegedly infringing two-way systems. Dkt. 331-1 ¶¶ 207-39. Defendants highlight differences between the Gilat License and the hypothetical negotiation involving the patents-in-suit, but comparable licenses need not be identical as long as they are "sufficiently comparable to the hypothetical license at issue in suit." *Lucent Techs., Inc. v. Gateways, Inc.*, 580 F.3d 1301, 1325, 1328-30 (Fed. Cir. 2009). An expert may rely on past licenses involving different technology as long as the expert "account[s] for differences in the technologies and economic circumstances of the contracting parties." *Virnetx, Inc. v. Cisco Sys., Inc.*, 767 F.3d 1308, 1330 (Fed. Cir. 2014). Mr. Martinez's report adequately accounts for such differences. *See* Dkt. 331-1 ¶¶ 207-39.

Moreover, Mr. Martinez's explanation of the differences between the accused technology and the technology subject to the Gilat license adequately accounts for his apportionment of the value of the patents-in-suit. *See id.* ¶¶ 208-224, 228-235, 238-239, 267-273. "[E]stimating a reasonable royalty and apportionment is never an exact science. At some level an expert must be allowed to rely on and use his or her judgment, provided the opinion is supported by facts and data." *PerdiemCo, LLC v. Industrack LLC*, No. 2:15-CV-726-JRG-RSP, 2016 WL 6611488, at *3 (E.D. Tex. Nov. 9, 2016). Mr. Martinez's opinion is not so opaque as to be immune from rigorous cross-examination, the "traditional and appropriate means of attacking shaky but admissible evidence." *See Daubert*, 509 U.S. at 596.

Hughes' objection to Mr. Martinez's lost profits opinion is based on Mr. Martinez's alleged failure to consider noninfringing alternatives. *See, e.g.*, Dkt. 314 at 4-5. The parties' arguments concerning lost profits reveal a complex disagreement about what is required to establish lost

profits. Mr. Martinez's opinion accounts for the existence and effect of noninfringing alternatives, assuming those alternatives exist (which is a factual dispute for the jury to resolve) by conducting a market share apportionment analysis. *See* Dkt. 331-1 ¶¶ 276-92. Mr. Martinez's report also accounts for the possibility that certain alternatives are not satisfactory noninfringing alternatives. *See* Dkt. 331-1 ¶¶ 161-77.

Mr. Martinez's opinion is consistent with Federal Circuit authority. Indeed, as the Federal Circuit explained in *State Indus., Inc. v. Mor-Flo Industries, Inc.*, calculating lost profits in a multiple-competitor environment is difficult, but not impossible:

Frequently, the patent owner and infringer are the only suppliers in the market, and the owner is seeking to recover profits lost through every sale made by the infringer. In the two-supplier market, it is reasonable to assume, provided the patent owner has the manufacturing and marketing capabilities, that it would have made the infringer's sales. In these instances, the *Panduit* test is usually straightforward and dispositive.

Here we have multiple competitors and the patent owner contends that all the competitors infringed or sold a far less preferable alternative—fiberglass. The district court made the absence of acceptable substitutes, *Panduit* item (2), a neutral factor by crediting all the other competitors with their market shares as State requested. If the court is correct in its finding that the other competitors were likely infringers of one or the other of State's patents, State would have been entitled to their shares of the market on top of its own, and a correspondingly greater share of Mor-Flo's sales. If it is wrong in whole or in part, State would have been entitled to its current share or to a lesser increase in share. We need not decide which it is because it would make no difference to the outcome. State would get at least what it asked for, because as discussed further below the district court found, and we agree, that State's share of the market was proven.

883 F.2d 1573, 1578 (Fed. Cir. 1989) (citations omitted). Because Mr. Martinez's opinion is based on a market share approach similar to that described in *Mor-Flo*, the opinion does not violate *Daubert* and Rule 702.

Hughes' complaint with Mr. Martinez's opinion concerning compensation for the alleged infringement of the '874 patent is based on Mr. Martinez's lack of a separate royalty opinion for the '874 patent. *See* Dkt. 294; Dkt. 314 at 14-15. Hughes fails to adequately demonstrate why Mr. Martinez's opinion that the parties would have engaged in a single hypothetical negotiation for both asserted patents is unreliable simply because the '874 patent had not yet issued. Mr. Martinez's opinions satisfy the *Daubert* standard. *See, e.g., Comcast IP Holdings I LLC v. Sprint Commc'ns Co., L.P.*, 850 F.3d 1302 (Fed. Cir. 2017) (“[a] hypothetical negotiation in 2006 would include each of the asserted patents, even if they issued later, and the resulting negotiation would include the fact that two of the patents issued later.”). For these reasons, Defendants' Motion to Exclude Damages Expert Testimony is **DENIED**.

4. Elbit's Motion to Exclude Damages Expert Testimony (Dkt. 319)

Elbit asks the Court to strike five portions of Mr. Bakewell's report, namely opinions concerning: (1) “standard essential patents” (SEPs) and the related requirement to license such patents on fair, reasonable, and nondiscriminatory (FRAND) terms because, according to Elbit, the asserted patents are not SEPs and Elbit is under no FRAND obligations; (2) market approach royalty calculations based on a valuation by third party iLeverage; (3) an allegedly arbitrary royalty baseline; (4) third party patent licenses that Mr. Bakewell allegedly fails to establish are comparable; and (5) non-infringing alternatives for which Mr. Bakewell allegedly cites no evidence of their availability at the time of the hypothetical negotiation. *See* Dkt. 319.

The Court concludes that Elbit's objections to Mr. Bakewell's opinions go more toward the weight of his testimony than to its admissibility. With respect to Mr. Bakewell's SEP opinions, the parties dispute whether the patents-in-suit, notably the '073 patent, are SEPs. Mr. Bakewell contends at least the '073 patent is a SEP because it includes a claim that is “necessarily infringed”

by a system that utilizes technology incorporated into the IPoS standard. *See* Dkt. 346 at 1. Elbit emphasizes the lack of noninfringing alternatives for the accused Hughes products that practice the IPoS standard, and thus Mr. Bakewell's SEP analysis is at least supported by the possible conclusion that the '073 patent is essential to the IPoS standard. *See In re Innovatio IP Ventures, LLC Patent Litig.*, 956 F. Supp. 2d 925, 939 n.5 (N.D. Ill. 2013) ("If there are no commercially and technically feasible non-infringing alternatives, a claim is necessary. Similarly, if a claim is necessary, it means that there are no feasible alternatives with which to implement the standard."). Elbit argues Mr. Bakewell's discussions of FRAND obligations would confuse the jury, but this argument goes more to whether his testimony should be excluded under Rule 403, not Rule 702. Cross-examination is the "traditional and appropriate means of attacking shaky but admissible evidence." *See Daubert*, 509 U.S. at 596.

Elbit's objection to Mr. Bakewell's reliance on the iLeverage valuation is more of a disagreement about the reasonableness of Mr. Bakewell's valuation. Mr. Bakewell's iLeverage valuation opinions are not so unreliable as to warrant exclusion under *Daubert* and Rule 702. There are numerous factual disputes underlying Mr. Bakewell's iLeverage valuation, *see* Dkt. 346 at 4-7, and Elbit's objection goes to the weight of Mr. Bakewell's testimony, not its admissibility. *See Robocast, Inc. v. Microsoft Corp.*, No. 10-1055-RGA, 2014 WL 202399, *2-3 (D. Del. January 16, 2014) (declining to exclude valuation relied upon by expert because "it is up to the jury to determine the weight accorded the valuation").

Similarly, Elbit disagrees with Mr. Bakewell's royalty baseline, his reliance on the allegedly comparable Caltech license, and his discussion of noninfringing alternatives, but Mr. Bakewell's economic analysis is sufficiently detailed to avoid exclusion under *Daubert*. As for the royalty baseline, Mr. Bakewell provides a range of values derived from economic analysis,

see, e.g. Dkt. 346-1 ¶¶ 358, 364, 368, 486, 488, and this range can be tested through cross-examination. *See Summit6, LLC v. Samsung Elecs. Co., Ltd.*, 802 F.3d 1283, 1299 (Fed. Cir. 2015) (“[D]isputes over the expert’s credibility or over the accuracy of the underlying facts are for the jury”). As for the Caltech license, the real dispute is whether the license is sufficiently comparable, and thus the weight of Mr. Bakewell’s testimony is at issue, at least when the Court is satisfied that the allegedly comparable license bears a sufficient technological relationship to the patented technology, as is the case here. *See Ericsson, Inc. v. D-Link Sys., Inc.*, 773 F.3d 1201, 1227 (Fed. Cir. 2014) (“[T]hat a license is not perfectly analogous generally goes to the weight of the evidence, not its admissibility.”).

Finally, as for Mr. Bakewell’s discussion of noninfringing alternatives, the dispute is one that will be resolved by the jury when they determine which alternatives, if any, are adequate noninfringing substitutes, and what affect that may have on any damages award, *see* Dkt. 346-1 ¶ 203, 358, subject to the Court’s ruling on Plaintiff’s Motion to Strike Non-Infringing Alternatives (Dkt. 315). For these reasons, Elbit’s Motion to Exclude Damages Expert Testimony is **DENIED**.

D. Defendants’ Motions to Transfer and Stay (Dkts. 372 and 373)

Hughes and BlueTide move to transfer the case under 28 U.S.C. § 1406(a), contending that venue is improper in this district in view of the Supreme Court’s recent decision in *TC Heartland LLC v. Kraft Foods Group Brands LLC*, 137 S. Ct. 1514 (2017)—a decision that reaffirmed the Supreme Court’s 1957 holding that 28 U.S.C. § 1400(b) is the “sole and exclusive provision controlling venue in patent infringement actions.” *See Fourco Glass Co. v. Transmirra Prod. Corp.*, 353 U.S. 222, 229. *TC Heartland* clarified that venue is proper under § 1400(b) “in the judicial district where the defendant resides, or where the defendant has committed acts of infringement and has a regular and established place of business,” and that the term “resides” refers

“only to the State of incorporation.” *TC Heartland*, 137 S. Ct. at 1521. Hughes and BlueTide¹ contend they are not incorporated in Texas and have no regular and established place of business in the district. Elbit disputes whether Hughes waived objections to venue and whether venue over Hughes is proper on the merits. *See* Dkt. 386. The Court need not address the merits because Hughes and BlueTide waived their venue defense or objection to venue under Federal Rules of Civil Procedure 12(g)(2) and 12(h)(1)(A).

1. Relevant Procedural Background

In response to Elbit’s initial complaint, Hughes filed a motion to dismiss under Rule 12(b)(6), asking the Court to dismiss Elbit’s claims for willful patent infringement. *See* Dkt. 22. Hughes made no assertion that venue was improper. *See id.* Hughes renewed its motion on April 20, 2015, and again on December 14, 2015, in response to Elbit’s amended complaints. *See* Dkt. 34; Dkt. 69. Hughes’ renewed motions made no claim of improper venue. In Hughes’ answer to the complaint filed on April 13, 2016, Hughes stated that it “does not contest that venue is proper for Hughes in this District” but that Hughes “reserves the right to contest that venue is proper in this District based on *In re TC Heartland*, Case No. 16-0105, currently pending before the Federal Circuit. . . .” Dkt. 110 at 3. Hughes later filed a sealed document requesting transfer under 28 U.S.C. § 1404(a), arguing that venue would be more convenient in the District of Maryland. *See* Dkt. 130 at 5. Notably, the sealed document makes no mention of transfer under § 1406(a), which is the appropriate provision for requesting transfer of a case “laying venue in the wrong division or district.” *See* § 1406(a).

¹ Elbit responded to Defendants’ motion to transfer by stating it does not oppose “the Court dismissing the action against BlueTide on venue grounds at this time.” Dkt. 386 at 1. The Court declines to do so without a joint motion to dismiss BlueTide. Elbit also requests “that the Court exercise its power to dismiss Country Home under Rule 41(a)(2).” *Id.* at 1 n.1. The Court will consider Elbit’s request if Elbit or the parties file a motion to dismiss Country Home.

For its part, BlueTide filed a motion to dismiss for improper venue on March 16, 2015, acknowledging the existing Federal Circuit precedent holding that § 1391(c) supplements § 1400(b), and thus, according to that Circuit precedent, venue is proper in a patent case where a defendant is subject to personal jurisdiction. *See VE Holding Corp. v. Johnson Gas Appliance Co.*, 917 F.2d 1574, 1584 (Fed. Cir. 1990). Indeed, BlueTide stated in its motion that “[a] corporate defendant is deemed to reside for purposes of venue ‘in any judicial district in which such defendant is subject to the court’s personal jurisdiction with respect to the civil action in question.’” Dkt. 23 at 2 (quoting § 1391(c)(2)). The remainder of BlueTide’s motion assumes § 1391(c)(2) applied to this case and to patent cases generally. BlueTide’s objection was based solely on the argument that this district did not have personal jurisdiction over BlueTide (assuming the district was a state under § 1391(c)(2)). *See id.* at 3-9. The same assumption held in BlueTide’s second and third motions to dismiss for improper venue filed on April 20, 2015, and on December 14, 2015, both in response to Elbit’s amended complaints. *See* Dkt. 35 at 3; Dkt. 67 at 3. In BlueTide’s answer filed on April 13, 2016, BlueTide again denied that venue is proper, but for the first time stated that it “reserves the right to contest that venue is proper in this District based on *In re TC Heartland*, Case No. 16-0105, currently pending before the Federal Circuit.” *See* Dkt. 111 ¶ 10.

In sum, neither Hughes nor BlueTide affirmatively sought dismissal or transfer because of the lack of “resid[ence]” or the lack of a “regular and established place of business” under § 1400(b) as interpreted by *Fourco*, 353 U.S. at 229, until June 3, 2017—less than two months from trial. *See* Dkt. 351 (Docket Control Order); Dkt. 372.

2. Waiver of Venue Defense

“A party waives any defense listed in Rule 12(b)(2)-(5) by . . . omitting it from a motion in the circumstances described in Rule 12(g)(2).” Fed. R. Civ. P. 12(h)(1)(A). Under Rule 12(g)(2),

“a party that makes a motion under this rule must not make another motion under this rule raising a defense or objection that was available to the party but omitted from its earlier motion.” Rules 12(h)(2) and (3) exempt certain defenses from Rule 12(g)(2)’s consolidation requirement, including “[f]ailure to state a claim upon which relief can be granted,” failure “to join a person required by Rule 19(b),” failure “state a legal defense to a claim,” and lack of subject-matter jurisdiction. *See, e.g., Nationwide Bi-Weekly Admin., Inc. v. Belo Corp.*, 512 F.3d 137, 141 (5th Cir. 2007) (discussing Rule 12(h)(2)’s exemption of a motion for failure to state a claim from Rule 12(g)’s consolidation requirement); *see also Doe v. Columbia-Brazoria Indep. Sch. Dist. by & through Bd. of Trustees*, 855 F.3d 681, 687 (5th Cir. 2017). Rule 12(g)(2) does not exempt a venue defense or objection to venue under Rule 12(b)(3). *See Albany Ins. Co. v. Almacenadora Somex, S.A.*, 5 F.3d 907, 909 (5th Cir. 1993).

Thus, by filing a motion to dismiss for failure to state a claim under Rule 12(b)(6) and omitting its venue defense, Hughes waived the defense—assuming that defense “was available” to Hughes at the time. *See Fed. R. Civ. P. 12(g)(2), 12(h)(1)(A)*. Rule 12(g)(2) (and by extension Rule 12(h)(1)(A)) applies only to defenses or objections that were “available to the party.” Fed. R. Civ. P. 12(g)(2). Consistent with the text of the Rule and its applicability to “available” defenses and objections, courts in this Circuit recognize that waiver under Rule 12(h)(1)(A) does not apply to personal defenses that were unavailable to the party when waiver would have otherwise occurred. *See, e.g., Peacock v. Ins. & Bonds Agency of Texas, PLLC*, No. 3:12-CV-1710-D, 2012 WL 3702920, at *1 (N.D. Tex. Aug. 28, 2012).

Hughes and BlueTide argue the defense was unavailable because *TC Heartland* is an intervening change in law. Dkt. 372 at 14 n.4 (citing *Holzager v. Valley Hop.*, 646 F.2d 792, 796 (2d Cir. 1981)). The Court need not reach Defendants’ argument that a change in law constitutes

an exception to waiver under Rule 12(h)(1)(A) because the Supreme Court’s decision in *TC Heartland* does not qualify. *Fourco* was decided in 1957. While the Federal Circuit’s decision in *VE Holding* was inconsistent with *Fourco*, the Federal Circuit cannot overturn Supreme Court precedent. See *Thurston Motor Lines, Inc. v. Jordan K. Rand, Ltd.*, 460 U.S. 533, 535 (1983) (“Needless to say, only this Court may overrule one of its precedents.”). As one court in the Eastern District of Virginia concluded, “*TC Heartland* does not qualify for the intervening law exception to waiver because it merely affirms the viability of *Fourco*.” *Cobalt Boats, LLC v. Sea Ray Boats, Inc.*, No. 2:15-CV-21, 2017 WL 2556679, at *3 (E.D. Va. June 7, 2017).²

Hughes argues “it was well known that any motion under § 1400(b) suggesting that proper venue required either incorporation within the state of Texas or ‘a regular and established place of business’ by the defendant would be viewed as meritless.” Dkt. 372 at 14 n.4. While such a motion might have been viewed as meritless in a lower court, that does not change the harsh reality that Hughes would have ultimately succeeded in convincing the Supreme Court to reaffirm *Fourco*, just as the petitioner in *TC Heartland* did. See *Cobalt Boats*, 2017 WL 2556679, at *3. The Supreme Court’s decision in *TC Heartland* does not exempt Hughes from the waiver that occurred when Hughes left the venue defense out of its motion to dismiss for failure to state a claim. See Fed. R. Civ. P. 12(g)(2), 12(h)(1)(A).

Furthermore, Hughes waived its venue defense in its answer to Elbit’s complaint filed on April 13, 2016, by stating that it “does not contest that venue is proper for Hughes in this District” See Dkt. 110 at 3. Hughes has “fallen victim to the well-settled rule that a party is

² After the decision in *Cobalt Boats*, the defendant petitioned for writ of mandamus, and the Federal Circuit denied the petition “[u]nder the circumstances” and “on the eve of trial,” over Judge Newman’s dissent. See *In re Sea Ray Boats, Inc.*, Case No. 2017-124, Dkt. 15, Slip Op. at 2 (Fed. Cir. June 9, 2017). This Court confronts similar circumstances with trial on the horizon.

bound by what it states in its pleadings.” *See Soo Line R. Co. v. St. Louis Sw. Ry. Co.*, 125 F.3d 481, 483 (7th Cir. 1997); *see also Sunday Riley Modern Skin Care, L.L.C. v. Maesa*, No. CIV.A. H-12-1650, 2014 WL 722870, at *6 (S.D. Tex. Feb. 20, 2014). Hughes argues that Defendants “each expressly reserved their rights to challenge venue in the event *TC Heartland* changed the law,” *see* Dkt. 372 at 14 n.4; Dkt. 110 at 3, but a defendant cannot state that it does not dispute venue while reserving the ability to later contest it. To conclude otherwise would undermine the purpose of Rule 12(g) and (h) to promote efficiency and finality. *See Tiernan v. Dunn*, 295 F. Supp. 1253, 1256 (D.R.I. 1969) (“To permit this defense to be raised now would undermine the very purpose of Rule 12(g), (h), which is the avoidance of time-consuming, piece-meal litigation of pre-trial motions.”). A party’s conduct in the course of a proceeding can justify waiver even when the requirements of Rule 12(h)(1) are not satisfied. *See, e.g., Yeldell v. Tutt*, 913 F.2d 533, 539 (8th Cir. 1990) (“A delay in challenging personal jurisdiction *by motion to dismiss* has resulted in waiver, even where, as here, the defense was asserted in a timely answer.”) (emphasis added).

Unlike Hughes, BlueTide has consistently denied that venue is proper in the district, and BlueTide has filed three motions articulating its arguments. *See* Dkts. 23, 35, 67. Yet in each of these motions, BlueTide acknowledged the applicability of § 1391(c) to patent cases, a position that is not and never was controlling Supreme Court law, at least not since 1957—notwithstanding the fact that lower courts may have been bound by *VE Holding*. *See TC Heartland*, 137 S. Ct. at 1520 (“In *Fourco*, this Court definitively and unambiguously held that the word ‘reside[nce]’ in § 1400(b) has a particular meaning as applied to domestic corporations: It refers only to the State of incorporation.”).

By filing motions to dismiss for improper venue and omitting its objection to venue under § 1400(b)—as that provision was interpreted by *Fourco*—BlueTide waived its objection under

Rule 12(g)(2) and 12(h)(1)(A). BlueTide raised the *defense* of improper venue, but Rule 12(g)(2)'s consolidation requirement, and hence Rule 12(h)(1)(A) waiver, is not limited to a "defense." The Rule requires a party to include "a defense *or objection* that was available to the party." Fed. R. Civ. P. 12(g)(2) (emphasis added); *see also Albany Ins. Co.*, 5 F.3d at 909-10 (applying waiver to an available venue objection omitted from a prior motion to dismiss for improper venue). If a party can preserve any objection to venue by simply raising a venue *defense*—regardless of the *objection* underlying that defense—then the word "objection" in Rule 12(g)(2) would be superfluous. "[C]ourts 'must give effect, if possible, to every clause and word of a statute.'" *See Loughrin v. United States*, 134 S. Ct. 2384, 2390 (2014) (citation omitted). BlueTide's venue objection is therefore waived.

Hughes and BlueTide move to transfer § 1406, which applies only to cases "laying venue in the wrong division or district." Hughes and BlueTide waived their objections to venue. *See* § 1406(b) ("Nothing in this chapter shall impair the jurisdiction of a district court of any matter involving a party who does not interpose timely and sufficient objection to venue."); *In re Vitamins Antitrust Litig.*, 263 F. Supp. 2d 67, 68 n.1 (D.D.C. 2003) ("The Court need not address Defendants' motion pursuant to 28 U.S.C. § 1406(a). It is undisputed that Defendants have failed to timely object to venue or personal jurisdiction. The Federal Rules clearly provide that such objections are waivable defenses unless raised in a responsive pleading or by motion under Rule 12."); *see also Broad. Co. of the Carolinas v. Flair Broad. Corp.*, 892 F.2d 372, 377 (4th Cir. 1989). The motion to transfer is therefore **DENIED**, and the motion to stay pending Defendants' motion to transfer under § 1406 is **DENIED AS MOOT**.

3. Defendants' Pending Motion to Transfer under § 1404 (Dkt. 130)

Shortly before Defendants filed their motion to transfer under § 1406, Defendants alerted the Court to a document Defendants filed via ECF on May 24, 2016 simply as a "Sealed Document." *See* Dkt. 130. Although the document was titled "motion," the Court was not aware of it because the ECF system did not identify the document as a pending motion because Defendants' counsel did not file it as such. The Court is now aware of the motion and will resolve it in due time, but under the circumstances, a stay pending resolution of the motion to transfer under § 1404 is not warranted. Defendants had numerous occasions to alert the Court to the motion, and no such notice was given until more than a year after the motion was filed. Accordingly, Defendants' motion to stay pending transfer under § 1404 is **DENIED**. An Order on the pending motion to transfer under § 1404 will be forthcoming.

CONCLUSION

For the foregoing reasons, **IT IS ORDERED** that the parties’ pending motions are resolved as follows:

Motion	Dkt.	Disposition
Elbit’s Motion to Strike Invalidity Opinions	275	GRANTED-IN-PART and DENIED-IN-PART
Hughes’ Motion to Strike Infringement Contentions	276	DENIED
Hughes’ Priority Date Motion	277	GRANTED
Elbit’s Infringement Expert Motion (Dkt. 312)	312	DENIED
Hughes’ Motion to Exclude Patent Office Expert Testimony	313	GRANTED
Defendants’ Motion to Exclude Damages Expert Testimony	314	DENIED
Plaintiffs’ Motion to Strike Non-Infringing Alternatives	315	GRANTED
Hughes’ Motion to Strike Infringement Opinions	316	DENIED
Elbit’s Motion to Exclude Damages Expert Testimony	319	DENIED
Defendants’ Motion to Transfer	372	DENIED
Defendants’ Motion to Stay	373	DENIED AS MOOT

Additionally, the Court **RECOMMENDS** the following motions for summary judgment be resolved as follows:

Motion	Dkt.	RECOMMENDATION
Defendants’ “Switching Means” Motion	291	Deny

Defendants' "Means for Generating Request" Motion	292	Deny
Defendants' GMR-1 Products Motion	293	Deny
Defendants' Damages Motion	294	Deny
Hughes' Copying Motion	295	Deny
Hughes' Willfulness Motion	296	Deny
Hughes' Marking Motion	297	Deny
Motion for Summary Judgment of Noninfringement of the '874 Patent	298	Deny

A party's failure to file written objections to the findings, conclusions, and recommendations contained in this report within fourteen days after being served with a copy shall bar that party from de novo review by the district judge of those findings, conclusions, and recommendations and, except on grounds of plain error, from appellate review of unobjected-to factual findings and legal conclusions accepted and adopted by the district court. Fed. R. Civ. P. 72(b)(2); *see Douglass v. United Servs. Auto. Ass'n*, 79 F.3d 1415, 1430 (5th Cir. 1996) (en banc).

SIGNED this 20th day of June, 2017.

 ROY S. PAYNE
 UNITED STATES MAGISTRATE JUDGE