

UNITED STATES PATENT AND TRADEMARK OFFICE

---

BEFORE THE PATENT TRIAL AND APPEAL BOARD

---

SHENZHEN LIOWN ELECTRONICS CO., LTD.,  
Petitioner,

v.

DISNEY ENTERPRISES, INC.,  
Patent Owner.

---

Case IPR2015-01658<sup>1</sup>  
Patent 8,696,166 B2

---

Before TRENTON A. WARD, J. JOHN LEE, and WILLIAM M. FINK,  
*Administrative Patent Judges.*

FINK, *Administrative Patent Judge.*

FINAL WRITTEN DECISION  
*35 U.S.C. § 318(a) and 37 C.F.R. § 42.73*

---

<sup>1</sup> IPR2015-01352 was consolidated with this proceeding and administratively terminated. *See* Paper 9.

## I. INTRODUCTION

On July 31, 2015, Shenzhen Liown Electronics Co., Ltd. (“Petitioner”) filed a Petition requesting an *inter partes* review of claims 1–4, 7, 13, 14, 18–20, 22, and 26 of U.S. Patent No. 8,696,166 B2 (Ex. 1001, “the ’166 patent”). Paper 2 (“Pet.”). On November 11, 2015, exclusive licensee and real party-in-interest, Luminara Worldwide, LLC, acting under authority of Disney Enterprises, Inc. (collectively, “Patent Owner”), filed a Preliminary Response. Paper 6 (“Prelim. Resp.”); Paper 5, App’x. 1 (agreement). On February 9, 2016, we instituted trial as to claims 1–4, 7, 13, 14, 18–20, 22, and 26 of the ’166 patent on the grounds of unpatentability, under 35 U.S.C. § 103(a), that were alleged in the Petition. Paper 7 (“Inst. Dec.”).

After institution, Patent Owner filed a Patent Owner Response (“PO Resp.”). Paper 20. Petitioner filed a Reply to the Patent Owner Response. Paper 29 (“Pet. Reply”). A consolidated oral hearing for IPR2015-01656, IPR2015-01657, and IPR2015-01658 was held on October 18, 2016. A transcript of the hearing has been entered into the record. Paper 47 (“Tr.”).

This Final Written Decision (“Decision”) is issued pursuant to 35 U.S.C. § 318(a). For the reasons explained below, we conclude Petitioner has demonstrated, by a preponderance of the evidence, that claims 1–4, 7, 13, 14, 18–20, 22, and 26 of the ’166 patent are unpatentable.

### *A. Related Matters*

Petitioner and Patent Owner identify the following pending judicial matters as relating to the ’166 patent: *Luminara Worldwide, LLC v. Liown Electronics Co., Ltd.*, Case No. 14-cv-03103 (D. Minn.), filed August 5, 2014; *Luminara Worldwide, LLC v. Liown Electronics Co., Ltd.*, Case No.

15-1671 (Fed. Cir.), filed May 21, 2015; *RAZ Imports, Inc. v. Luminara Worldwide, LLC*, Case No. 3-15-cv-02223 (N.D. Tex.), filed July 3, 2015; and *Luminara Worldwide, LLC v. RAZ Imports, Inc.*, Case No. 15-cv-03028 (D. Minn.), filed July 10, 2015. Pet. 1–2; Paper 5, 1–2.

In addition to this proceeding, the following *inter partes* reviews are pending in which related patents are challenged:

IPR	Patent	Stage
2015-01656	U.S. Patent No. 8,070,319	Trial
2015-01657	U.S. Patent No. 8,534,869	Trial
2016-01785	U.S. Patent No. 8,721,118	Pre-Institution
2016-01834 2016-01835	U.S. Patent No. 8,727,569	Pre-Institution

*B. The '166 Patent*

The '166 patent relates to “simulating a flickering flame providing kinetic light movement,” such as the simulation of a single candle flame. Ex. 1001, 1:24–30. Figure 1 of the '166 patent is reproduced below:

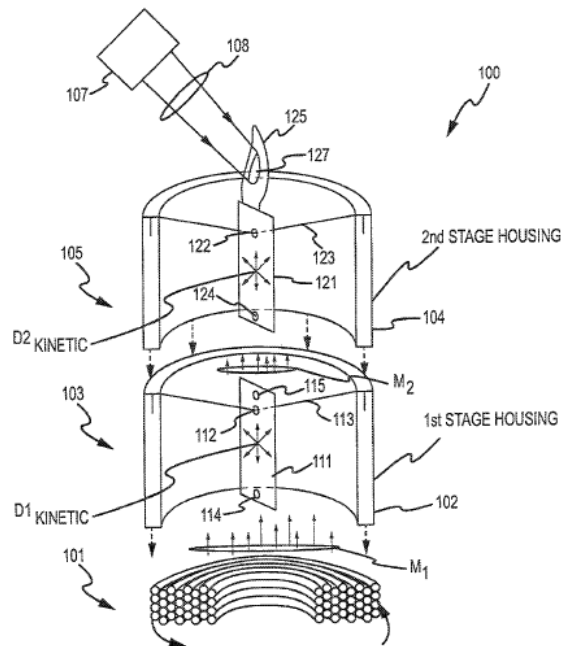

FIG. 1

Figure 1 illustrates an embodiment of the kinetic flame device, in accordance with the claimed invention, resembling a conventional wax candle. Ex. 1001, 3:65–67, 5:20–22. As shown in Figure 1, single coil 101 may be distributed about the central axis of the device to act upon upper and lower pendulum members 111 and 121. *Id.* at 5:56–67. Specifically, energized coil 101 produces a time-varying magnetic field, which acts upon magnet 114 on lower or first-stage pendulum 111 to produce kinetic motion  $D1_{\text{Kinetic}}$ . *Id.* at 6:1–3, 6:22–27. First-stage pendulum 111 is “pivotally supported” by support 113, which may be a rod, axle, wire, or the like, and which passes through hole 112 to allow the kinetic motion about the pivot point. *Id.* at 7:14–27. The second stage 105 is similar in construction and operation to the first stage, with second-stage pendulum 121 pivotally mounted on support element 123. *Id.* at 9:7–13. Flame silhouette 125 extends from the top of second-stage pendulum 121 and is formed into a flame-shaped outline. *Id.* at 9:34–38. Flame silhouette 125 moves with kinetic movement  $D2_{\text{Kinetic}}$  of second-stage pendulum 121 and is illuminated by spotlight 107. *Id.* at 10:39–48. Although Figure 1 represents a two-stage embodiment, single-stage only embodiments are also described, such as depicted in Figure 7. *Id.* at 15:26–35, Fig. 7.

### *C. Illustrative Claim*

Claims 1, 13, and 26 are independent claims. Claims 2–4 and 7 directly or indirectly depend from claim 1; and claims 14, 18–20, and 22 directly or indirectly depend from claim 13. Claim 1 is reproduced below.

1. A pendulum member for generating a flickering flame effect, comprising:
  - a body with upper and lower portions;

a flame silhouette element extending outward from the upper portion of the body; and

a hole in the body below the flame silhouette element, wherein the hole is configured to receive a flame support element such that the flame support element passes through the hole and the body is free to pivot when supported by the flame support element.

Ex. 1001, 23:42–51.

#### *D. Pending Grounds of Unpatentability*

The first pending ground of unpatentability challenges independent claims 1 and 13 as anticipated, under 35 U.S.C. § 102(b), by Schnuckle '455.<sup>2</sup> The second pending ground of unpatentability challenges claims 2–4, 14, 20, and 22 as obvious, under 35 U.S.C. § 103(a), over the teachings of Schnuckle '455. The third ground of unpatentability challenges dependent claims 18 and 19 and independent claim 26 as obvious, under 35 U.S.C. § 103(a), over the teachings of Schnuckle '455 and Helmer.<sup>3</sup> The fourth ground of unpatentability challenges dependent claim 7 as obvious, under 35 U.S.C. § 103(a), over the teachings of Schnuckle '455 and Cornell.<sup>4</sup> The fifth ground of unpatentability challenges independent claims 1 and 13 and dependent claims 2–4, 14, 18, 20, and 22 as obvious, under 35 U.S.C. § 103(a), over the teachings of Wiklund<sup>5</sup> and Baba.<sup>6</sup> The sixth

---

<sup>2</sup> U.S. Patent No. 7,261,455 B2, issued Aug. 28, 2007 (Ex. 1003) (“Schnuckle '455”).

<sup>3</sup> U.S. Patent No. 817,772, issued Apr. 17, 1906 (Ex. 1005) (“Helmer”).

<sup>4</sup> U.S. Patent No. 2,984,032, issued May 16, 1961 (Ex. 1004) (“Cornell”).

<sup>5</sup> WO 85/03561, published Aug. 15, 1985 (Ex. 1006) (“Wiklund”).

<sup>6</sup> Japanese Unexamined Patent Application No. 2000-284730, published Oct. 13, 2000 (Ex. 1007) and certified English translation of Ex. 1007 (Ex. 1008) (“Baba”).

ground of unpatentability challenges dependent claim 19 and independent claim 26 as obvious, under 35 U.S.C. § 103(a), over the teachings of Wiklund, Baba, and Meeker.<sup>7</sup> The seventh pending ground of unpatentability challenges independent claims 1–3 as anticipated, under 35 U.S.C. § 102(b), by Sandell.<sup>8</sup> The eighth ground of unpatentability challenges dependent claim 7 as obvious, under 35 U.S.C. § 103(a), over the teachings of Sandell and Hall.<sup>9</sup>

## II. DISCUSSION

### *A. Level of Ordinary Skill in the Art*

Petitioner’s declarant, Dr. Delson, testifies:

a person of ordinary skill in the art at the time of the alleged invention would have had a Bachelor’s degree in mechanical engineering and one to three years of mechanical design experience. This description is approximate and additional educational experience in mechanical engineering could make up for less work experience and vice versa.

Ex. 1002 ¶ 34. Patent Owner’s declarant, Dr. Brown, testifies that “a person [of ordinary skill in the art] typically would have a mechanical engineering degree (either a bachelor’s degree or associate’s degree), and would have some familiarity, training, or experience with electric lighting devices.”

Ex. 2010 § 14.

We find these “definitions” to be substantially similar. For example, both require at least a mechanical engineering degree and experience varying between “some,” in Dr. Brown’s opinion, and “one to three years,” in Dr. Delson’s opinion. Given this apparent lack of disagreement, we adopt

---

<sup>7</sup> U.S. Patent No. 782,156, issued Feb. 7, 1905 (Ex. 1009) (“Meeker”).

<sup>8</sup> U.S. Patent No. 4,551,794, issued Nov. 5, 1985 (Ex. 1010) (“Sandell”).

<sup>9</sup> U.S. Patent No. 1,842,167, issued Jan. 19, 1932 (Ex. 1011) (“Hall”).

Dr. Delson’s statement of the level of ordinary skill for purposes of this Decision, but we note that our analysis would be the same under either formulation.

*B. Claim Interpretation*

In an *inter partes* review, claim terms in an unexpired patent are given their “broadest reasonable construction in light of the specification of the patent in which it appears.” 37 C.F.R. § 42.100(b); *Cuozzo Speed Techs., LLC v. Lee*, 136 S. Ct. 2131, 2142–46 (2016). Under the broadest reasonable construction standard, claim terms are generally given their ordinary and customary meaning, as would be understood by one of ordinary skill in the art in the context of the entire disclosure. *In re Translogic Tech., Inc.*, 504 F.3d 1249, 1257 (Fed. Cir. 2007).

1. “flame silhouette element”

In the Decision to Institute, we construed the term “flame silhouette element,” recited in at least claims 1 and 26, as “a body of material having a shape that is suitable to generate a flame flickering effect.” Inst. Dec. 9. In their respective Response and Reply, neither party disputes the preliminary construction of this term. Accordingly, we see no reason to change our construction, which we based on the broadest reasonable interpretation, consistent with the Specification.

2. “free to pivot” and “swings or pivots freely”

In its Preliminary Response for IPR2015-01352<sup>10</sup> (Ex. 3001), Patent Owner argued that “free to pivot” in claim 1 and “swings or pivots freely” in

---

<sup>10</sup> IPR2015-01352 was consolidated with this proceeding. Paper 9. The Preliminary Response in this proceeding (IPR2015-01658) did not address Petitioner’s arguments on the merits.

dependent claim 14 means that “the body is able to move in an unconstrained manner about a single support in multiple axial directions.” Ex. 3001, 13. In the Decision to Institute, we rejected this construction, but, in considering the Specification, we determined that the term “free to pivot” and “swings or pivots freely” should be construed as “pivoting with little or no impediment or resistance.” Inst. Dec. 11–13 (citing Ex. 1001, 8:7–11).

Although the parties do not argue that this preliminary construction should be changed (*see, e.g.*, PO Resp. 10–15), they raise arguments regarding its interpretation, which require us to clarify the construction. Specifically, Patent Owner contends that “under the Board’s construction, Baba’s swing beam 4 is not free to swing or pivot because its motion is resisted by the braking force of the magnet 10.” PO Resp. 38. Petitioner responds that Patent Owner mischaracterizes the term “resistance” in the preliminary construction “little or no resistance,” which it contends meant resistance by the pivot mechanism rather than external forces. Pet. Reply 20–21. We agree with Petitioner.

As pointed out by Petitioner, similar to Baba, the ’166 patent specification describes magnets attached to the pendulum member to “more effectively *dampen, heighten, or otherwise modify the magnitude* of the kinetic movement . . . or its chaotic nature.” Ex. 1001, 19:9–30 (emphasis added); *id.* at 18:55–64 (“[T]he kinetic movement . . . may be dampened . . . in response only to magnetic field  $M_2$ .”). Thus, in the ’166 patent, dampening the pendulum movement using magnets is an element of the kinetic movement (or its chaotic nature) of the pendulum, regardless of the pivot action—free or not.



On the other hand, as we observed in the Decision to Institute, the '166 patent specification uses the term “pivots freely” only once, and only to describe the situation in which “hole 112 in pendulum member 111 is sufficiently larger than the diameter of support wire 113 such that pendulum 111 swings or pivots freely.” Inst. Dec. 11 (quoting Ex. 1001, 8:7–11). This description of a larger hole than the support wire as causing the pendulum to pivot freely, suggests that its the pivot *mechanism* that does not resist pivoting or swinging. This is consistent with the specification’s description of magnets or magnetic forces dampening the movement of the pendulum to create chaotic movements, as these forces are not related to the pivot mechanism. Accordingly, we clarify our previous preliminary construction of “free to pivot” or “pivots freely” to mean “pivoting with little or no resistance *by the pivot mechanism.*” See Inst. Dec. 11–13 (modification shown in italics).

3. “pivot” and “pivotally supported”

a. Federal Circuit’s Construction of “pivot”

After the Decision to Institute, the Federal Circuit reviewed the '166 patent to determine whether, in a related district court action, Luminara (i.e., Petitioner) had raised a substantial question of validity sufficient to avoid a preliminary injunction. See *Luminara Worldwide, LLC v. Liown Elecs. Co.*, 814 F.3d 1343 (Fed. Cir. 2016); see also PO Resp. 9–13 (discussing the Federal Circuit’s *Luminara* decision); Pet. Reply. 2–5 (same). Significantly, the Federal Circuit held that the '166 patent’s specification “disclaims non-chaotic pivoting” and “devices driven by rhythmic or metronomic patterns,” with “no further requirements on movement.” *Luminara*, 814 F.3d at 1353–54 (internal quotations omitted).

The Federal Circuit further held that Schnuckle '455 indisputably teaches pivoting in two axes and “seems” to disclose chaotic movement. *Id.* at 1354. As a result, the Federal Circuit determined that Petitioner’s anticipation argument based on Schnuckle '455 raised a substantial question of validity and reversed the district court’s grant of a preliminary injunction against Petitioner. *Id.*

Although the Federal Circuit’s opinion appears to fully address the scope of the disclaimer sufficiently enough for the Federal Circuit to preliminarily determine that Schnuckle '455 discloses the disputed pivotally mounted limitation, Patent Owner raises additional arguments here concerning what the Federal Circuit meant with its “chaotic pivoting” requirement.

b. Patent Owner’s Position

Relying on various extrinsic evidence, Patent Owner contends “chaotic” means aperiodic, unpredictable behavior arising in a system extremely sensitive to initial conditions. PO Resp. 11 (citing Ex. 2013, 234; Ex. 2014, 0009; Ex. 2010 ¶ 16); Tr. 51:17–22. Based on this meaning of chaotic, Patent Owner further contends:

Importantly, the flame element moves chaotically *not* because of the nature of driving force that initially perturbs the pendulum. Indeed, all the driving force has to do is “kick” the pendulum into motion. Rather, it is *the pivotal mounting*, not the kick, that ensures that the motion of the flame element is chaotic. The Federal Circuit did not consider this particular point when it concluded that a substantial question of validity existed with respect to Schnuckle ['455].

PO Resp. 12 (internal citations omitted). In other words, according to Patent Owner, it is the pivotal mounting structure, not the driving force, that makes the pivoting *chaotic* within the meaning of that term. *Id.*

Thus, Patent Owner essentially views *Luminara* as requiring two disclaimers of different scope, one of devices driven by rhythmic or metronomic patterns, and one of non-chaotic pivoting devices. Tr. 54:5–13. The latter imposes additional constraints on the pivotal mounting structure, including extreme sensitivity to initial conditions. Tr. 50:1–6. Relying on Dr. Brown’s testimony, Patent Owner contends this definition of chaotic pivoting requires three, independent, non-linear types of motions that must not be controlled or modulated. PO Resp. 12 (citing Ex. 2010 ¶¶ 17–21).

Patent Owner also argues that the claims are entitled to an interpretation that preserves their validity over Schnuckle ’455. PO Resp. 12–14. Specifically, Patent Owner contends that because Schnuckle ’455 was before the Examiner during prosecution of the ’869 patent (*id.* at 13 (“Schnuckle appears on the face of the ’869 patent”)), it is reasonable to infer that the Examiner considered Schnuckle ’455 and “appreciated the differences” (*id.*) between it and the challenged claims. According to Patent Owner, any ambiguity (i.e. whether Schnuckle ’455’s two-axis mounting structures should read on the claimed pivotal mounting structure) should be resolved with an eye towards preserving the validity of the claims over the prior art of record and exclude Schnuckle ’455’s two-axis mounting. *Id.* at 13–14 (citing *Phillips v. AWH Corp.*, 415 F.3d 1303, 1327 (Fed. Cir. 2005) (en banc)).

c. Analysis

As noted above, based on a mathematical definition of *chaotic*, Patent Owner views *Luminara* as requiring two disclaimers of different scope, one of the driving mechanism (i.e., excluding rhythmic or metronomic) and one of the pivotal mounting (i.e., excluding non-chaotic). We have reviewed the evidence, and we conclude that neither the Federal Circuit’s *Luminara* opinion nor the ’166 patent support this position.

We start with the relevant portion of the Federal Circuit’s opinion, which also reproduces relevant portions of the specification of the ’166 patent:

By contrast, the specification disclaims non-chaotic pivoting. It explains that solitary flames are “complex kinetic interactions” that “produce a continuously and randomly moving light.” ’166 patent, col. 1 ll. 39–41. It teaches that flame displays in the prior art “are relatively poor imitations of a real flame and have not been widely adopted by the commercial or retail markets.” *Id.* at col. 2 ll. 13–16. The specification further explains that “[t]he present description addresses the above and other problems by providing kinetic flame devices that create lighting effects driven by *real but chaotic physical movements*.” *Id.* at col. 2 ll. 23–25 (emphasis added); *see also id.* at col. 4 ll. 52–58 (“The present description involves devices that create lighting effects driven by real, chaotic, and physical movements.”), col. 4 l. 62–col. 5 l. 2 (“[T]he present invention stimulates and/or perturbs a complex interaction between gravity, mass, electromagnetic field strength, magnetic fields, air resistance, and light, but the complex interaction is not directly modulated or controlled.”). . . .

*Luminara*, 814 F.3d at 1353–54. As the above excerpt indicates, the Federal Circuit bases the disclaimer of “non-chaotic pivoting” on the ’166 patent specification’s description of the nature of solitary flames (i.e.,

“continuously and randomly moving”), the deficiencies of the prior art (i.e., “poor imitations”), and the present invention’s requirement for “lighting effects driven by *real but chaotic physical*” movements.

In other words, the Federal Circuit viewed the specification’s description of the driving forces (i.e., “real but chaotic” and “not directly modulated or controlled”) as significant in finding the disclaimer of non-chaotic pivoting, as summarized in the concluding sentence of the above paragraph:

By teaching that the “present description” solves the problems associated with the prior art candle devices because it is driven by “real but chaotic movements,” the patentee disclaims devices driven by rhythmic or metronomic patterns.

*Id.* at 1354. Thus, the Federal Circuit started the paragraph by stating that the specification disclaimed non-chaotic pivoting, and then, after reviewing the ’166 patent specification evidence, concluded that this meant the patentee disclaims devices driven by rhythmic or metronomic patterns. We discern no suggestion by the Federal Circuit that it believed the disclaimer of chaotic pivoting to require more than not being driven by rhythmic or metronomic patterns such that Patent Owner’s mathematical definition of chaos is required.

Although we disagree with Patent Owner’s reading of the Federal Circuit’s opinion, we have also considered its mathematical definition of chaotic, i.e., requiring sensitivity to initial conditions, in light of the ’869 patent specification.<sup>11</sup> As an initial matter, the ’166 patent specification

---

<sup>11</sup> We note that Patent Owner’s construction of “chaos” is based on a dictionary definition (Ex. 2013) we cited in our Decision to Institute in related IPR2015-01656, Ex. 3001. PO Resp. 11; IPR2015-01656, Inst. Dec.

does not support or suggest a sensitivity to initial conditions. Tr. 61:11–12 (Patent Owner: “The Petitioner is right, the specification doesn’t talk about that.”).

Moreover, as Petitioner points out, the specification uses “chaotic” nearly “interchangeably with both ‘unpredictable’ and ‘random.’” Pet. Reply 5–6 (citing, e.g., Ex. 1001, 19:15–20 (explaining that magnets may modify the kinetic movement or “its chaotic nature (e.g., make the movement,  $D2_{Kinetic}$ , more unpredictable.)”)); *see* Ex. 1001, 3:16–24, 6:22–27, 7:2–7, 8:49–52, 9:51–53. Patent Owner’s declarant apparently agrees that “random” is not chaotic in the mathematical sense. *See* Ex. 1024, 96:13–22 (“random is not chaotic and chaotic is not random”). These frequent references to “chaos” or “chaotic” used synonymously with terms that do not require chaos in the mathematical sense in the ’869 patent specification suggest that a looser, colloquial meaning for “chaos” or “chaotic” was adopted by applicant.

Furthermore, as Petitioner points out (Pet. Reply 6), Patent Owner’s declarant stated that a system is either chaotic in the mathematical sense or it is not. Ex. 1024, 31:20–23 (“Chaos is an existence or nonexistence phenomenon, and there are different types of chaotic motion, but I’m not aware of any sliding scale which measures the amount of chaos”). The

---

14 n.12 (citing Ex. 3001, 234). However, there, we cited this definition as evidence that the “kinetic motion” and “chaotic motion” terms in the ’319 patent, generally do not mean the same thing in response to Patent Owner’s preliminary joint proposed construction of both terms. *Id.* at 14. It bears emphasis that we rejected an interpretation of “kinetic motion” in claim 3 and “chaotic motion” in claim 17 as requiring movement in three orthogonal axes, as we similarly reject that requirement for the “pivot” term here. *Id.* at 12–13.

specification, however, uses the term chaos in conjunction with relative terms such as “more” (Ex. 1001, 3:39–44, 7:22–27), “increasingly” (*id.* at 7:42–45), or “enhance” (*id.* at 11:63–67). When combined with the way the specification interchangeably uses chaotic, unpredictable, and random, these terms of degree further suggest that a person of ordinary skill in the art would have understood the specification to use the term chaos in a colloquial sense to indicate the extent to which the flame element moves naturally or realistically. Indeed, Petitioner provides evidence that a person of ordinary skill in the art, as defined by Patent Owner (i.e., having a bachelor’s or associate’s degree), would not have been educated on mathematical chaos theory. Pet. Reply 8–9 (citing Ex. 1024, 37:2–17). This view is consistent with the patent’s stated objective, i.e., “provid[ing] a convincing simulation that appears real or natural to a viewer.” Ex. 1001, 1:43–47.

Notwithstanding our disagreement with Patent Owner’s mathematics-based interpretation of the disclaimer addressed by the Federal Circuit, we also consider whether Patent Owner’s construction of “pivotally mounted” (i.e., requiring three, independent, non-linear types of motions that must not be controlled or modulated) is appropriate. *See* PO Resp. 11. We conclude it is not. Though preliminary, the Federal Circuit specifically rejected this reading both before and after determining that non-chaotic pivoting is disclaimed. *Luminara*, 814 F.3d at 1352–53 (rejecting the district court’s construction that “free to pivot” requires “movement that is more than rotation around two axes”; “Pivoting includes rotation around a single axis.”), 1354 (finding that “[t]he [Schnuckle] ’455 patent undisputedly teaches pivoting in two axes” and the “final limitation in claim 1 of the ’166

patent—chaotic movement—seems to be met . . . in the prior art [Schnuckle] '455 patent.”).

We agree with the Federal Circuit’s analysis, because it is consistent with the intrinsic evidence. Conversely, Patent Owner’s proposed construction contradicts the intrinsic evidence in other respects. For example, claim 17 of the related ’319 patent<sup>12</sup> has a limitation directed to both pivoting (i.e. “allowing the pendulum to pivot about the hole on the support wire”) and “chaotic motion at the coupling member *in at least two dimensions.*” IPR2015-01656, Ex. 1001, 23:28–30 (emphasis added). By requiring chaotic motion in at least two dimensions (as on a single-axis allowing rotation in one plane), the claims suggest chaotic motion nominally includes motion in even one dimension, as in up or down or side to side. On the other hand, interpreting the specification disclaimer of “chaotic pivoting” for purposes of claim 1 of the ’319 patent to require three, independent non-linear types of motion, as Patent Owner argues, would lead to the incompatible result that claim 17 of the ’319 patent, which requires movement in only two dimensions, would cover devices that are disclaimed by the specification.

Finally, we have also considered Patent Owner’s argument that any ambiguity in the claim language should be resolved in a manner that would preserve the patent’s validity, especially where, as here, the prior art was expressly considered during examination. PO Resp. 12–14. We find this argument unavailing as well. First, Patent Owner relies on *Phillips* for this

---

<sup>12</sup> As set forth in the final decision in IPR2015-01656, we agree with both parties that the disclaimer of non-chaotic pivoting also applies to the ’319 patent as well as the ’166 patent in this proceeding.



proposition. *Id.* (citing 415 F.3d at 1327). However, as Patent Owner acknowledges (PO Resp. 10), we apply the broadest reasonable interpretation consistent with the specification, not the *Phillips* standard. *See Cuozzo*, 136 S. Ct. at 2134, 2144–46. Patent Owner has not directed us to any case in which a claim term’s *broadest reasonable interpretation* turned on preserving its validity. Regardless, even under *Phillips*, this canon of construction only applies in situations where the proposed claim interpretation is “practicable” and “based on sound claim construction principles,” even where the prior art at issue is part of the prosecution history. *Generation II Orthotics, Inc. v. Medical Techs., Inc.*, 263 F.3d 1356, 1365 (Fed. Cir. 2001). As we determined above, Patent Owner’s proposed construction of the disclaimer is unsupported by, and even contrary to, the specification of the ’166 patent.

We determine that the Federal Circuit’s statement of the disclaimer of “non-chaotic pivoting” and devices “driven by rhythmic and metronomic patterns,” *Luminara*, 814 F.3d at 1353–54, is sufficiently specific to determine the scope of the term “pivot” in claim 1 and “pivotally supported” in claim 13.<sup>13</sup> Accordingly, we apply the Federal Circuit’s construction that the plain and ordinary meaning of “pivot” and “pivotally supported” applies,

---

<sup>13</sup> We have also considered Patent Owner’s Motion for Observations (Paper 37), which are substantially directed at obtaining admissions from Petitioner’s declarant in support of its proposed construction of chaotic pivoting (or that Schnuckle ’455 does not disclose chaotic pivoting based on this construction). *See id.* at 6–13. Although we have considered Patent Owner’s observations, we do not find them persuasive for the reasons explained herein.

except that non-chaotic pivoting and devices driven by rhythmic and metronomic patterns are disclaimed.

*C. Anticipation of Claims 1 and 13 by Schnuckle '455*

Petitioner argues that claims 1 and 13 of the '166 patent are unpatentable, under 35 U.S.C. § 102(b), as anticipated by Schnuckle '455. *See* Pet. 16–22. We have reviewed the Petition, Patent Owner's Response, Petitioner's Reply, as well as the relevant evidence discussed in those papers and other record papers. As described in further detail below, we determine that the record supports Petitioner's contentions for claims 1 and 13, challenged as anticipated by Schnuckle '455, and we adopt Petitioner's analysis discussed below as our own. For reasons that follow, we determine that Petitioner has shown by a preponderance of the evidence that claims 1 and 13 of the '166 patent are anticipated Schnuckle '455.

*1. Schnuckle '455 (Ex. 1003)*

Schnuckle '455, which shares a common inventor with the '166 patent (Prelim. Resp. 1), describes an imitation candle comprising a simulated candle housing and a simulated flame mounted on a pendulum within the housing. Ex. 1003, Abstract, Figs. 2, 7, 12.

Figures 7 and 12 of Schnuckle '455 are reproduced below:

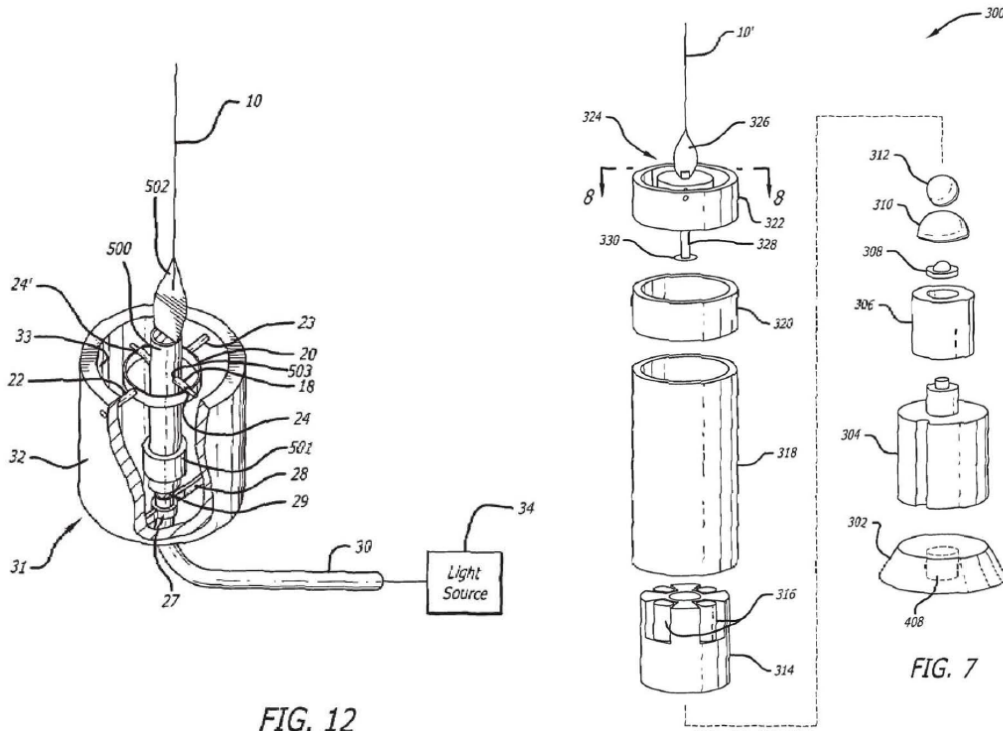

FIG. 12

FIG. 7

Figures 7 and 12 above illustrate an artificial candle in accordance with the invention of Schnuckle '455. Ex. 1003, 2:49–50, 2:56–57. As shown in Figure 12, teardrop shaped element 502 resembling a flame is secured to the upper end of channel 500. *Id.* at 6:47–49. Rod 18 passes through hole 503 in channel 500. *Id.* at 6:49–50. Rod 18 is disposed in grooves 24 and 24' of ring shaped member 20 of the gimbal mechanism. *Id.* at 3:55–65, 6:49–52, Figs. 2, 12. Ring shaped member 20 is connected to housing 32 by a pair of pins, 22 and 23, “each pin 22, 23 being fixedly secured to the outer periphery of member 20 and rotatably secured to the inner wall of housing 32.” *Id.* at 3:56–60. “The pins 22 and 23 thus permit the member 20 of the gimbal mechanism to rotate about the longitudinal axes of pins 22 and 23.” *Id.* at 3:60–62.

Air from a fan is blown or injected against the components from the bottom of the candle housing to cause the components to move on the

gimbal mechanism. *Id.* at 3:41–45. The Figure 7 embodiment is similar but for the use of electromagnets 316 instead of air to drive the lower end of the pendulum to simulate the movement of the flame blowing in the wind. *Id.* at 5:13–32, 6:53–62.

2. Claims 1 and 13

Claim 1 recites a “pendulum member for generating a flickering flame effect.” Petitioner contends Schnuckle discloses channel 500 in Figure 12 with teardrop flame element 502 for generating a flickering flame effect. Pet. 18 (citing Ex. 1003, Abstract, 1:54–58, 6:42–52). Claim 1 also recites “a body with upper and lower portions.” According to Petitioner, channel 500 includes an “upper portion” and a “lower portion.” Pet. 18–19. Claim 1 further recites “a flame silhouette element extending outward from the upper portion of the body.” Petitioner contends teardrop shaped flame element 502 extends from the upper portion (i.e., above where rod 18 passes through hole 503 in Figure 12) of channel 500 and is, therefore, such a flame silhouette element. Pet. 19 (citing Ex. 1003, 4:5–13, 6:47–49, Fig. 12). Petitioner contends the same disclosures apply to similar limitations of claim 13. *See id.* at 20–22. In its Response, Patent Owner does not address these limitations or the foregoing contentions. We determine the record supports Petitioner’s analysis with respect to these undisputed limitations and, therefore, adopt them as our own.

The final limitation of claim 1 recites “a hole in the body below the flame silhouette element, wherein the hole is configured to receive a flame support element such that the flame support element passes through the hole and the body is free to pivot when supported by the flame support element.” Petitioner contends hole 503 in channel 500 of Schnuckle ’455 is the hole in

the body below the flame silhouette element, which is configured to receive rod 18, which passes through the hole, and on which the body is free to pivot. Pet. 20 (citing Ex. 1003, 4:1–3, 4:36–39, 5:1–2; 6:48–49, Fig. 12); Ex. 1002 ¶¶ 54–57. Claim 13 recites a similar limitation except the body is “pivotally supported” and the support element extends across the interior space and through the hole. Petitioner contends rod 18 pivotally supports channel 500 of Schnuckle ’455 and extends across the interior space. *Id.* at 20–21 (citing 4:1–3, 4:36–39, 5:1–2; 6:48–49, Fig. 12).

In its Response, Patent Owner disputes these contentions as to the “pivot” term (claim 1) or “pivotally supported” term (claim 13). PO Resp. 13–21 (citing Ex. 2010 ¶¶ 55–56). Because Patent Owner’s arguments depend on Patent Owner’s interpretation of “chaotic pivoting,” which we do not adopt, we are not persuaded.

Although we disagree with Patent Owner’s arguments, we nonetheless consider whether Schnuckle ’455 sufficiently discloses the pivot (or pivotally supported) limitation given the disclaimer of non-chaotic pivoting and devices driven by rhythmic and metronomic patterns. As noted above, the Federal Circuit specifically determined, at least as a preliminary matter, that Schnuckle ’455 seemed to meet this claim requirement with its discussion of a two-axis gimbal articulated by “chaotic forces” that can articulate the flame element to “randomly simulate blowing in the wind. ’455 patent, col. 6, ll. 53–62.” *Luminara*, 814 F.3d at 1354.

We agree with the Federal Circuit’s preliminary determination. Although Patent Owner observes that “‘chaotic’ describes the ‘external or internal force’—i.e., the force entering the system, not the resulting motion” (PO Resp. 20–21), Patent Owner does not address the fact that this driving

force is coupled to resulting motion “simulating blowing in the wind” (Ex. 1003, 6:62) and “provid[ing] a realistic flame effect” (*id.* at 1:54–58). As such, we agree that this excerpt of Schnuckle ’455 satisfies the chaotic pivoting requirement and is not driven by a “rhythmic or metronomic” driving force. Pet. Reply 4 n.1. Petitioner also cites the discussion of “programmable movement patterns” as additional evidence of this fact. *Id.* (citing Ex. 1003, 5:52–67 (“The desired movement pattern of the flame shaped surface 326 may be encoded and stored in the memory module 408 of the control board 302 in the form of digital data or control signals.”)). We agree that the column 5 description in Schnuckle ’455 of programmable movement patterns, when viewed against column 6’s description relied upon by the Federal Circuit (Ex. 1003, 6:53–62), suggests the programmed pattern is not rhythmic or metronomic but natural and chaotic.<sup>14</sup> Accordingly, we find that Schnuckle ’455 discloses chaotic pivoting as required by claims 1 and 13.

Accordingly, for the foregoing reasons, we determine Petitioner has satisfied its burden of proving anticipation based on Schnuckle ’455 against claims 1 and 13 by a preponderance of the evidence.

---

<sup>14</sup> We also do not agree with Patent Owner’s argument that a two-axis gimbal “modulates or controls movement” or restricts movement to “two controlled and predictable paths.” See PO Resp. 19–20. As Patent Owner’s declarant, Dr. Brown, testified, “[t]he gimbal with its two axes of motion constrains that motion be basically defining the surface of a sphere. *But what dictates the trajectory of that tip over time is the control module on the circuit board.*” Ex. 1024, 145:19–146:6 (emphasis added). As such, the gimbal does not restrict the flame element from moving chaotically.

*D. Obviousness of Claims 2–4, 14, 30, and  
22 by Schnuckle '455*

Petitioner argues that claims 2–4, 14, 20, and 22 of the '166 patent are unpatentable, under 35 U.S.C. § 103(a), as directed to obvious subject matter over Schnuckle '455. *See* Pet. 22–26. We have reviewed the Petition, Patent Owner's Response, Petitioner's Reply, as well as the relevant evidence discussed in those papers and other record papers. As described in further detail below, we determine that the record supports Petitioner's contentions for claims 2–4, 14, 20, and 22, as obvious over Schnuckle '455, and we adopt Petitioner's analysis discussed below as our own. For reasons that follow, we determine that Petitioner has shown by a preponderance of the evidence that claims 2–4, 14, 20, and 22 of the '166 patent would have been obvious over Schnuckle '455.

*3. Claims 2 and 3*

Claim 2 requires the pendulum member comprises “a magnetic or ferrous tag mounted on the lower portion of the body” and the hole be positioned “between the magnetic or ferrous tag and the flame silhouette element.” Petitioner contends that this feature is taught by Schnuckle '455 and that a person of ordinary skill in the art would add a magnetic base to the embodiment of Figure 12 to allow control using electronic circuitry. Pet. 22–23 (citing Ex. 1003, 5:13–6:11, 5:38–48, 6:1–7, Fig. 7). In particular, Petitioner contends a person of ordinary skill in the art would have added the magnetic base (as in Figure 7) to channel 500, as in Figure 12, to allow for the motion of channel 500 to be generated using magnets to provide more flexibility and control. *Id.*; Ex. 1002 ¶¶ 58–61.

Claim 3 requires the hole be “located in the body . . . such that the pendulum member hangs in a stable position due to gravity absent effects of

an electromagnetic field.” Petitioner contends the hole is positioned in Figure 12 so that it operates similarly to Figure 3, which is described as “a stationary state situation,” in which the pendulum hangs vertically due to gravity. Pet. 22–23 (citing Ex. 1003, 4:60–67). Petitioner contends that if this embodiment was combined with the magnetic base, the pendulum would hang vertically in the absence of an electromagnetic field. Pet. 23 (citing Ex. 1002 ¶¶ 62–63). In its Response, Patent Owner does not address claims 2 or 3 or the foregoing contentions. We determine the record supports Petitioner’s analysis with respect to these undisputed claims and, therefore, adopt them as our own.

4. Claims 4, 20, and 22

Claim 4 requires the pendulum body to be “elongated and planar.” Petitioner contends Schnuckle ’455 discloses elongated and planar pendulum bodies, “such as in Figs. 14 and 16–20 that show elongated pendulums made of . . . ‘flat material.’” Pet. 24 (citing 7:39–42). Petitioner further contends that a person of ordinary could have modified such pendulums (as in Figure 16) to include a hole to be pivotally supported on rod 18 as in Figure 12. *Id.*; Ex. 1002 ¶ 66. Petitioner relies on the lighting as arranged Figure 16, when using the planar pendulum of Figure 16. Pet. Reply 12. Figures 12 and 16 are reproduced below:



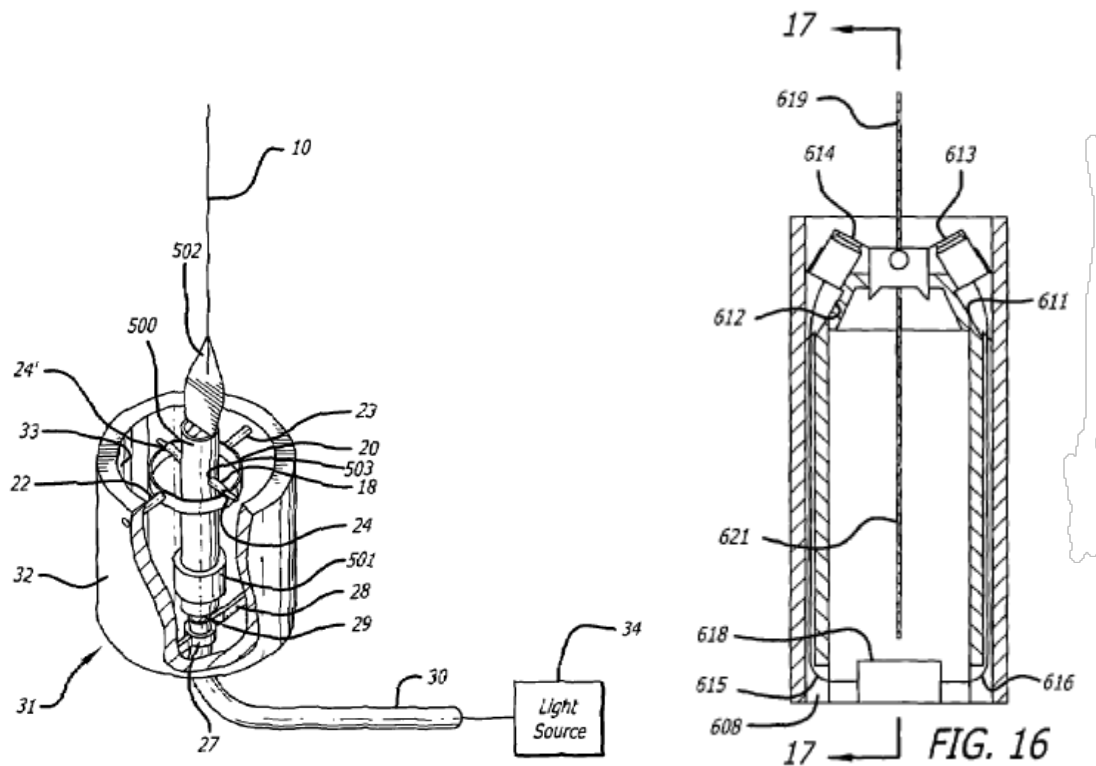

Figures 12 and 16 depict alternative embodiments of Schnuckle '455

According to Petitioner, “[s]uch an arrangement would have been advantageous because the planar pendulum can reduce the cost of manufacturing of the device by using a more compact and lighter pendulum element.” Pet. 24; Ex. 1002 ¶ 66.

In its Response, Patent Owner disputes Petitioner’s proposed rationale, arguing that, because the pendulum member of Figure 12 transmits light to the flame element, while the flat pendulum of other Schnuckle '455 embodiments do not, incorporating the flat pendulum would “destroy the utility of Schnuckle [’455].” PO Resp. 45–46 (citing Ex. 2011, 101:3–103:18). Although Patent Owner does not dispute that the lighting could

have been arranged as in the Figure 16 planar-pendulum embodiment,<sup>15</sup> Patent Owner argues that doing so would have added complexity, additional components and made the modification more costly, thus undermining Petitioner's cost rationale. *Id.* (citing Ex. 2010 ¶¶ 111–113). We disagree.

Patent Owner's argument, citing Dr. Delson's deposition testimony, that the planar pendulum of Figure 16 cannot transmit light, and, therefore, would not be suitable in combination with the embodiment of Figure 12 (*see* PO Resp. 45–46 (citing Ex. 2011, 101:3–103:18)), does not address the use of Figure 16's lighting arrangement at the top of the candle housing. We have considered this testimony, but fail to see anything that undermines Petitioner's reliance on Figure 16's lighting arrangement. *See* Ex. 2011, 101:3–103:18.

We have also considered Patent Owner's contention that this alternative arrangement would be more, not less, expensive (requiring additional components and added complexity) (*see* PO Resp. 47), but we are not persuaded. Although the arrangement of Figure 16 requires an extra light and wires, the lighting source of Figure 12 already requires standalone light source 34 (i.e., not integrated with the housing) and light conduit 30 to channel the light to the pendulum body, and hollow channel 500 to transmit the light. *Compare* Ex. 1003, Fig. 12 *with id.*, Fig. 16. Patent Owner states that the lighting must be arranged to sit above Figure 12's gimbal arrangement, but does not explain why this necessarily adds to cost. Thus,

---

<sup>15</sup> Patent Owner argues that “*the Board* [improperly] suggested the possibility of relocating the light source.” *Id.* at 46 n.4. We disagree. We simply recognized that Figure 16, which Petitioner relies on for the planar pendulum, explains how to arrange the lighting. Inst. Dec. 20.

we do not find that the arrangement of Figure 16's lighting above Figure 12's gimbal arrangement (*see* PO Resp. 46–47; Ex. 2010 ¶ 111) would create additional costs or pose unique design challenges that undermine Petitioner's asserted rationale. *KSR Int'l Co. v. Teleflex, Inc.*, 550 U.S. 398, 418 (2007) (“[A] court can take account of the inferences and creative steps that a person of ordinary skill in the art would employ.”); *Leapfrog Enters., Inc. v. Fisher-Price, Inc.*, 485 F.3d 1157, 1162 (Fed. Cir. 2007) (finding no evidence the proposed combination would have been “uniquely challenging or difficult for one of ordinary skill in the art”).

Accordingly, we determine the record supports Petitioner's analysis with respect to the rationale for combining Schuckle '455's embodiments to obtain a planar and elongated pendulum as set forth in claim 4. Claim 20 recites a similar limitation (as well as a limitation similar to claim 2). Claim 22 depends from claim 20 and recites a limitation similar to claim 3. Except as discussed above, the parties do not separately argue these claims, and we, therefore, adopt Petitioner's analysis with respect to claims 4, 20, and 22.

#### 5. Claim 14

Claim 14 requires the “pivot hole” (of claim 13) to be “larger in diameter than the exterior dimension of the support element, whereby the flame body swings or pivots freely about the support element.” Petitioner contends that in Schuckle '455's single-channel embodiment (Figure 12), channel 500 includes hole 503, through which rod 18 (i.e., the support element) passes, and on which channel 500 freely pivots. Pet. 25 (citing Ex. 1003, 6:47–49, 4:5–10, 4:36–39, 5:1–12, Fig. 4). Citing its declarant, Petitioner contends that a person of ordinary skill in the art would have

recognized that a larger hole would be require to allow for the requisite movement of the channel “about” rod 18. *Id.* (citing Ex. 1002 ¶ 74).

Patent Owner contends the references do not teach or suggest a larger pivot hole (than the diameter of the support element) such that the flame body may swing or pivot freely.<sup>16</sup> PO Resp. 31. More specifically, Patent Owner contends:

Neither Petitioners nor their expert Dr. Delson could specify where rotation is alleged to occur in Schnuckle. But a POSITA would have understood that channel 500 rotates *with* rod 18—not *about* rod 18. . . . Rotation occurs at the grooves. (Ex. 2010, Brown Decl. ¶ 81.) Because rotation occurs at the grooves, it cannot occur about hole 503. (*Id.*) Rotation about both locations would inevitably result in no displacement of the position of element 12 or 502 around the axis of rotation. (*Id.*) This is because rotation at one end of rod 18 would be cancelled by rotation at the center of rod 18. (*Id.*)

PO Resp. 33. We disagree.

As an initial matter, Petitioner cited several portions of Schnuckle '455 where channel 500 was said to move “about” rod 18. For example, Schnuckle '455 discloses “rotation of the flame shaped element 12 *about* rod 18” (Ex. 1003, 4:36–39 (emphasis added)), and describes “substantial rotational movement by an angle *about* rod 18” (*id.* at 5:1–2 (emphasis added)). *See also* Ex. 1002 ¶ 56. As Petitioner’s declarant, Dr. Delson, points out, the conventional usage of rotation about a structure

---

<sup>16</sup> To the extent Patent Owner is also arguing that claim 14 also requires that the flame body is “capable of even more independent, non-linear types of motion-beyond at least a tilt, a rotation, and a twist” (PO Resp. 31), as a result of the larger hole, we disagree. These requirements are not recited in the claim.

suggests movement relative to the structure. Ex. 1019 ¶ 33 (“The use of the terminology of rotational movement about a body, indicates relative motion between two parts.”). We find this testimony credible. Indeed, as pointed out by Petitioner (Pet. Reply 11), Patent Owner, too, follows this convention when describing the Baba reference (PO Resp. 36 (“A POSITA interpreting Baba would have understood that swing beam 4 rotates *with* shaft 3, not *about* shaft 3.”)).

As to Patent Owner’s argument that rod 18 is disclosed as rotating in the grooves and, therefore, “[rotation] cannot occur about hole 503” (PO Resp. 32), we are not persuaded. Rotation could occur both by rod 18 and by channel 500 *about* hole 503 relative to rod 18 at the same time. It does not necessarily follow that these rotate in opposite directions, such that there would be no movement of flame element 502, as the pendulum is driven at the lower end. *See* Ex. 1003, 4:17–23, Fig. 2. Thus, we credit Dr. Delson’s testimony (*see* Ex. 1002 ¶¶ 55, 74) that Schnuckle ’455 at least teaches or suggests rotational movement of the pendulum member relative to (i.e., “about”) rod 18.<sup>17</sup> We also agree that, because Schnuckle ’455 teaches such

---

<sup>17</sup> We do not consider Dr. Delson’s alternative theory that Figure 2 shows a large gap (i.e., hole) at the point where rod 18 passes through cables 14 and 16 (*see* Ex. 1019 ¶ 32). Moreover, Dr. Delson does not identify any indication that the drawing was intended to accurately represent a gap. We also do not consider Patent Owner’s argument at the oral hearing that, if hole 502 was larger than the diameter of rod 18, then channel 500 would “displace” laterally along rod 18. *See* Tr. 40: 3–11. This argument was made for the first time at the oral hearing with no meaningful opportunity for Petitioner to respond with evidence. *See Dell, Inc. v. Accelaron LLC*, 818 F.3d 1293, 1301 (Fed. Cir. 2016) (holding that arguments presented for the first time in a PTAB oral hearing, without prior notice of the argument, improperly deny opponent a meaningful opportunity to respond).

movement about rod 18, this would have suggested to a person of ordinary skill in the art that the hole is larger in diameter to permit the channel 500 to swing or pivot freely (i.e., to allow it to pivot with little or no resistance by the pivot mechanism). *See* Ex. 1002 ¶¶ 74, 142 (“Indeed engineering guidelines such as ANSI Standard B4 .1-1967 specify that a hole must be larger than the shaft that goes through it when relative motion is desired between the parts.”). Accordingly, we determine the record supports Petitioner’s contention that Schnuckle ’455 teaches or suggests the limitations of claim 4.

Before reaching our legal conclusion as to whether claims 2–4, 14, 20, and 22 are unpatentable as obvious, we turn to Patent Owner’s arguments based on objective indicia of non-obviousness.

6. *Objective Indicia of Non-obviousness*

Factual inquiries for an obviousness determination include secondary considerations based on evaluation and crediting of objective evidence of nonobviousness. *Graham v. John Deere Co.*, 383 U.S. 1, 17–18 (1966). The totality of the evidence submitted, including objective evidence of nonobviousness, may lead to a conclusion that the challenged claims would not have been obvious to one of ordinary skill in the art. *In re Piasecki*, 745 F.2d 1468, 1471–72 (Fed. Cir. 1984).

Secondary considerations may include any of the following: long-felt but unsolved needs, failure of others, unexpected results, commercial success, copying, licensing, and praise. *See Graham*, 383 U.S. at 17; *Leapfrog*, 485 F.3d at 1162. However, to be given substantial weight, there must be a nexus between the merits of the claimed invention and the evidence of secondary considerations. *In re GPAC Inc.*, 57 F.3d 1573, 1580

(Fed. Cir. 1995). “Nexus” is a legally and factually sufficient connection between the objective evidence and the claimed invention, such that the objective evidence should be considered in determining nonobviousness. *Demaco Corp. v. F. Von Langsdorff Licensing Ltd.*, 851 F.2d 1387, 1392 (Fed. Cir. 1988).

In its Response, Patent Owner presents evidence and arguments as to long-felt need, commercial success, industry praise, licensing, and copying. PO Resp. 52–57.

a. Long-Felt Need

Patent Owner contends “[t]he public has long sought artificial candles that can simulate a natural flickering flame.” PO Resp. 53. As an example, Patent Owner cites Wiklund (Ex. 1006), which, according to the ’166 patent (Ex. 2005, 1:66–2:19) could not convincingly reproduce a real or natural flame. *Id.* The ’166 patent addressed this need by providing devices that realistically reproduced the chaotic movement of natural flame. PO Resp. 53 (citing Ex. 2010 ¶¶ 144–145). Patent Owner contends this need has nexus to the innovative aspects of the challenged claims, i.e. “the improved ‘pleasing and realistic simulation of solitary flames’ achieved by the pivotal mounting structures and the corresponding chaotic movement they produce.” *Id.* (citing Ex. 2005, 1:63–64).

To be relevant, the proffered evidence must show a long-felt need *recognized by those of ordinary skill in the art.* *In re Gershon*, 372 F.2d 535, 538 (CCPA 1967). Reliance solely on the specification of the challenged patent is only probative of the inventors’ recognition of a problem and, if anything, demonstrates that the problem is not a serious one. *Id.* In this case, because the only proffered evidence of the alleged long-felt

need are the inventors' statements in the '166 patent, the evidence of long-felt need is weak at best.

We also consider Patent Owner's contention that a nexus exists between the claimed invention and the alleged long-felt need. PO Resp. 52–53. According to Petitioner, Patent Owner only argues a nexus to the realistic flame effect, which was known the in the prior art before the '166 patent. Pet. Reply 24.

“A nexus may not exist where, for example, the merits of the claimed invention were ‘readily available in the prior art.’” *ClassCo, Inc. v. Apple, Inc.*, 838 F.3d 1214, 1220 (Fed. Cir. 2016) (quoting *Richdel Inc. v. Sunspool Corp.*, 714 F.2d 1573, 1580 (Fed. Cir. 1983)) (holding that the Board properly gave no weight to evidence relating to features disclosed in the proposed combination). However, while a nexus may be lacking if it “exclusively relates to a feature that was ‘known in the prior art,’ the obviousness inquiry centers on whether ‘the claimed invention as a whole’ would have been obvious.” *WBIP, LLC v. Kohler Co.*, 829 F.3d 1317, 1329–32 (Fed. Cir. 2016) (quoting *Rambus, Inc. v. Rea*, 731 F.3d 1248, 1257 (Fed. Cir. 2013)).

In *WBIP*—an appeal from a denial of JMOL of obviousness—the Federal Circuit found that the patentee was entitled to a presumption of nexus, based on its showing that its products were embodiments of the claimed invention. *Id.* at 1330–31. The challenger argued that a nexus did not exist because objective indicia evidence (i.e., reducing carbon monoxide emissions) was “not tied to the elements in the claims that were missing from [the prior art,] Phipps,” namely a catalyst. *Id.* The court disagreed. Noting that there was testimony that Phipps alone could not “reduce carbon



monoxide emissions *without the addition of a catalyst*,” it stated that the inquiry must focus on the invention as a whole. *Id.* at 1331–32. Because the invention as a whole was sufficiently linked to the *combination* of known elements with the allegedly new element (i.e., the catalyst), the court concluded the jury’s presumed factual findings relating to nexus were supported by substantial evidence. *Id.* at 1332.

Here, according to Patent Owner, the alleged long-felt need is addressed by chaotic pivoting of the flame element to “reproduce a real or natural flame.” PO Resp. 53. According to Patent Owner, this “evidence of long-felt need has nexus to the innovative aspects of the challenged claims—namely the improved ‘pleasing and realistic simulation of solitary flames.’” *Id.* However, as discussed above, Schnuckle ’455 discloses that the “natural and chaotic” forces cause the flame element to move “randomly simulating blowing in the wind.” Ex. 1003, 6:53–62. Schnuckle ’455 also states that the system “includes an apparatus and a method for synthesizing an artificial flame that provides a *realistic flickering flame effect* that is safe and easy to manufacture.” *Id.* at 1:55–58 (emphasis added).

Consequently, in contrast to *WBIP*, we determine that the record supports the conclusion that the allegedly inventive features relied upon by Patent Owner of the claimed invention as a whole are disclosed *as a whole* by Schnuckle ’455. Patent Owner makes no effort, for example, to differentiate between the realistic flame effect of the current invention and identical disclosures in Schnuckle ’455. Accordingly, we find that insufficient nexus has been established between the alleged long-felt need and the claimed invention. For this additional reason, we give little weight to Patent Owner’s long-felt need argument.

b. Commercial Success

Patent Owner contends it has enjoyed significant commercial success, directly attributable to its “flameless candles that are covered by the challenged independent claims of each of the ’166, ’319, and ’869 patents.” PO Resp. 53. Patent Owner relies on Dr. Brown (Ex. 2010 ¶¶ 144–145) and a claim chart he provided (Ex. 2017) to demonstrate that the independent claims read on the commercial embodiment. *Id.* at 53–54. Patent Owner relies on Dr. Gorowsky (Ex. 2036 ¶¶ 3–6) for evidence that the product sales figures are attributable to the commercial embodiment. *Id.* at 54.

We have reviewed this evidence and testimony, and we find it does not demonstrate commercial success. At the outset, a necessary component of the commercial success inquiry is determining market share associated with the alleged product, relative to competing products. *In re Applied Materials, Inc.*, 692 F.3d 1289, 1300 (Fed. Cir. 2012). In this case, Patent Owner provides only raw sales (*see* Ex. 2020) of products allegedly embodying the independent claims as evidence of commercial success. *See* Ex. 2036 ¶¶ 3–6. Without market share, or a sense of the total market, we have no point of reference with which to evaluate the significance of the proffered sales amounts. *Applied Materials*, 692 F.3d at 1300 (“[T]he number of units sold without evidence of the market share is only weak evidence of commercial success.”).

Moreover, similar to the deficiency identified above, Patent Owner again relies on features found in the prior art to demonstrate nexus to commercial success. Specifically, Patent Owner’s evidence establishes, at most, that its commercial embodiments cover the required chaotic pivoting and realistic flame effect, which we determined to be disclosed by

Schnuckle '455. *See* Ex. 2017; Ex. 2010 ¶¶ 144–145 (“As shown in Exhibit 2017, I have mapped out how each feature of each *independent* claim corresponds to an aspect of the commercial embodiment.” (emphasis added)). As with long-felt need, Patent Owner fails to differentiate between the realistic flame effect of the current invention and comparable disclosures in Schnuckle '455. As such, this evidence is insufficient, as it can only establish success based on “features that were [available] in the prior art.” *ClassCo*, 838 F.3d at 1220; *see also Ormco Corp. v. Align Tech., Inc.*, 463 F.3d 1299, 1312 (Fed. Cir. 2006) (holding that evidence that commercial success was due to unclaimed or non-novel features of a device “clearly rebuts the presumption that [the product’s] success was due to the claimed and novel features”).

We have considered Patent Owner’s argument that customers favor and perhaps pay as much as twice the price of conventional “*flash-bulb*” flameless candles (*see* PO Resp. 54–55), but we do not find it persuasive because it, too, is linked either to the “realistic flame effect” or the chaotic pivoting disclosed in the prior art. Accordingly, for these additional reasons, we give little weight to Patent Owner’s commercial success argument.

c. Praise

We have reviewed Patent Owner’s arguments regarding industry praise and, for reasons similar to those discussed above, determine that these, too, are entitled little weight. Patent Owner relies on a video praising Patent Owner’s product at the “Consumer Electronics Show in January 2010” (Ex. 2024<sup>18</sup>) and an article praising the products allegedly copying the

---

<sup>18</sup> Patent Owner also cites Ex. 2018, which is its own contention interrogatory responses from related litigation. *See* PO Resp. 52 (identifying

patented technology (Ex. 2025). PO Resp. 36. Regardless, the evidence allegedly relates to “superior realistic flickering flame effect enabled by simulating chaotic motion.” *Id.*; *see also* Ex. 2025 (“The wick actually moves, not just the light flickering. That[’s] what gives it a real look, authenticity.”). In other words, similar to the deficiencies identified above with respect to long-felt need, the evidence at most provides a nexus only to the prior art chaotic pivoting disclosed in Schnuckle ’455, and insufficient nexus to the claimed invention.

d. Licensing

Patent Owner contends it has successfully licensed the ’319 patent to Candella and its successor, Luminara. PO Resp. 55 (citing Ex. 2026). According to Patent Owner, Luminara’s moving flame flameless candles embodying innovative aspects of the claimed technology have been sold through distributors and nationally-recognized retailers. *Id.* at 55–56 (citing Ex. 2028). Patent Owner also contends Petitioner agreed to pay Candella an 18% royalty under an agreement for use of the patented technology and thereafter, in 2012, sought a license directly from Disney. *Id.* at 56 (citing Ex. 2027; Ex. 2029).

We have reviewed this evidence and testimony, and we find it provides little relevant evidence of non-obviousness. At the outset, we discount Luminara’s distribution agreements (Ex. 2028) evidence, because

---

Ex. 2018 as “*arguments* in the parallel district court proceeding” (emphasis added)). Patent Owner’s own arguments are not evidence; citing to them as such is an improper attempt to incorporate additional briefing by reference. *See* 37 C.F.R. § 42.6(a)(3). To the extent evidence is cited in Ex. 2018, but not filed and cited in the papers of these proceedings, it has not been considered.

these do not purport to be “[l]icenses taken under the patent in suit,” and, therefore, do not demonstrate a nexus to the claimed invention. *See GPAC*, 57 F.3d at 1580. We also give little weight to the unsuccessful attempt by Petitioner to obtain a license from Patent Owner during litigation. *See Ex. 2029*. Licenses intended to resolve litigation disputes are not strong evidence of non-obviousness because “it is often cheaper to take licenses than to defend infringement suits.” *In re Cree, Inc.*, 818 F.3d 694, 703 (Fed. Cir. 2016) (internal quotes omitted). Here, in addition to not identifying the specific patent at issue or its applications, the unexecuted license between the parties purports to “resolve [the parties’] disputes.” *See Ex. 2029*, 26. As such, we give it little weight.

Of greater relevance, Patent Owner has presented what appears to be a series of executed license agreements between Luminara and Disney dating back to May 1, 2008 (Ex. 2026), of which the October 31, 2012 amendment purports to relate to the related ’319 patent at issue in IPR2015-01656. *See id.* at 19, 26 (listing the ’319 patent). Patent Owner does not direct us to how this agreement relates specifically to the challenged claims here, as opposed to other patents identified in the agreements or the prior art chaotic pivoting and realistic flame effect. Indeed, we observe that the earliest version of the license has an effective date of May 1, 2008, which is prior to the earliest priority date of the ’869 patent. *See id.* at 1. This earlier agreement lists only the prior art Schnuckle ’455 patent under “Licensed Patents.” *See id.* at 2. Taken as a whole, therefore, this license is more broadly indicative of Luminara’s desire to obtain Disney’s “Artificial Flame Technology” (*id.* at 1) going back to Schnuckle ’455, than any inventive features of the challenged claims here. As such, there is insufficient nexus

to the claims at issue here for this evidence to be given more than little weight. *See Cree*, 818 F.3d at 694 (finding broad licenses covering multiple patents as not having sufficient nexus).

e. Copying

With regard to copying, Patent Owner's contentions in full are as follows:

[Petitioner] Liown made specific efforts to reverse-engineer and replicate [Patent Owner] Luminara's products, specifically the innovative feature of chaotic pivoting at the location of the flame element. (Ex. 2030; Ex. 2029.) Liown did so after a failed attempt to access the technology through a manufacturing agreement with Luminara's predecessor, Candella. (Ex. 2029.) Copies of Luminara's patented flameless candles include the innovative features that enable chaotic pivoting of the flame element. (*See, e.g.*, Ex. 2030 at 5–9; Ex. 2029 at 4, 24–25, 32–40, 49–51.) The companies that copied Luminara's patented flameless candles did so with exactitude, with an apparent intent to copy and coopt the consumer demand associated with Luminara's products based on the ability to provide a more realistic flickering flame effect. (*Id.*)

PO Resp. 56–57 (citations to Ex. 2018 omitted).<sup>19</sup>

In considering these contentions, we make several observations. First, the cited pages 5–9 of Exhibit 2030 appear to be part of a declaration submitted by Patent Owner in a district court infringement suit contending that “Liown's flameless candle” practices claim 1 of the '166 patent. *See id.* Petitioner does not address this Exhibit or deny that the cited portions depict its product. *See* Pet. Reply 28–29. Second, Petitioner also does not deny Patent Owner's contention that Exhibit 2029 includes an attempted

---

<sup>19</sup> As noted above, the arguments Patent Owner's Interrogatory Responses are not considered. *See* 37 C.F.R. § 42.6(a)(3).

manufacturing agreement between Candella (i.e. Patent Owner's predecessor) and Petitioner. *See id.*

Third, we observe that Exhibit 2029 is a 51-page compilation of draft agreements, emails, CAD drawings, foreign and U.S. patents, a letter, product photographs, and an advertisement. Of this compilation, Patent Owner directs us to pages 4, 24–25, 32–40, and 49–51. These cites include CAD drawings, two untranslated pages of a Chinese patent, a U.S. patent, and the photographs of finished products. Other than the contentions reproduced above, Patent Owner provides no further explanation as to how these disparate documents are connected with each other, much less interpreted as evidence of copying. Accordingly, other than the CAD drawings, which Petitioner specifically addresses in its Reply, and the attempted agreement, Patent Owner has failed to demonstrate sufficiently that the other documents in the Exhibit 2029 compilation are evidence of copying.

Based on these observations, we assume *arguendo* that the depicted single-pendulum product in Exhibit 2030's claim chart is Petitioner's product.<sup>20</sup> As an initial matter, Petitioner does not deny that it had access to Patent Owner's CAD drawings during the relevant time frame. *See Wyers v. Master Lock Co.*, 616 F.3d 1231, 1246 (Fed. Cir. 2010) (noting that copying requires access and substantial similarity to the patented product). Although not pointed out to us by Patent Owner, we do note that there are similarities

---

<sup>20</sup> We do not consider the mapping of Petitioner's product to claim 1 as evidence of copying. *See Iron Grip Barbell Co., Inc. v. USA Sports, Inc.*, 392 F.3d 1317, 1325 (Fed. Cir. 2004) (holding that alleged infringement is not evidence of copying).

between the unannotated drawings and Petitioner's product, including similar angled lighting components and a wire-based pivotal mounting. *Compare* Ex. 2029, 4 *with* Ex. 2030, 3. On the other hand, we cannot clearly discern from the photographs whether Petitioner's pendulum is closely similar to Patent Owner's drawing or whether Patent Owner is using a two-stage pendulum with two wire supports as opposed to Petitioner's single-stage pendulum. *Compare* Ex. 2029, 4–5 *with* Ex. 2030, 3.

Based on the foregoing, we determine the evidence supports some degree of copying. However, without further analysis by Patent Owner and the uncertainties identified above, we do not find the evidence to be particularly substantial.

#### 7. Legal Conclusion

We have considered Patent Owner's evidence of non-obviousness against Petitioner's showing above that the subject matter of claims 2–4, 14, 20, and 22 would have been obvious in view of Schnuckle '455. We found the evidence supports giving the proposed objective indicia of non-obviousness little weight overall. Although the copying evidence is somewhat stronger, we note “that a showing of copying is only equivocal evidence of non-obviousness in the absence of more compelling objective indicia of other secondary considerations,” *Ecolchem, Inc. v. Southern California Edison Co.*, 227 F.3d 1361, 1380 (Fed. Cir. 2000), which we did not find here. Considering the evidence as a whole, including Petitioner's rationale for modifying Schnuckle '455 to obtain the limitations of claims 2–4, 14, 20, and 22, we are persuaded that Petitioner has established by a preponderance of the evidence that claims 2–4, 14, 20, and 22 are unpatentable as obvious over Schnuckle '455.



*E. Obviousness of Claims 18, 19, and 26  
over Schnuckle '455 and Helmer*

Petitioner argues that claims 18, 19, and 26 of the '166 patent are unpatentable, under 35 U.S.C. § 103(a), as obvious over Schnuckle '455 and Helmer. *See* Pet. 26–34. We have reviewed the Petition, Patent Owner's Response, Petitioner's Reply, as well as the relevant evidence discussed in those papers and other record papers. As described in further detail below, we determine that the record supports Petitioner's contentions that claims 18, 19, and 26, would have been obvious over Schnuckle '455 and Helmer, and we adopt Petitioner's analysis discussed below as our own. For reasons that follow, we determine that Petitioner has shown by a preponderance of the evidence that claims 18, 19, and 26 of the '166 patent would have been obvious over Schnuckle '455 and Helmer.

*1. Helmer (Ex. 1005)*

Helmer describes a toy that includes a jointed figure (e.g., a dancer or acrobat) and a structure for supporting the jointed figure but not interfering with its free movement. Ex. 1005, 1:8–18. Figures 1 and 4 of Helmer are reproduced below:

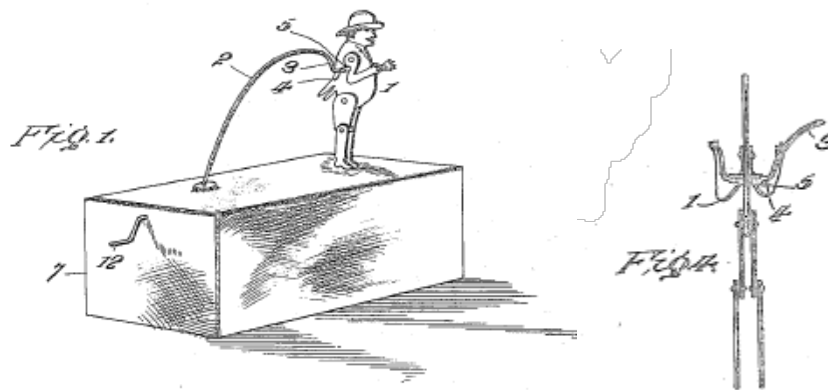

Figure 1 of Helmer is an embodiment of the dancing toy invention. Figure 4 provides a detailed view of the spring support. In Helmer, the crank 12 is

turned to cause movement of jointed figure 1, which freely oscillates, but is retained in place upon the horizontal portion 4 of support wire 2. Ex. 1005, 1:53–69, Fig. 4.

2. Claim 18

Claim 18 requires the support member to be “substantially rigid, whereby the support wire is stationary when the flame body moves within the interior space.” Petitioner contends Helmer’s wire support, bent downward at 3 and extending horizontally at 4 could be attached to the housing at each end in place of the gimbal to support channel 500 in Schnuckle ’455’s single-channel embodiment. Pet. 30–31 (citing Ex. 1005, 1:52–2:3, Figs. 1 & 4); Ex. 1002 ¶¶ 81–85. Petitioner contends such a “support wire would be rigid and remain stationary as channel 500 moves within the interior space of the imitation candle device of Fig. 12.” Pet. 32. Petitioner further contends that a person of ordinary skill in the art would have been motivated to combine Schnuckle ’455 and Helmer, as proposed, because such a structure would be simpler and less costly to manufacture than the gimbal, and would be more reliable than the gimbal to eliminate the risk that rod 18 would slip off ring-shaped member 20. Pet. 28 (citing Ex. 1002 ¶¶ 81–85).

As an initial matter, Patent Owner argues that, under the Board’s interpretation, the only element in Schnuckle ’455’s gimbal being substituted is rod 18. PO Resp. 39. We do not agree that Petitioner’s proposed modification is to replace the entire gimbal with Helmer’s support wire. See Pet. 27, 31; Ex. 1002 ¶¶ 84–85; Pet. Reply 13; Inst. Dec. 22 (stating Petitioner’s position regarding the wire support being less costly than the gimbal support); *id.* at 23 (noting that the substitution of Helmer

allows for movement about *one* axis as opposed to the *two* axis gimbal). Most of Patent Owner’s arguments on this issue proceed from this erroneous assumption, and are, therefore, not persuasive. *See e.g.*, PO Resp. 39–41 (“Assuming the proposed combination is to replace just rod 18 of Schnuckle with wire support 3 of Helmer . . .”).

a. “stationary”

Apart from the above-identified arguments, Patent Owner also contends Petitioners “conflate the meaning of ‘stout’ with the meaning of ‘stationary,’” which do not mean the same thing. PO Resp. 41. According to Patent Owner, Helmer discloses a “*spring-wire*” (*id.* at 42 (citing Ex. 1005, 1:45–50)), which may have the property of being stout, but would also move along with channel 500, when situated in Schnuckle ’455 rendering the proposed configuration non-stationary (*id.*). We disagree.

Patent Owner’s argument mistakenly assumes that the entire length of Helmer’s spring-wire is bodily incorporated into Schnuckle ’455. *See In re Keller*, 642 F.2d 413, 425 (CCPA 1981) (“The test for obviousness is not whether the features of a secondary reference may be bodily incorporated into the structure of the primary reference.”). Instead, we understand Petitioner to be relying on the section of the wire support, identified as 3 and 4 in Helmer, which is much shorter, as shown in Figure 4, reproduced above. *See* Pet. 30 (citing Ex. 1005, 1:52–2:3, Figs. 1, 4). Thus, the question is not whether the entire length of Helmer’s support wire 2 would vibrate in spring-like manner to impart movement from the platform to the figure, but rather whether the end of wire (i.e., Figure 4 (3, 4)), which *supports the figure* and is coupled to the housing in the proposed combination, would be non-stationary. We are persuaded that such a section of wire, connected to

the housing as Petitioner proposes (*id.*), would teach or suggest that the wire remains stationary when mounted in the housing of the artificial candle of Schnuckle '455.

Patent Owner's evidence to the contrary is Dr. Brown's Declaration (i.e., Ex. 2010 ¶ 98). In paragraph 98, Dr. Brown contends Helmer's spring (because of "its nature") would move. However, Helmer makes clear that the "spring-wire [is] *sufficiently stout to sustain the figure* without interfering in the least with its free movements." Ex. 1005, 1:47–50 (emphasis added). Thus, we credit Dr. Delson's rebuttal testimony that "the springiness and vibrations in []Helmer's wire, if any, are largely due to the long length and cantilevered configuration of the support. *A similar support wire of []Helmer in a shorter segment that are attached at both ends to candle housing would be substantially stiffer and can function as a rigid support of a swinging pendulum.*" Ex. 1019 ¶ 61 (emphasis added). We find Dr. Delson's testimony to be more credible on this issue than that of Dr. Brown because it is more consistent with the disclosures of Helmer and addresses Petitioner's contentions more accurately. Accordingly, for the foregoing reasons, we agree that a person of ordinary skill in the art would have understood that Helmer's support wire, as used in the combination, would be sufficiently rigid to remain stationary while supporting the moving pendulum member. We, therefore, find that the proposed combination teaches or suggests the limitations of claim 18.

b. Motivation to combine

Patent Owner also disputes Petitioner's rationale for combining Schnuckle '455 and Helmer as proposed. *See* PO Resp. 42–44. As an initial matter, we need not address Patent Owner's arguments as to why a person of

ordinary skill in the art would have replaced rod 18 of Schnuckle '455's two-axis gimbal, because, as noted above, this is not the modification Petitioner proposes. As to Petitioner's proposed modification—replacing the entire gimbal in Figure 12 with Helmer's support wire—Patent Owner contends this would “destroy Schnuckle's princip[le] of operation as relied upon by Petitioners.” *Id.* at 43. We have reviewed Dr. Brown's testimony cited by Patent Owner, but, except for one sentence in paragraph 92, this, too, is based on the belief that only rod 18 is replaced in Schnuckle '455. *See Ex. 2010 ¶ 92.* The one sentence of Dr. Brown's testimony is conclusory as it simply restates that the principle of operation would be destroyed, without elaboration. *See Ex. 2010 ¶ 92.*

Although unsupported, we have considered whether replacing the entire gimbal would destroy the principle of operation, and we find that it would not. As discussed above, replacing the two-axis gimbal in Figure 12 with Helmer's support wire would eliminate one of the two axes of rotation. Thus, the replacement would involve trade-offs, but, in this case, the trade-offs would be similar to those already contemplated by Schnuckle '455. *See also In re Urbanski*, 809 F.3d 1237, 1243 (Fed. Cir. 2016) (agreeing that a person of ordinary skill in the art would have been motivated to pursue the desirable qualities taught by one reference at the expense of foregoing the benefit taught by another reference). For example, Schnuckle '455 itself discloses a single-axis embodiment. *See Ex. 1003*, 6:7–8, Fig. 7, Fig. 8. Moreover, all embodiments of Schnuckle '455, including the single-axis embodiment of Figure 7, are designed to provide a realistic flame effect. *See Ex. 1003*, 2:1–3 (“[R]otation of the at least one channel about at least one axis of the mount creates an artificial flickering flame on the flame shaped

surface.”). Given these teachings, we do not find that the proposed combination would have destroyed Schnuckle ’455’s principle of operation. *See In re Mouttet*, 686 F.3d 1322, 1332 (Fed. Cir. 2012).

As to the rationale for combining Schnuckle ’455 and Helmer, based on reducing the number of components and reducing the possibility of the wire support slipping off the ring, Patent Owner’s arguments are again based on keeping parts of the gimbal structure, which is not the proposal. *See* PO Resp. 43 (“[I]f Schnuckle’s gimbal is kept even partially intact, modification of the gimbal would be even more costly and require the same number of parts. (Ex. 2010, Brown Decl. ¶¶ 99.)”). Dr. Brown makes similar statements in his Declaration. *See* Ex. 2010 ¶¶ 99. Petitioner’s cost and reliability rationales, based on replacing the *entire* gimbal, remain un rebutted.

We find Petitioner’s reasons for combining Schnuckle ’455 and Helmer to be sufficient and based on rational underpinning. *See KSR*, 550 U.S. at 418.

When there is a design need or market pressure to solve a problem and there are a finite number of identified, predictable solutions, a person of ordinary skill has good reason to pursue the known options within his or her technical grasp. If this leads to the anticipated success, it is likely the product not of innovation but of ordinary skill and common sense. *Id.* at 421. Here, we find that Petitioner has provided two reasons for why a person of ordinary skill in the art would have been motivated to identify a simpler pivotal mounting structure, such as used in Helmer, to replace the gimbal mechanism in Schnuckle ’455, based at least on cost and reliability. In view of the foregoing, we determine Petitioner has presented and sufficiently established an “articulated reasoning with some rational

underpinning to support the legal conclusion of obviousness” with respect to combination of Schnuckle ’455 and Helmer, and we adopt its contentions as our own. *Id.* at 418 (quoting *In re Kahn*, 441 F.3d 977, 988 (Fed. Cir. 2006)).

3. Claims 19 and 26

Claim 19 requires that the support member be “shaped to include a low spot or valley between first and second ends coupled to the housing, whereby the flame body rests within the low spot or valley of the support member.” Claim 26 requires a similar “low spot or valley.” Petitioner contends Helmer’s wire support includes a horizontally extended low spot or valley (see Ex. 1005, Fig. 4 (3)), for hanging or balancing a pendulum-like element. Pet. 27, 30, 32–33. Petitioner contends, therefore, that the proposed combination, including Helmer’s low spot, teaches or suggests this limitation in claim 19 and 26. Patent Owner does not dispute this analysis, which we find persuasive and adopt as our own.

For the first three limitations of independent claim 26, Petitioner provides a similar mapping as it did for substantially similar limitations of claims 1 and 13. *See* Pet. 29–30. Patent Owner does not separately challenge Petitioner’s showing for claim 26, except to contend that Helmer does not allow chaotic pivoting. PO Resp. 48. However, again, Patent Owner’s arguments are based on the mistaken assumption that only rod 18 is replaced by Helmer and not the entire gimbal. *See id.* at 48–50.

We have considered whether the proposed combination of Schnuckle ’455 and Helmer teaches chaotic pivoting, and conclude that it does. As discussed above in our analysis of the disclaimer of non-chaotic pivoting, we rejected a multi-axis movement requirement for chaotic

pivoting, as motion can be chaotic with one axis of rotation. *See also Luminara*, 814 F.3d at 1353 (“Pivoting includes rotation around a single axis.”). Dr. Delson also testifies that a single-axis of rotation is sufficient to exhibit chaotic motion in a plane. Ex. 1019 ¶¶ 16–17, 27 (“Fig[ure] 7 has key components necessary for chaotic motion; dimensionality greater than 2 and nonlinear coupling.”). We credit this testimony. For example, although the Schnuckle ’455 Figure 7 embodiment includes a single axis gimbal (*see* Ex. 1003, Fig. 7 & 8, 2:1–3 (rotation about at least one axis)), all embodiments are described as providing a *realistic flame effect*. *See* Ex. 1003, 1:54–58. Similarly, Helmer discloses that the figure, balanced on supporting-arm 4 is free to oscillate “so as to add materially to the grotesqueness of its actions.” Ex. 1005, 1:56–69. We determine Schnuckle ’455’s natural and chaotic driving force combined with Helmer’s rotation teaches or suggests chaotic pivoting.

For the foregoing reasons, we find the Schnuckle ’455 and Helmer combination teaches all of the limitations of claims 19 and 26.

#### 4. Legal Conclusion

We have considered Patent Owner’s evidence of non-obviousness,<sup>21</sup> which we accord little weight for the reasons discussed above, against Petitioner’s showing above that the subject matter of claims 18, 19, and 26 would have been obvious in view of Schnuckle ’455 and Helmer. Considering the evidence as a whole, including Petitioner’s rationale for modifying Schnuckle ’455 with Helmer to obtain the limitations of claims

---

<sup>21</sup> Including Patent Owner’s contentions regarding objective indicia of non-obviousness discussed above, which apply to all of the grounds of unpatentability based on non-obviousness.



18, 19, and 26, we are persuaded that Petitioner has established by a preponderance of the evidence that claims 18, 19, and 26 are unpatentable as obvious over Schnuckle '455 and Helmer.

*F. Obviousness of Claim 7 by Schnuckle '455  
and Cornell*

Petitioner argues that claim 7 of the '166 patent is unpatentable, under 35 U.S.C. § 103(a), as obvious over Schnuckle '455 and Cornell. *See* Pet. 34–36. We have reviewed the Petition, Patent Owner's Response, Petitioner's Reply, as well as the relevant evidence discussed in those papers and other record papers. As described in further detail below, we determine that the record supports Petitioner's contentions for claim 7 as obvious over Schnuckle '455 and Cornell, and we adopt Petitioner's analysis discussed below as our own. For reasons that follow, we determine that Petitioner has shown by a preponderance of the evidence that claim 7 of the '166 patent is obvious over Schnuckle '455 and Cornell.

*1. Cornell (Ex. 1004)*

Cornell describes an artificial fireplace. Ex. 1004, Title, 1:15–18.

Figure 3 of Cornell is reproduced below:

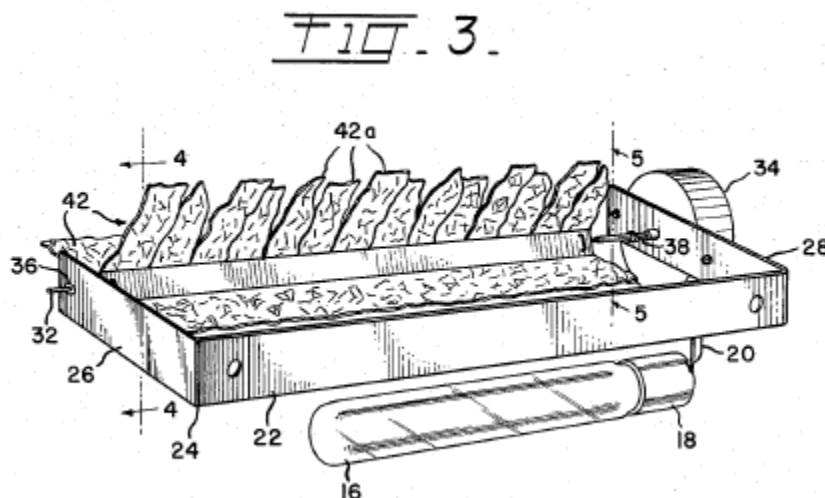

Figure 3 of Cornell shows an embodiment of the artificial fireplace invention. Specifically, Figure 3 includes “light-deflecting blades of irregular configuration” 42 to reflect light to produce the appearance of “flickering flames.” *Id.* at 1:32–40, 2:45–46. The blades are made of foil or other highly reflective material “distorted or wrinkled to provide irregularly oriented reflecting surfaces that will reflect light from the bulb 16 in a random fashion . . . .” *Id.* at 2:45–51.

2. Claim 7

Claim 7 recites that the “surface of the flame silhouette element is recessed.” Petitioner contends Cornell’s distorted and wrinkled flame-like surfaces have “recessed areas.” Pet. 35 (citing Ex. 1004, 2:45–51). Petitioner contends a person of ordinary skill in the art would have recognized that such distorted, wrinkled flame elements in Cornell could be applied to the flame silhouette element in Schnuckle ’455 “to improve the flickering effect.” *Id.* at 35–36; Ex. 1002 ¶¶ 103–108. Consequently, Petitioner contends, the combination of Schnuckle ’455 and Cornell teaches or suggests a flame silhouette element that is recessed, as claim 7 requires. Pet. 35–36. Patent Owner does not specifically dispute these contentions. We agree that Cornell’s disclosure of “blades 42 . . . made of metal foil or other similar light-weight, highly reflective material, and are distorted or wrinkled to provide irregularly oriented surfaces that will reflect light . . . in a random fashion” (Ex. 1004, 2:45–51) teaches a flame silhouette element with recessed areas. We also agree with Petitioner and Dr. Delson that a person of ordinary skill in the art would have been motivated to use Cornell’s blades to improve the flickering appearance of the candle in

Schnuckle '455. *See* Ex. 1002 ¶ 107. Accordingly, we adopt Petitioner's analysis as our own.

3. *Legal Conclusion*

We have considered Patent Owner's evidence of non-obviousness, which we accord little weight for the reasons discussed above, against Petitioner's showing above that the subject matter of claim 7 is obvious in view of Schnuckle '455 and Cornell. Considering the evidence as a whole, including Petitioner's rationale for modifying Schnuckle '455 with Cornell to obtain the limitations of claim 7, we are persuaded that Petitioner has established by a preponderance of the evidence that claim 7 is unpatentable as obvious over Schnuckle '455 and Cornell.

*G. Obviousness of Claims 1–4, 13, 14, 18, 20,  
and 22 by Wiklund and Baba*

Petitioner argues that claims 1–4, 13, 14, 18, 20, and 22 of the '166 patent are unpatentable, under 35 U.S.C. § 103(a), as obvious over Wiklund and Baba. *See* Pet. 36–48. We have reviewed the Petition, Patent Owner's Response, Petitioner's Reply, as well as the relevant evidence discussed in those papers and other record papers. As described in further detail below, we determine that the record supports Petitioner's contentions for claims 1–4, 13, 14, 18, 20, and 22, as obvious over Wiklund and Baba, and we adopt Petitioner's analysis discussed below as our own. For reasons that follow, we determine that Petitioner has shown by a preponderance of the evidence that claims 1–4, 13, 14, 18, 20, and 22 of the '166 patent would have been obvious over Wiklund and Baba.

1. Wiklund (Ex. 1006)

Wiklund describes a mechanism for an imitation candle. Ex. 1006, Title, Abstract, Fig. 1. Figure 1 is reproduced below:

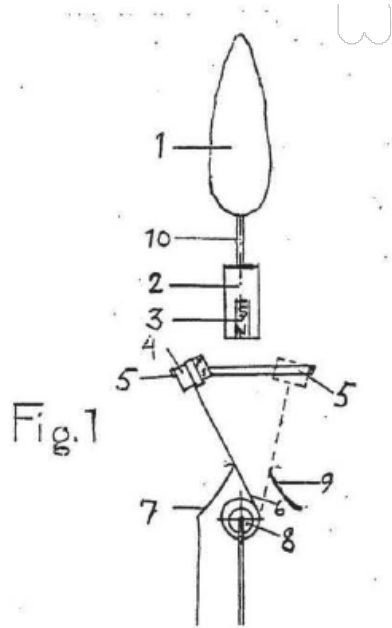
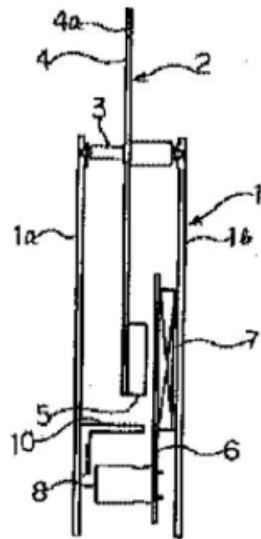

Figure 1 above illustrates an imitation candle mechanism as described in Wiklund. As shown in Figure 1, electric light 1 is mounted on pendulum 2, which has magnet 3 mounted at its opposite end. Ex. 1006, 1:23–31. The mechanism also consists of spring 6 with magnet 4 at its free end. *Id.* at 2:1–2. Magnet 4 moves in response to the heating and cooling of spring 6. *Id.* at 2:15–16. As magnet 4 moves, it repels magnet 3 causing motion in pendulum and bulb, which “gives the illusion of a ‘living’ candle flame affected by air draught.” *Id.* at 2:3–6.

2. Baba (Ex. 1008)

Baba describes a “pendulum driver which enables a pendulum to swing with an irregular period” for use in decorative pendulums or displays. Ex. 1008, Abstract, ¶ 4. Figures 1 and 2 are reproduced below:

[Fig. 1]



[Fig. 2]

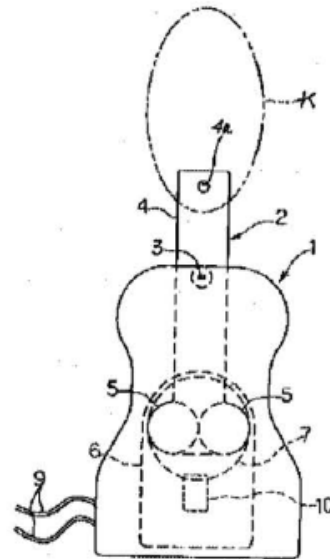

Figures 1 and 2 illustrate a pendulum driver as described in Baba. In Figures 1 and 2, pendulum 2 includes “swing-beam” 4, with magnets 5 mounted at its lower end, and is mounted on support shaft 3. *Id.* ¶ 8. An ornament “K” is attached to the upper end of the swing-beam at 4a. *Id.* ¶¶ 8, 12.

Controlled electricity is supplied to coil 7, which, in conjunction with magnetic member 10, causes irregular oscillations in pendulum 2. *Id.* ¶¶ 12, 14. The pendulum driver can be used as a decorative pendulum for displays, clocks, and a “wide range of applications.” *Id.* ¶ 18.

### 3. Claims 1 and 13

Petitioner provides a proposed mapping of the combination of Wiklund and Baba to claims 1 and 13 of the '166 patent. Pet. 39–43. Petitioner contends both Wiklund and Baba disclose “a pendulum member for generating a flickering flame effect” (*id.* at 39); “a body with upper and lower portions” (*id.*); and “a flame silhouette element” (*id.* at 40), as recited in claim 1. Petitioner further contends Baba’s description of a “hole in

swing beam 4, below the ornament, for receiving support shaft 3” discloses the required “hole in the body . . . configured to receive a flame support element such that . . . the body is free to pivot when supported by the flame support element.” *Id.* at 40 (citing Ex. 1008 ¶¶ 8, 12, Figs. 1, 2). Petitioner provides a similar mapping for the limitations of independent claim 13. Pet. 41–43. According to Petitioner, a person of ordinary skill in the art would have recognized “that having a pendulum that swings with an irregular period can be useful in emulating a more desirable movement of an object for a decorative or ornamental imitation candle device,” and, therefore, would have used Baba’s magnetically driven pendulum for Wiklund’s imitation candle. *Id.* at 38–39; *see also* Ex. 1002, 114.

Patent Owner contends the proposed combination does not teach or suggest a “hole” or “chaotic pivoting,” as required by claims 1 and 13, and Petitioner’s reason to combine Wiklund and Baba is defective. PO Resp. 21–28.

a. “hole” or “pivot hole”

Patent Owner contends that Petitioner’s reliance on Baba’s description of “pendulum 2 [that] includes a strip-like swing beam 4 [that is] swingably supported by the case 1 via the supporting shaft 3,” (*id.* at 21 (quoting Ex. 1008 ¶ 8 (bracketed text added by Patent Owner))), as illustrated in Figures 1 and 2, does not “explicitly disclose a *hole* in swing beam 4 for receiving shaft 3” (*id.* at 22 (citing Ex. 2010 ¶¶ 61–62)). We disagree.

As an initial matter, whether or not Baba “explicitly discloses” a hole is not the relevant test. *Keller*, 642 F.2d at 426 (“The test for obviousness is not . . . that the claimed invention must be *expressly* suggested in any one or all of the references.” (emphasis added)). Petitioner directs us to evidence

that swing beam 4 is “swingably supported” by shaft 3, the intersection of which is depicted by a circle in Figure 2 (see above) suggesting that shaft 3 extends through a hole in swing beam 4. Pet 40–41; Ex. 1002 ¶ 122. In addition, Dr. Delson directs us to the cross sectional view of swing beam 4 showing parallel lines, where the shaft is attached, and testifies that this is a standard way of representing a hole in a cross-sectional view. See Ex. 1019 ¶ 52.

Patent Owner contends, however, that it would not make sense for swing beam 4 to swing about shaft 3, because:

Figure 1 of Baba shows that shaft 3 is coupled to the front and rear plates of case 1 by a set of inset depressions, one on either side, into which the ends of shaft 3 are inserted and may rotate. (Ex. 2010, Brown Decl. ¶ 62.) A POSITA would have understood that any rotation would thus occur simultaneously at the intersection of shaft 3 and at the front and rear plates of case 1. (*Id.* at 63.) This reading is not contrary to the passage of Baba which states that “swing beam 4 swings around the supporting shaft 3.” (Ex. 1008, Baba ¶ 12.) Swing beam 4 can swing “around” shaft 3 without pivoting about the intersection of swing beam 4 and shaft 3. (Ex. 2010, Brown Decl. ¶ 63.) . . . *Rotation could not occur at all of these locations simultaneously because that type of arrangement would result in no displacement of swing beam 4, as rotation at one end of shaft 3 would be cancelled by rotation at its center.* (*Id.* at 63.)

PO Resp. 23–24 (emphasis added).

We do not find this argument persuasive. As Patent Owner acknowledges in the above quote, paragraph 12 of Baba states that “swing beam 4 swings *around* the supporting shaft 3” (emphasis added). We agree that this (and the fact that shaft 3 is “swingably supported”) suggests relative movement between swing beam 4 and shaft 3. Ex. 1019 ¶ 55. Patent Owner

bases its contention that shaft 3 rotates by pointing to “inset depressions” into which the ends of “shaft 3 are inserted and may rotate.” PO Resp. 23 (citing Ex. 2010 ¶ 62). We note, however, that this argument is based entirely on the Figure 1 depiction of the intersection between the shaft and the supporting structure (*see* Figure 1, reproduced above); there is no citation to a description in the text of Baba, and Baba does not mention inset depressions. We do not view Figure 1 as probative of whether shaft 3 rotates or not. Therefore, we find there is little suggestion that shaft 3 rotates.

In any event, even assuming shaft 3 itself rotates, based on alleged “inset depressions,” Patent Owner’s argument (i.e., that rotation at all locations at once would result in no displacement of swing beam 4) is accurate only if swing beam 4 is driven by shaft 3, which it is not. Swing beam 4 is driven by magnetic force imparted by driving coil 7, causing it to “swing around the supporting shaft 3” regardless of whether shaft 3 rotates or not. *See* Ex. 1008 ¶¶ 11–12; Ex. 1019 ¶ 55. Accordingly, we credit Dr. Delson’s testimony, and determine that Baba teaches or suggests a hole at the intersection of swing beam 4 and shaft 3.

b. “chaotic pivoting”

Patent Owner contends Baba does not teach chaotic pivoting at any location, because “[p]endular movement, even with an irregular period, does not meet the definition of chaotic behavior.” PO Resp. 24 (citing Ex. 2010 ¶¶ 64–66). Patent Owner’s arguments depend on Patent Owner’s interpretation of “chaotic pivoting” (i.e., sensitivity to initial conditions, multiple axes of rotation), which we do not adopt; thus, we are not persuaded.



Although we disagree with Patent Owner’s arguments, we nonetheless consider whether the Wiklund and Baba combination sufficiently discloses the pivot (or pivotally supported) limitation given the disclaimer of non-chaotic pivoting and devices driven by rhythmic and metronomic patterns. For the pendulum movement and driving mechanism, Petitioner relies on Baba. Pet 38, 41 (“In the Wiklund-Baba combination set forth above, the imitation candle device includes Baba’s swing beam with its hole for receiving the supporting shaft on which it is free to pivot. The hole would be located below the flame-like bulb that extends upward from the upper portion of the swing beam.”). Petitioner further relies on Baba’s swing beam movement “with an irregular period.” *Id.* (citing Ex. 1008, Abstract, ¶ 12); Ex. 1002 ¶ 113. Patent Owner contends Baba seeks to control the swinging motion by, for example, using “braking force to act on the oscillatory movement,” which are both contrary to the ’166 patent’s objectives.<sup>22</sup> PO Resp. 25 (citing, Ex. 1008 ¶ 5); Ex. 2010 ¶ 66.

We are persuaded by Petitioner’s arguments and evidence. As the Abstract and paragraph 14 of Baba make clear, the objective is to have the pendulum swing with an “irregular period.” As it is “irregular,” it teaches a non-metronomic and non-rhythmic driving force as our construction requires. Patent Owner’s evidence that Baba “controls” the pendulum with braking action (as does the ’166 patent (*see* Ex. 1001, 19:9–30 (emphasis added); *id.* at 18:55–64 (“[T]he kinetic movement . . . may be dampened . . . in response only to magnetic field M<sub>2</sub>.”))), is consistent with the view that Baba produces aperiodic motion. For example, Baba states that the

---

<sup>22</sup> For this reason, Patent Owner also argues Baba’s pendulum is not “free to pivot” as required by claim 14.

“permanent magnet enables braking force to act on the oscillatory movement . . . to intentionally change the amplitude of swing, which gives the movement of a pendulum the element of surprise.” Ex. 1008 ¶ 5 (emphasis added). Baba’s irregular and surprising movement is consistent with the ’166 patent’s use of the term chaotic interchangeably with unpredictable and random. Based on the foregoing, we agree that Baba’s magnetically driven pendulum with an irregular period teaches or suggests chaotic pivoting.

c. Motivation to combine

Patent Owner disputes Petitioner’s rationale for combining Wiklund and Baba as proposed. PO Resp. 26–28. As an initial matter, Patent Owner argues Petitioner fails to “properly frame the combination.” *Id.* at 26. We disagree. As discussed and shown graphically in the Petition, Petitioner relies on Baba’s swing beam, hole, support shaft, magnet and driving mechanism (including magnet 10), in combination with Wiklund’s “flame-like bulb” replacing the ornament in Baba. Pet. 40–41.

Patent Owner also argues a person of ordinary skill in the art would not have replaced Wiklund’s mechanism specifically designed to simulate a natural flame (Ex. 1006, 2:20–32), with Baba’s “less natural swing beam and shaft,” which is designed to attract attention to advertising displays (Ex. 1008 ¶¶ 2, 5). PO Resp. 27. According to Patent Owner, such a substitution would have been irrational because Wiklund is already designed to produce irregular motion, while Baba’s “‘irregular period’ is not described as natural, let alone more *natural* than Wiklund’s mechanism.” *Id.* at 27–28. In support of this, Patent Owner cites Wiklund’s “short oscillations” desirable for artificial flame devices (Ex. 1006, 2:22), in contrast to Baba’s “elongated” swing periods (Ex. 2010 ¶ 71). PO Resp. 28.

As a general matter, we find Petitioner’s articulated reasoning for combining Wiklund and Baba to be based on rational underpinning. As both parties acknowledge, Wiklund’s approach to irregular movement is based on heating and cooling a bimetal spring with an attached magnet, which acts on a pendulum having an attached magnet. Ex. 1006, 2:8–29; PO Resp. 27. Baba uses a circuit to generate a magnetic field to cause a pendulum having an attached magnet to swing in an irregular manner around supporting shaft 3 to give a display ornament an element of surprise. Ex. 1008 ¶¶ 10–12, 18. Dr. Delson testifies that a person of ordinary skill would have used Baba with a flame-like bulb as in Wiklund to more realistically simulate random movements of a candle flame. Ex. 1002 ¶ 114.

In its Response, Patent Owner cites Dr. Brown’s testimony that Baba’s elongated swing periods would be less natural. Ex. 2010 ¶ 71 (citing Ex. 1008 ¶ 14). However, Dr. Brown’s testimony is not supported by Baba. To the contrary, cited paragraph 14 actually describing pendulum attenuation as “elongation of the time for which braking force acts; *as a result the period, shortens*” (emphasis added). According to paragraph 18, “the irregular movement of the pendulum can be varied by controlling the supply of electricity to the driving coil or changing the position of the magnetic member to be disposed; thus, the present invention can be used in a wide range of applications.” *See also* Ex. 1008 ¶¶ 14–16 (explaining the placement of magnets and powering the coil to adjust amplitude and period). As such, to the extent modifications are necessary to adapt Baba to the particular application of the artificial candle, Baba instructs a person of ordinary skill in the art in how to make such adjustments. *See also Leapfrog*, 485 F.3d at 1162 (finding no evidence the proposed combination

would have been “uniquely challenging or difficult for one of ordinary skill in the art”). Accordingly, we determine that Petitioner’s rationale for combining Wiklund and Baba is supported by the evidence.

4. Claims 2, 3, and 18

Petitioner contends the combination of Wiklund and Baba teaches or suggests the limitations of claims 2, 3. Pet. 43–44. In its Response, Patent Owner does not address claims 2 or 3, or the Petitioner’s contentions. As for claim 18, we disagreed with Patent Owner’s claim 1 analysis that shaft 3 rotates, and, consequently, we disagree here with its argument that it is not “stationary” as required by claim 18 (*see id.* at 44–45). We determine the record supports Petitioner’s analysis with respect to these claims and, therefore, adopt them as our own.

5. Claims 4, 20, and 22

Petitioner contends the combination of Wiklund and Baba teaches or suggests the “elongated and planar” limitation of claim 4, because “Baba’s swing beam 4 is elongated and planar as clearly shown in both figures. Ex. 1008 ¶ 8, Figs. 1 & 2.” Pet. 45. We observe that paragraph 8 of Baba also supports this interpretation of Figures 1 and 2. *See* Ex. 1008 ¶ 8 (“strip-like swing beam 4”). Petitioner also relies on this evidence for claim 20’s elongated and planar limitation and provides evidence for the other limitations of claim 20. *Id.* at 47–48. Although Patent Owner contends claims 4 and 20 are patentable because “Schnuckle and Wiklund cannot be successfully modified as proposed” (PO Resp. 45–46), Patent Owner does not address the Wiklund and Baba combination for these claims. We determine the record supports Petitioner’s analysis with respect to these

undisputed claims (as well as claim 22, which depends from claim 20 and adds a limitation similar to claim 3) and, therefore, adopt it as our own.

6. Claim 14

Petitioner contends that the combination of Wiklund and Baba teaches or suggests claim 14's pivot hole is "larger in diameter than the exterior dimension of the support element, whereby the flame body swings or pivots freely about the support element." Pet. 45–46. Petitioner relies on evidence similar to that discussed above for claims 1 and 13, i.e., that because the swing beam (of Baba) is "swingably supported," a person of ordinary skill would have understood that the pivot hole in swing beam 4 is larger than the diameter of shaft 3. *Id.* (citing Ex. 1008 ¶¶ 7, 8, 11, Figs. 1–2; Ex. 1002 ¶¶ 142–144).

In addition to its contentions that Baba does not teach a hole (as required by claim 13), Patent Owner also relies on its contention, discussed above, that Baba's shaft 3 is secured using inset depressions, which allow shaft 3 to rotate. PO Resp. 35–36 (citing Ex. 2010 ¶ 85). Similar to its arguments regarding rod 18 of Schnuckle '455, discussed above, Patent Owner reasons that no rotation occurs at the intersection of swing beam 4 and shaft 3 and the inset locations, because any rotation at the ends of shaft 3 would be cancelled by rotation at its center resulting in no displacement. *Id.* For reasons similar to those discussed above, we do not find either of these arguments persuasive, because, even assuming shaft 3 rotates, there is no reason that both shaft and pendulum cannot rotate relative to each other.

Patent Owner also argues that, because Baba applies braking force to act on the oscillatory movement, Baba's beam is not "free to pivot" under the Board's construction (i.e., with little or no resistance). *Id.* at 37–38

(citing Ex. 1008 ¶ 5 (“[T]he magnetic force . . . enables braking force.”)). However, we determined that this interpretation of the construction was inconsistent with the ’166 patent’s use of magnetic force as a dampening force, and clarified our construction as “pivoting with little or no resistance *by the pivot mechanism.*” Therefore, we do not find Patent Owner’s braking force argument persuasive.

In the absence of persuasive rebuttal, we credit Dr. Delson testimony that ANSI engineering guidelines specify a larger hole (than the diameter of the shaft) to permit relative motion between the parts. Ex. 1002 ¶ 142. This is consistent with paragraph 12 of Baba, which states that “swing beam 4 swings *around* the supporting shaft 3” (emphasis added). We determine, therefore, that the evidence supports Petitioner’s contention that the hole must be larger than the diameter of the shaft to permit rotation by the shaft (i.e., to allow it to pivot with little or no resistance). Accordingly, we find that the combination of Wiklund and Baba teaches or suggests the limitation of claim 14.

#### 7. Legal Conclusion

We have considered Patent Owner’s evidence of non-obviousness, which we accord little weight for the reasons discussed above, against Petitioner’s showing above that the subject matter of claims 1–4, 13, 14, 18, 20, and 22 would have been obvious in view of Wiklund and Baba. Considering the evidence as a whole, including Petitioner’s rationale for modifying Wiklund and Baba to obtain the limitations of claims 1–4, 13, 14, 18, 20, and 22, we are persuaded that Petitioner has established by a preponderance of the evidence that claims 1–4, 13, 14, 18, 20, and 22 are unpatentable as obvious over Wiklund and Baba.

*H. Obviousness of Claims 19 and 26 by  
Wiklund, Baba and Meeker*

Petitioner argues that claims 19 and 26 of the '166 patent are unpatentable, under 35 U.S.C. § 103(a), as obvious over Wiklund, Baba, and Meeker. *See* Pet. 48–53. We have reviewed the Petition, Patent Owner's Response, Petitioner's Reply, as well as the relevant evidence discussed in those papers and other record papers. As described in further detail below, we determine that the record supports Petitioner's contentions for claims 19 and 26 as obvious over Wiklund, Baba, and Meeker, and we adopt Petitioner's analysis discussed below as our own. For reasons that follow, we determine that Petitioner has shown by a preponderance of the evidence that claims 19 and 26 of the '166 patent would have been obvious over Wiklund, Baba, and Meeker.

*1. Meeker (Ex. 1005)*

Meeker describes a toy that includes jointed Figure 7 made of sheet metal and supporting arm 6 from which the figure is suspended. Ex. 1005, 1:27–29, 42–46, 51–60. Figures 1 and 2 are reproduced below:

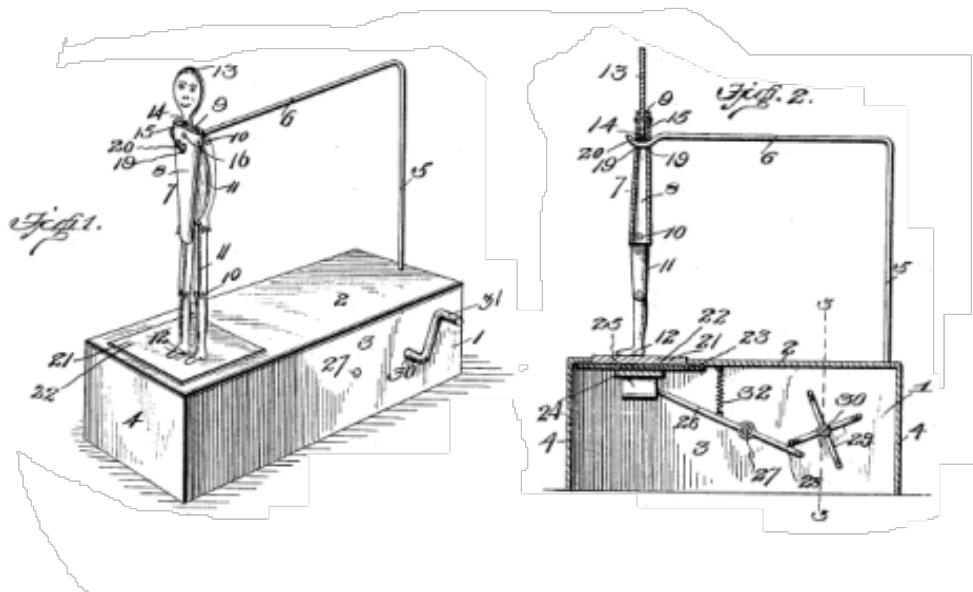

Figures 1 and 2 represent the dancing toy invention of Meeker. As shown in Figure 2, the toy figure rests in the downwardly curved portion 20 of supporting arm 6, which protrudes through hole 19 in the body. Ex. 1005, 1:67–75. This allows the body to swing transversely and longitudinally while remaining in place. *Id.* Turning crank 31 imparts motion upon “vibratory platform 21,” transmitting motion to the toy figure. *Id.* at 1:81–2:13.

2. Claims 19 and 26

Petitioner contends Meeker’s wire support includes a downwardly curved portion with a low point where the body of the dancing figure rests. Pet. 51–52 (citing Ex. 1009, 1:67–75, Fig. 1, 2). Thus, Petitioner contends, Meeker, in combination with Wiklund and Baba, teaches or suggests the recited “support member [that] is shaped to include a low spot ... whereby the pendulum member rests in the low spot or valley” in claim 26 (*id.* (emphasis omitted)) and the similar limitation of claim 19 (*id.* at 52–53). According to Petitioner, a person of ordinary skill in the art would be motivated to combine the references because the low spot or valley in Meeker’s support wire would keep the swing beam of Baba in position while allowing it to swing. *Id.* at 49; Ex. 1002 ¶ 157.

Patent Owner does not dispute that the combination teaches the recited low spot. For the first three limitations of independent claim 26, Petitioner provides a similar mapping, as it did for substantially similar limitations of claims 1 and 13. *See* Pet. 50–51. Patent Owner does not separately challenge Petitioner’s showing for claim 26, except to challenge the combination as discussed below.



Patent Owner contends a person of ordinary skill in the art, would not have replaced Baba's shaft 3 with Meeker's curved arm 6. PO Resp. 50–51 (citing Ex. 2010 ¶ 123). However, similar to its analysis of claim 1, Patent Owner bases this argument on its contentions that shaft 3 rotates, and, therefore, swing beam 4 does not rotate. *See id.* at 51 (“[T]he intersection of swing beam 4 and Meeker's arm . . . is already fixed in Baba.”). We found neither of these contentions to be persuasive. In addition, Patent Owner contends the addition of a low spot (as taught by Meeker) would require additional steps and is not the most straightforward way to keep Baba's swing beam in position. *Id.*; Ex. 2010 ¶ 123 (“A more obvious modification . . . would be to simply glue the swing arm in place.”). We do not find this argument persuasive, because, even accepting that a curved arm requires an additional step or there may be an easier modification, it does not negate Petitioner's contention that a person of ordinary skill would have added a low spot to allow for swing beam 4 to remain in position. *See Urbanski*, 809 F.3d at 1243. Accordingly, we find Petitioner's reason for combining Wiklund, Baba, and Meeker to be based on rational underpinnings.

### 3. Legal Conclusion

We have considered Patent Owner's evidence of non-obviousness, discussed above, against Petitioner's showing that the subject matter of claims 19 and 26 would have been obvious in view of Wiklund, Baba, and Meeker. Considering the evidence as a whole, including Petitioner's rationale for modifying Wiklund, Baba, and Meeker to obtain the limitations of claims 19 and 26, we are persuaded that Petitioner has established by a preponderance of the evidence that claims 19 and 26 are unpatentable as obvious over Wiklund, Baba, and Meeker.

*I. Anticipation of Claims 1–3 by Sandell*

Petitioner argues that claims 1–3 of the '166 patent are unpatentable, under 35 U.S.C. § 102(b), as anticipated by Sandell. *See* Pet. 55–58. We have reviewed the Petition, Patent Owner’s Response, Petitioner’s Reply, as well as the relevant evidence discussed in those papers and other record papers. As described in further detail below, we determine that the record does not support Petitioner’s contentions for claims 1–3 as anticipated by Sandell.

*1. Sandell (Ex. 1010)*

Sandell describes an “imitation candle with magnetic pendulum.”

Ex. 1010, Title, Abstract, Fig. 1. Figure 1 of Sandell is reproduced below:

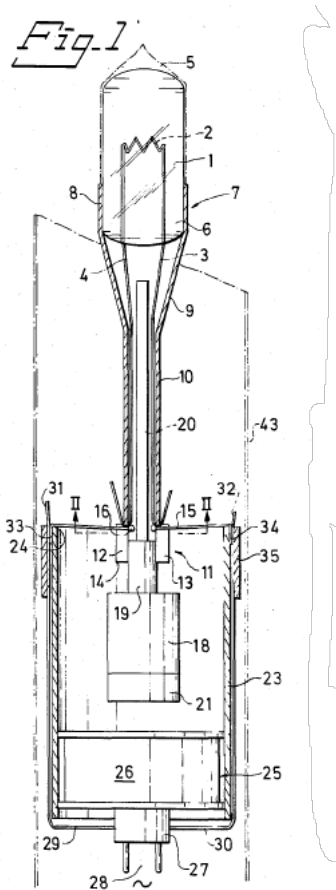

Figure 1 above illustrates an imitation candle as described in Sandell. As shown, Sandell's device includes a tube or pendulum 10 with flame-shaped bulb 1 at the top of the pendulum and permanent magnet 21 at the bottom. Ex. 1010, 2:17–20, 2:32–34, 3:19–20. The pendulum is supported by “wire-like elements” 15, which allow the pendulum to pivot. *Id.* at 3:63–64, 4:45–53. Magnetic coil 26 provides periodic pulses to create oscillation in the pendulum and better approximate the fluttering movement of a real candle. *Id.* at 1:38–42, 3:33–36, 4:14–16.

## 2. Claims 1–3

Petitioner provides a proposed mapping of Sandell to claims 1, 2, and 3 of the '166 patent. Pet. 55–58. For example, Petitioner contends Sandell discloses: a pendulum “body” with connector 11, rod 20, tube 10, and cup-shaped holder 7 (i.e., “an upper portion”), and neck 19, counterweight 18 and magnet 21 (i.e., “a lower portion”) (*id.* at 55–56 (citing, e.g., Ex. 1010, Fig. 1)); a glass envelope that may have the shape of a candle flame (i.e., “flame silhouette element”) (*id.* at 56); and holes in connector 11 which receive wire-like elements 15 to support the pendulum and allow it to pivot (*id.* at 56–57 (citing, e.g., Ex. 1010, 2:34–40, 47–51, 3:53–64)).

As discussed above, we reject Patent Owner's interpretation that chaotic pivoting requires multiple axes of movement and extreme sensitivity to initial conditions. PO Resp. 29–30. We also reject Patent Owner's reliance on an interpretation that requires showing chaotic pivoting “at the location alleged to pivot.” PO Resp. 30.

However, we have considered Patent Owner's contention that Sandell's pendulum motion is controlled, not chaotic, because of “the periodicity of the pulses being used to generate the motion.” PO Resp. 30

(citing Ex. 1010, 1:17–18, 2:11–13, 3:33–36, 4:14–46, 4:55–56; Ex. 2010 ¶¶ 76–77). Petitioner responds, citing Dr. Delson, “Sandell’s periodic pulses include a wide range of frequencies that cause the pendulum to vibrate in a way that simulates irregular movements of a ‘flickering or fluttering’ candle flame.” Pet. Reply 23 (citing Ex. 1010, 1:38–42; Ex. 1019 ¶¶ 62–64). We are not persuaded by Petitioner’s contentions.

“A claim is anticipated only if each and every element as set forth in the claim is found, either expressly or inherently described, in a single prior art reference.” *Verdegaal Bros., Inc. v. Union Oil Co. of Cal.*, 814 F.2d 628, 631 (Fed. Cir. 1987). Here, Dr. Delson explains that periodic pulses “*can* result in forced vibration of the pendulum” and “*can* result in a wide range of oscillation frequencies and amplitudes” (*see* Ex. 1019 ¶ 64 (emphasis added)), but does not contend that this is inherently so. In fact, the only evidence cited by Petitioner that vibrations or oscillations vary over time is Sandell’s statement regarding “flickering or fluttering movement of a candle flame” (Ex. 1010, 1:38–42), but this statement occurs in the background section when discussing the up and down “rocking” movement of a coil-spring based pivot means (*id.* at 1:22–34), which “*in no way corresponds to the flickering and fluttering movement of a candle flame*” (*id.* at 1:38–41 (emphasis added)). Consequently, we do not find this statement probative of Sandell necessarily disclosing pendulum movement that is not periodic.

Moreover, Petitioner does not sufficiently explain why periodic pulses do not violate the ’166 patent’s disclaimer of rhythmic or metronomic driving forces. Petitioner relies on Sandell’s statement that “pulses ‘can be supplied from any suitable known circuit’” (*see* Pet. Reply 23 n.6), but we do not view this as evidence that periodic pulses are not rhythmic or

metronomic as our construction requires. For this additional reason, we determine Petitioner has not satisfied its burden of proving anticipation against claims 1–3 by Sandell.

*J. Obviousness of Claim 7 by Sandell  
and Hall*

Petitioner argues that claim 7 of the '166 patent is unpatentable, under 35 U.S.C. § 103(a), as obvious over Sandell and Hall. *See* Pet. 58–59. We have reviewed the Petition, Patent Owner’s Response, Petitioner’s Reply, as well as the relevant evidence discussed in those papers and other record papers. Petitioner has not provided sufficient evidence to remedy the deficiency identified above with respect to Sandell. At most, Petitioner has provided evidence that such movement was a possible result of periodic pulses, but provides no evidence that a person of ordinary skill in the art would have been motivated to modify Sandell to produce pulses that were not periodic (i.e., not rhythmic or metronomic) or pulses that produced chaotic pivoting. Accordingly, we determine Petitioner has not satisfied its burden of proving obviousness of claim 7 over Sandell and Hall.

*K. Patent Owner’s Motion to Exclude*

Patent Owner “moves to exclude Exhibits 1019, 1025–1047, 1050, and 1051 submitted with Petitioner’s Reply.” Paper 38 (“Mot. Exclude”), 2.

*1. Exhibit 1019, Paragraph 52*

Patent Owner contends “[p]aragraph 52 of Exhibit 1019 includes an enlarged, redrawn, and reannotated figure from the Baba reference (Exhibit 1007). Specifically, Patent Owner contends this redrawn figure lacks authentication under FRE 901, 902, and 903,” because Dr. Delson does not indicate who redrew the figure or whether he has personal knowledge of its

origin. Mot. Exclude 4. Patent Owner also contends the figure has been redrawn and annotated to the point that it no longer represents the original Baba figure, and, therefore, is not admissible under FRE 401, 402, and 403. We are not persuaded.

Annotated Figure 1 of Dr. Delson's Declaration (Ex. 1002) is reproduced below:

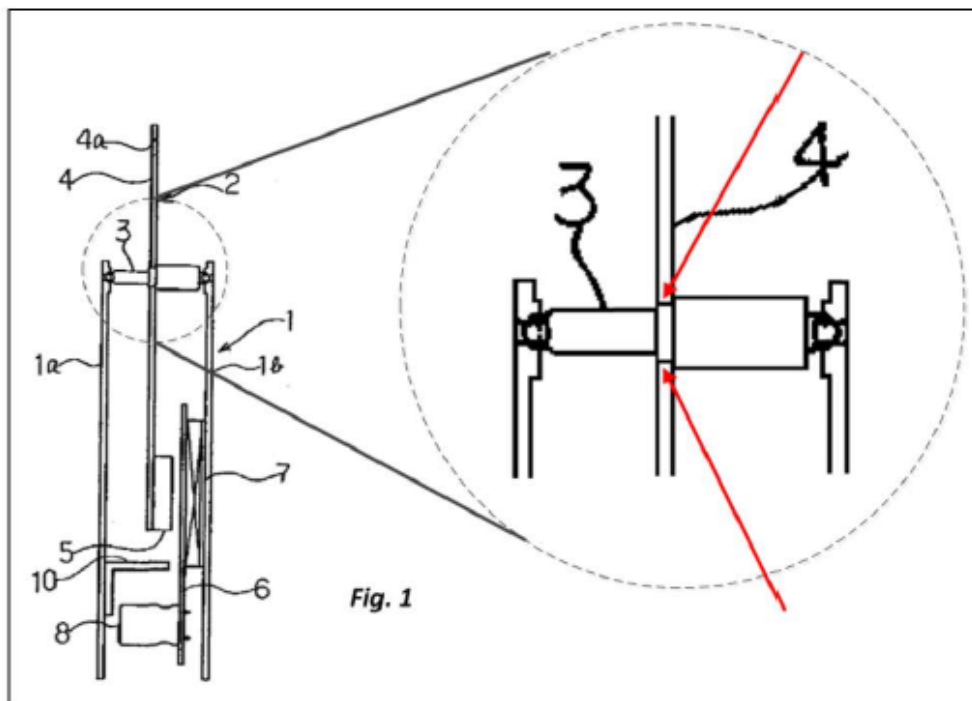

Annotated Figure 1 of Baba includes an enlarged view of the cross-section where swing arm 4 and shaft 3 intersect. *See* Ex. 1019 ¶ 52. Regardless of who created the enlarged section, Dr. Delson represents the drawing as an enlarged section of Figure 1 with arrows to point out two parallel lines on swing beam 4. *See* Ex. 1019 ¶ 52. Consistent with FRE 702, we determine that Dr. Delson may adopt such an annotated and enlarged drawing and incorporate it into his opinion. Moreover, we observe that the parallel lines are clearly visible in the unannotated drawing and, therefore, disagree that

Dr. Delson's enlarged drawing is irrelevant or misleading. *See* FRE 401–403. Accordingly, we deny Patent Owner's motion to exclude paragraph 52 of Exhibit 1019.

2. Remaining Exhibits

Except for paragraph 52 in Exhibit 1019, we have not relied on the exhibits Patent Owner seeks to exclude. Patent Owner also states that:

It is not enough for the Board to find that this motion is moot if the Board does not rely on the inadmissible items of evidence in reaching its Final Written Decision. If the items of evidence are allowed to remain in the record, Liown could continue to rely on them on appeal to the Federal Circuit, where Luminara could unfairly be forced to face them again.

*Id.* at 3.

We have *not* relied on Exhibits 1025–1047, 1050, or 1051 in this Decision. We also have not relied on paragraph 53 or 59 of Exhibit 1019, which are the only other paragraphs (i.e., other than 52) of that exhibit Patent Owner contends should be excluded. We have considered Patent Owner's suggestion that we rule on its objections regardless of that fact.

For exhibits not relied on, the Board's well-established practice is to dismiss motions to exclude such evidence as moot. *See, e.g., Apple, Inc. v. VirnetX, Inc.*, Case IPR2015-00812, slip op. at 40–41 (PTAB Aug. 30, 2016) (Paper 43); *Array BioPharma, Inc. v. Takeda Pharm. Co. Ltd.*, Case IPR2015-00754, slip op. at 36, 46 (PTAB Aug. 12, 2016) (Paper 61); *Daicel Corp. v. Celanese Int'l Corp.*, Case IPR2015-00171, slip op. at 62 (PTAB June 23, 2016) (Paper 86); *Bank of Am., N.A., v. Intellectual Ventures I, LLC*, Case CBM2014-00029, slip op. at 30 (PTAB May 19, 2015) (Paper 38); *Yamaha Corp. of Am. v. Black Hills Media, LLC*, Case IPR2013-00597, slip op. at 29–30 (PTAB Mar. 18, 2015) (Paper 46); *Nichia Corp. v. Emcore*

*Corp.*, Case IPR2012-00005, slip op. at 57–58 (PTAB Feb. 11, 2014) (Paper 68).

In this case, Patent Owner has moved to exclude nearly 30 exhibits on numerous grounds. An advisory opinion on their admissibility when we have not considered them would be improper. Moreover, Patent Owner has not cited any authority for its suggestion that it is “not enough” for the Board to act in accordance with its established procedure. Accordingly, we decline Patent Owner’s suggestion, and *dismiss* its motion to exclude as *moot*.

### III. CONCLUSION

For the foregoing reasons, Petitioner has demonstrated by a preponderance of the evidence that claims 1 and 13 are anticipated by Schnuckle ’455; claims 2–4, 14, 20, and 22 are unpatentable as directed to obvious subject matter over Schnuckle ’455; claims 18, 19, and claim 26 are unpatentable as directed to obvious subject matter over Schnuckle ’455 and Helmer; claim 7 is unpatentable as directed to obvious subject matter over Schnuckle ’455 and Cornell; claims 1–4, 13, 14, 18, 20, and 22 are unpatentable as directed to obvious subject matter over Wiklund and Baba; and claims 19 and 26 are unpatentable as directed to obvious subject matter over Wiklund, Baba, and Meeker. However, Petitioner has not demonstrated by a preponderance of the evidence that claims 1–3 are anticipated by Sandell or that claim 7 is directed to obvious subject matter over Sandell and Hall.



#### IV. ORDER

In consideration of the foregoing, it is hereby:

ORDERED that claims 1–4, 7, 13, 14, 18–20, 22, and 26 of the '166 patent have been shown to be unpatentable;

FURTHER ORDERED that, as to Exhibit 1019, paragraph 52, Patent Owner's Motion to Exclude is denied and, as to the remaining exhibits, Patent Owner's Motion to Exclude is dismissed as moot; and

FURTHER ORDERED that, because this is a Final Written Decision, parties to the proceeding seeking judicial review of the decision must comply with the notice and service requirements of 37 C.F.R. § 90.2.

IPR2015-01658  
Patent 8,696,166 B2

PETITIONER:

Thomas N. Millikan  
Bing Ai  
Joseph P. Reid  
Babak Tehranchi  
Patrick McKeever  
PERKINS COIE LLP,  
luminarapatentiprservice@perkinscoie.com  
TMillikan@perkinscoie.com  
Ai-ptab@perkinscoie.com  
JReid@perkinscoie.com  
BTehranchi@perkinscoie.com  
pmckeever@perkinscoie.com

PATENT OWNER:

David K.S. Cornwell  
Jon E. Wright  
Richard D. Collier III  
STERNE, KESSLER, GOLDSTEIN & FOX PLLC  
davidc-PTAB@skgf.com  
jwright-PTAB@skgf.com  
rcoller-PTAB@skgf.com

Ryan S. Dean  
John van Loben Sels  
FISH & TSANG, LLP  
rdean@fishiplaw.com  
jvanlobensels@fishiplaw.com

Courtland C. Merrill  
Daniel R. Hall  
ANTHONY OSTLUND BAER & LOUWAGIE P.A.  
cmerrill@anthonyostlund.com  
dhall@anthonyostlund.com