

UNITED STATES PATENT AND TRADEMARK OFFICE

BEFORE THE PATENT TRIAL AND APPEAL BOARD

POWER INTEGRATIONS, INC.,
Petitioner,

v.

SEMICONDUCTOR COMPONENTS INDUSTRIES, LLC,
Patent Owner.

Case IPR2017-01944
Patent RE41,908 E

Before BRYAN F. MOORE., JAMES B. ARPIN, and KAMRAN JIVANI,
Administrative Patent Judges.

ARPIN, *Administrative Patent Judge.*

DECISION

Denying Institution of Inter Partes Review
35 U.S.C. § 314(a) and 37 C.F.R. § 42.108

I. INTRODUCTION

A. Background

Power Integrations, Inc. (“Petitioner”) filed a Petition (Paper 2, “Pet.”) to institute an *inter partes* review of claims 21–22, 24–26, 28–31, 33–39, 41–44, 46–48, and 50–53 (the “challenged claims”) of U.S. Patent No. RE41,908 E to Hall *et al.* (Ex. 1001, “the ’908 patent”), pursuant to 35 U.S.C. §§ 311–319. Pet. 4. Semiconductor Components Industries, LLC (“Patent Owner”) filed a Preliminary Response (Paper 6, “Prelim. Resp.”). We have authority under 35 U.S.C. § 314, which provides that an *inter partes* review may not be instituted “unless . . . there is a reasonable likelihood that the petitioner would prevail with respect to at least 1 of the claims challenged in the petition.” 35 U.S.C. § 314(a).

Petitioner relies upon the following declaration and reference in support of its ground for challenging claims 21–22, 24–26, 28–31, 33–39, 41–44, 46–48, and 50–53 of the ’908 patent.

Exhibit	Declaration and Reference
1003	Declaration of Tamas Szepesi, Ph.D.
1004 ¹	Robert A. Mammano, <i>Voltage-Mode Control Revisited – A New High-Frequency Controller Features Efficient Off-Line Performance</i> , 1993 HIGH FREQUENCY POWER CONVERSION CONFERENCE 40 (May 23–27, 1993) (“Mammano”)

Pet. ii.

Petitioner asserts that the challenged claims are unpatentable on the following ground (Pet. 4, 13–51):

¹ The page numbers for Ex. 1004 are those numbers appearing at the bottom of each page, which Petitioner added.

Claims	Ground	Reference
21–22, 24–26, 28–31, 33–39, 41–44, 46–48, and 50–53	35 U.S.C. § 102(b)	Mammano

For the reasons set forth below, we determine that, on this record, Petitioner fails to demonstrate a reasonable likelihood of prevailing in showing the unpatentability of any of the challenged claims. Accordingly, we *deny* institution of *inter partes* review as to any of the challenged claims of the '908 patent.

B. Related Proceedings

Petitioner was sued for infringement of the '908 patent by Patent Owner: *On Semiconductor Corp. v. Power Integrations, Inc.*, Case No. 2:16-cv-02720 (D. Az.), on August 11, 2016. Pet. 2. That case was subsequently transferred to a U.S. district court in California and consolidated with another case brought by Petitioner. The case caption for the consolidated case is *Power Integrations, Inc. v. On Semiconductor Corp. et al.*, 5:16-cv-06371-BLF, 5:17-cv-03189-BLF (N.D. Cal.). *Id.* Petitioner also has filed petitions to review several of Patent Owner's other patents – U.S. Patent Nos. RE45,862 E (IPR2017-01903); 6,333,624 B1 (IPR2017-01907); and RE39,931 E (IPR2017-01904 and IPR2017-01975). *See id.*

C. The '908 Patent

The '908 patent, entitled “Power Conversion Integrated Circuit and Method for Programming,” relates generally to integrated circuits and more particularly to power conversion integrated circuits. Ex. 1001, [54], 1:18–20. “A switched-mode power supply is an electronic power supply that incorporates a switching regulator to efficiently convert electrical power. [In

particular, a switched mode power supplies convert an unregulated input power source (AC or DC) into a regulated DC output to power electronic devices such as computer equipment, TVs, and the like.” Pet. 4–5 (citing Ex. 1003 ¶¶ 33–40). Therefore, the Specification of the ’908 patent teaches power conversion integrated circuits that operate with different power supplies and minimize the number of external components required for controlling the power supply on/off switch circuitry. Ex. 1001, 1:42–47.

Figure 1 of the ’908 patent, as annotated by Petitioner, is reproduced below:

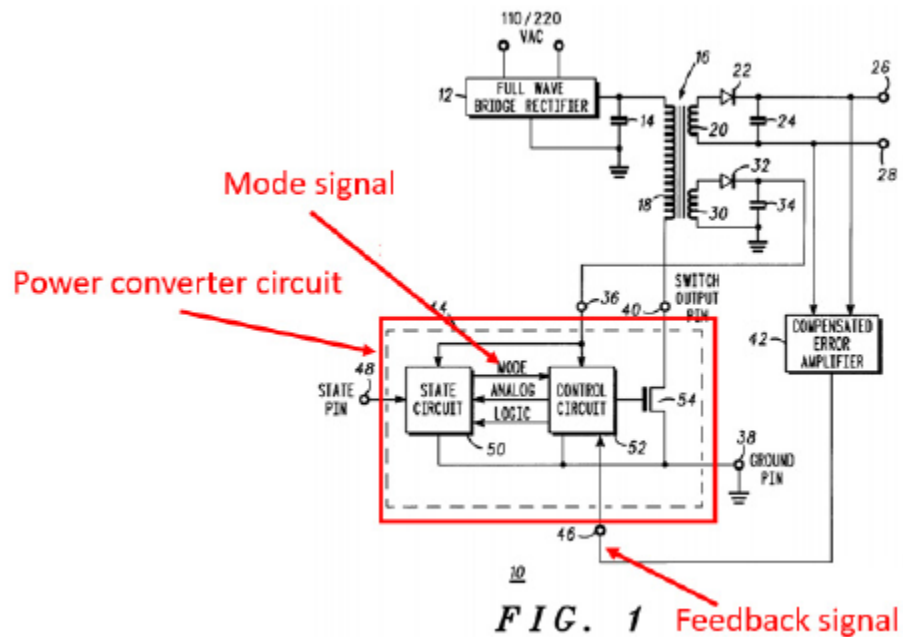

Figure 1 depicts power supply 10 using integrated power converter circuit 44. Power supply 10 is controlled by power converter circuit 44, which includes five pins: bias pin 36, ground pin 38, feedback pin 46, state pin 48, and switch output pin 40. Ex. 1001, 2:44–48.

The feedback signal is used by control circuit 52 for altering the pulse width of the signal that is supplied to the control terminal of transistor 54. Thus, compensated error amplifier 42 alters the

pulse width of the output signal at switch output pin 40 in accordance with the voltage developed across terminals 26 and 28. The variable pulse width modifies the current in transformer 16, thereby regulating the voltage of the DC output signal. In addition, the bias voltage developed at bias pin 36 from secondary winding 30 can be used as the operating supply voltage of state circuit 50 and control circuit 52. The bias voltage developed at bias pin 36 can alternately be derived from secondary winding 20. It should be noted that compensated error amplifier 42 can be replaced with a high gain comparator, or the like.

Id. at 3:16–29. Thus, the feedback signal alters the pulse width of the control signal driving transistor 54 and, thus, regulates the output voltage of power supply 10. *Id.* “The value at the state pin 48 is used by the state circuit to generate a ‘mode’ signal, which is output to, and used by, the control circuit 52 to control the on/off states of the power supply.” Pet. 7–8; *see* Ex. 1001, 2:58–60.

Figure 2 of the '908 patent, as annotated by Petitioner, is reproduced below:

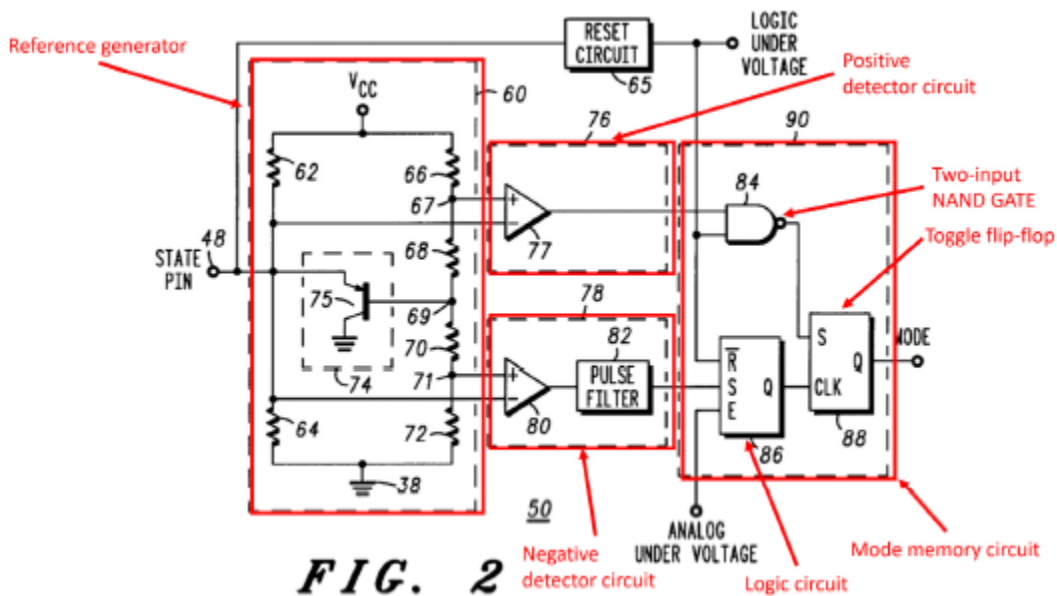

Figure 2 depicts an embodiment of the state circuit portion of power converter circuit 44. “The state circuit includes reference generator 60, which is a resistance network that creates threshold voltages for the comparators of the positive detector circuit 76 and negative detector circuit 78.” Pet. 9 (citing Ex. 1001, 3:66–4:2). The Specification describes that the resistance network may generate reference voltages of 2.9 volts (at node 67) for positive detector circuit 76 and 1.1 volts (at node 71) for negative detector circuit 78. Ex. 1001, 3:66–4:17. “An output of comparator 77 is connected to an output of positive detector circuit 76. Negative detector circuit 78 includes a comparator 80 connected to a pulse filter 82.” Ex. 1001, 4:23–26.

Mode memory circuit 90 includes two-input NAND gate 84, logic circuit 86, and positive edge triggered toggle flip-flop 88. *Id.* at 4:36–38. NAND gate 84 has one input connected to the output of positive detector circuit 76 and the other input coupled to receive the signal entitled “LOGIC UNDER-VOLTAGE.” *Id.* at 4:39–42. As voltage V_{cc} increases from a starting voltage of zero, the signal LOGIC UNDER-VOLTAGE has an initial logic zero value that increases to logic level one at a predetermined V_{cc} voltage. *Id.* at 4:42–46. By increasing this signal to logic level one, the V_{cc} voltage is sufficient to operate the logic circuitry. *Id.* at 4:45–47. Similarly, the “ANALOG UNDER-VOLTAGE” ensures that the transistors in the circuit have a sufficient supply voltage to operate. *Id.* at 4:53–61. “The output of the mode memory circuit 90, ‘MODE,’ is input to control circuit 52, which uses this signal to control whether the power supply is turned on or off.” Pet. 10 (citing Ex. 1001, 5:10–13, 5:51–52).

D. Illustrative Claim

Petitioner challenges claims 21–22, 24–26, 28–31, 33–39, 41–44, 46–48, and 50–53 of the '908 patent. Claims 21, 26, 28, 34, 41, 46, and 50 are independent. Claims 22 and 24 depend from claim 21, claim 25 depends from claim 26, claims 29–31 and 33 depend from claim 28, claims 35–39 depend from claim 34, claims 42–44 depend from claim 41, claims 47 and 48 depend from claim 46, and claims 51–53 depend from claim 50.

Claim 21 is directed to a power supply regulating circuit. Claim 21 is illustrative and is reproduced below:

21. A power supply regulator circuit, comprising:

a terminal adapted for receiving a mode control signal having a latchable state, wherein the latchable state of the mode control signal controls an operational on-state or a non-operational off-state of the power supply regulator circuit; and

a pulse width modulated (PWM) regulator circuit having a first input coupled for receiving a feedback signal, and an output for providing a PWM switching signal in response to the feedback signal, the PWM regulator circuit including,

(a) a first comparator having an input coupled for receiving the mode control signal, and an output having first or second states depending on a comparison between the mode control signal and a first reference value,

(b) a second comparator having an input coupled for receiving the mode control signal, and an output having first or second states depending on a comparison between the mode control signal and a second reference value different from the first reference value, and

(c) a logic circuit having a first input coupled to the output of the first comparator, a second input coupled to the output of the second comparator, the logic circuit decoding the outputs of the first and second comparators and setting the PWM regulator circuit to the non-operational off-state

to conserve energy for an extended period of time as determined by the latchable state of the mode control signal, wherein the regulator circuit is provided in a monolithic integrated circuit package and the terminal is coupled to a pin of the monolithic integrated circuit package.

Ex. 1001, 11:20–52 (claim 21).

E. Person of Ordinary Skill in the Art

Petitioner asserts that the earliest filing date for the '908 patent is June 4, 1997. Pet. 13; *see* Ex. 1001, [64]. Petitioner argues that, as of that date, a person of ordinary skill in the art “would have the equivalent of a Bachelor’s degree or higher in electrical engineering with at least 3 years working experience in the design of electronic circuits, would be familiar with switching voltage regulator circuits and with the operation, design and fabrication of integrated circuits related to switching voltage regulators.” Pet. 12 (citing Ex. 1003 ¶ 32). At this time, Patent Owner does not propose an alternative assessment of a person of ordinary skill in the art. For purposes of this Decision, and to the extent necessary, we adopt Petitioner’s assessment.

F. Claim Construction

The '908 patent allegedly expired on June 4, 2017. Pet. 13; *see* Ex. 1001, [64]. Claims of an *expired* patent are given their ordinary and customary meaning in accordance with *Phillips v. AWH Corp.*, 415 F.3d 1303 (Fed. Cir. 2005) (en banc). *See In re Rambus Inc.*, 694 F.3d 42, 46 (Fed. Cir. 2012); *see also Black & Decker, Inc. v. Positec USA, Inc.*, 646 F. App’x. 1019, 1024 (non-precedential) (applying the *Phillips* standard to construe the claims of an expired patent in an *inter partes* review).

Neither Petitioner nor Patent Owner, however, proposes constructions for any claim terms. Pet. 13; Prelim. Resp. ii. We do not construe any term at this time because no term needs to be construed expressly for purposes of this Decision.

II. ANALYSIS

A. Overview

“A petitioner in an inter partes review may request to cancel as unpatentable 1 or more claims of a patent only on a ground that could be raised under section 102 or 103 and *only on the basis of prior art consisting of patents or printed publications.*” 35 U.S.C. § 311(b) (emphasis added); *see* 37 C.F.R. § 42.104(b)(2). “A claim is anticipated only if each and every element as set forth in the claim is found, either expressly or inherently described, in a single prior art reference.” *Verdegaal Bros. v. Union Oil Co.*, 814 F.2d 628, 631 (Fed. Cir. 1987).

Petitioner argues that each of claims 21–22, 24–26, 28–31, 33–39, 41–44, 46–48, and 50–53 of the ’908 patent is anticipated by Mammano. *See supra* Section I.A.

[W]hether information is printed, handwritten, or on microfilm or a magnetic disc or tape, etc., *the one who wishes to characterize the information, in whatever form it may be, as a “printed publication” . . . should produce sufficient proof of its dissemination or that it has otherwise been available and accessible to persons concerned with the art to which the document relates and thus most likely to avail themselves of its contents.*

In re Wyer, 655 F.2d 221, 227 (CCPA 1981) (emphasis added). Thus, Petitioner has the burden to establish in its Petition a reasonable likelihood of success, including, among other things, making a threshold showing that

Mammano is a “printed publication” within the meaning of 35 U.S.C. §§ 102(b) and 311(b). 35 U.S.C. § 314(a); *see* 37 C.F.R. § 42.108(c); *Apple, Inc. v. DSS Tech. Mgmt., Inc.*, Case IPR2015-00369, slip op. at 4–5, 9–11 (PTAB Aug. 12, 2015) (Paper 14). For the reasons set forth below and on this record, Petitioner does not satisfy this burden.

B. Printed Publications

Petitioner argues that Mammano is a printed publication and that it may properly assert this reference as a basis for the ground of unpatentability in its Petition because Mammano allegedly was published in May 1993 more than one year before the earliest filing date (June 4, 1997) of the '908 patent. Pet. 4; *see* 35 U.S.C. § 312(a)(3)(A); 37 C.F.R. § 42.104(b)(2). Patent Owner disagrees, and contends that Petitioner fails to demonstrate that Mammano is a printed publication. Prelim. Resp. 1–8.

“Public accessibility” is the touchstone in determining whether a reference is a “printed publication.” *In re Hall*, 781 F.2d 897, 898–99 (Fed. Cir. 1986); *see, e.g., L-3 Commc’n. Holdings, Inc. v. Power Survey, LLC*, Case IPR2014-00832, slip op. at 11–12 (PTAB Nov. 14, 2014) (Paper 9) (applied reference not shown to be publicly accessible); *C&D Zodiac, Inc. v. B/E Aerospace, Inc.*, Case IPR2014-00727, slip op. at 20–22 (PTAB Oct. 29, 2014) (Paper 15) (applied reference shown to be publicly accessible). Although some cases, such as *In re Cronyn*, 890 F.2d 1158, 1160 (Fed. Cir. 1989), refer simply to “the public interested in the art,” the majority of cases appear to define the standard as accessibility to persons interested and ordinarily skilled in the art. *See Bruckelmyer v. Ground Heaters, Inc.*, 445 F.3d 1374, 1379 (Fed. Cir. 2006) (clarifying that in *Cronyn*, the Court determined that three student theses were not publicly accessible and “[t]he

significance of whether these theses were meaningfully catalogued or indexed was whether *one skilled in the art* could locate them” (emphasis added)).²

Consequently, “[a] reference will be considered publicly accessible if it was ‘disseminated or otherwise made available to the extent that persons interested and ordinarily skilled in the subject matter or art exercising reasonable diligence, can locate it.’” *Blue Calypso, LLC v. Groupon, Inc.*, 815 F.3d 1331, 1348 (Fed. Cir. 2016) (quoting *Kyocera Wireless Corp. v. Int’l Trade Comm’n*, 545 F.3d 1340, 1350 (Fed. Cir. 2008) (quoting *SRI Int’l, Inc. v. Internet Sec. Sys., Inc.*, 511 F.3d 1186, 1194 (Fed. Cir. 2008))). The status of a reference as a printed publication is a legal conclusion “based on underlying factual determinations.” *Blue Calypso*, 815 F.3d at 1348 (citing *In re Lister*, 583 F.3d 1307, 1311 (Fed. Cir. 2009)). As noted above, Petitioner argues that Mammano qualifies as prior art solely because it allegedly was published more than one year prior to the earliest filing date of the ’908 patent. Pet. 4.

When determining whether the petitioner’s arguments and evidence are sufficient to support institution of *inter partes* review, we note that:

The reasonable likelihood standard for instituting *inter partes* review is . . . not a *lower* standard of proof than a preponderance of the evidence, but instead asks whether the same preponderance standard is reasonably likely to be met *at a later time*. We must assess the persuasiveness of the petitioner’s evidence while “recognizing that [we are] doing so without all evidence that may come out at trial.” As such, we have required only a “threshold showing” of public availability in order to

² Petitioner does not argue that Mammano was catalogued or indexed, such that persons skilled in the relevant art could locate it. Pet. 4; *see* Prelim. Resp. 2.

institute trial.

ServiceNow, Inc. v. Hewlett-Packard Co., Case IPR2015-00707, slip op. at 2 (PTAB August 26, 2015) (Paper 12) (Crumbley, APJ, dissenting) (citations omitted). For the reasons set forth below, we determine that Petitioner’s arguments and evidence with respect to the status of Mammano as a printed publication are unpersuasive and, therefore, that Petitioner is not reasonably likely to succeed in establishing the unpatentability of any challenged claim.³

Petitioner asserts that “Mammano was *published* in May 1993, more than one year prior to the ’908 patent’s earliest priority date, and thus is prior art under 35 U.S.C. § 102(b).” Pet. 4 (emphasis added, citing Ex. 1003 ¶ 58). This single sentence is the sum total of Petitioner’s argument in the Petition for the public accessibility of Mammano. *See* Prelim. Resp. 8. Petitioner’s naked assertion that Mammano was *published*, and, therefore, publicly accessible, is not supported by the record, which fails to identify the circumstances and manner in which the reference was disseminated or in which persons interested and ordinarily skilled in the subject matter could locate the reference. *Cisco Systems, Inc. v. Constellation Techs., LLC*, Case IPR2014-01085, slip op. at 7–9 (PTAB Jan. 9, 2015) (Paper 11) (noting “naked assertion,” unsupported by record, that reference was published).

On its face, Mammano purports to be an article prepared by a

³ Although a petitioner may have had later opportunities to supplement the record, this is no guarantee that deficiencies existing in the record at institution will be cured later. *See GoPro, Inc. v. Contour IP Holding LLC*, Case IPR2015-01078, slip op. at 19–28 (PTAB Oct. 26, 2016) (Paper 54); *GoPro, Inc. v. Contour IP Holding LLC*, Case IPR2015-01078, slip op. at 2–10 (PTAB Feb. 16, 2017) (Paper 59).

presenter at the High Frequency Power Conversion Conference, held in Vienna, VA, on May 23–27, 1993. Ex. 1004, 1, 2. This article was bound together with articles prepared by other presenters as a hard cover book and was apparently intended to be distributed to attendees at the conference. Ex. 1004, 1 (“This Book is the Property of:”), 2 (“Technical Papers and Authors”); *see* Ex. 1003 ¶ 58 (“[Copies of the Technical Papers were] provided to the conference attendees as a hard cover book.”).

Although Petitioner does not cite to any portion of Mammano in support of its argument, Petitioner does cite to testimony by Petitioner’s declarant, Dr. Szepesi, that he received the copy of Mammano that is relied upon in the Petition. Specifically, Dr. Szepesi testifies that:

Mammano was presented at the Eighth International High Frequency Power Conversion Conference, which took place from May 23–27, 1993, in Vienna, Virginia. I personally attended the conference and received a copy of Mammano as part of the Technical Papers of the Conference (which was provided to the conference attendees as a hard cover book). The Technical Papers of the Conference, including Mammano, was freely distributed to all attendees. The copy of Mammano attached to the petition as Exhibit 1004 in this case is a photocopy of the original document from the Technical Papers of the Conference that I received at the conference and that has been in my possession since the conference.

Ex. 1003 ¶ 58. Petitioner maintains that Dr. Szepesi’s testimony regarding the circumstances surrounding Dr. Szepesi’s receipt and possession of Mammano serve to authenticate this exhibit. Ex. 1019, 11:13–16. Petitioner further argues that the nature of the reference, namely, that it is a conference paper; “the kind of agenda for the conference”; and Petitioner’s declarant’s attendance at the conference and retention of this copy of Mammano are evidence of the public accessibility of Mammano. *Id.* at 8:15–9:5.

We have considered Petitioner’s arguments, Dr. Szepesi’s testimony, and Mammano itself, and we do not find that Petitioner presents persuasive evidence of Mammano’s public accessibility. Referring to Exhibit 1004’s cover page, the cover page indicates that it is the “Technical Papers of the Eighth International High Frequency Power Conversion 1993 Conference” and that the conference occurred on May 23–27, 1993 in Vienna, VA.

Ex. 1004, 1. Given Dr. Szepesi’s testimony (Ex. 1003 ¶ 58), we accept that Mammano is a paper presented at the conference and that the conference occurred on the dates set forth.

Nevertheless, initially, we note that neither Petitioner nor Dr. Szepesi provides any evidence concerning how the conference was publicized and promoted and to whom. Specifically, Petitioner argues that

conference papers and conference agendas to conferences *that were open to anybody who is in the art suffice* and the indicia from the document itself — for example, all of the authors who were present at the conference who you can see in the table of contents, those authors necessarily would have been at the conference — and so the indicia from the document itself provides evidence that there was more — this wasn’t just one guy at a conference, which is kind of the allegation that is being made here. These are industry leaders and professors presenting at a conference, and at least the other presenters at the conference would have been present at the conference.

Ex. 1019, 9:16–10:4 (emphasis added). Petitioner, however, leaves it to us to suppose the facts that would support these arguments. Petitioner does not provide evidence from which we may determine that this conference was publicized or promoted to persons skilled in the art.

In *Mass. Inst. of Tech. v. AB Fortia*, 774 F.2d 1104, 1108–09 (Fed. Cir. 1985), our reviewing court affirmed the tribunal’s conclusion that a research paper was prior art based on evidence that the paper “was orally

presented by Dr. Levine of the [Massachusetts Institute of Technology] group to the First International Cell Culture Congress in Birmingham, Alabama, September 21–25, 1975,” which “was attended by 50 to 500 cell culturists,” and that “copies were distributed on request, without any restrictions, to as many as six persons, more than one year before the filing date of the ‘534 and ‘654 patents.” However, without sufficient evidence regarding the publication of and attendance at the conference, public accessibility cannot be shown. *See SRI Int’l*, 511 F.3d at 1197 (prior art not shown to be publicly accessible when it is “analogous to placing posters at an unpublicized conference with no attendees,” prior art must be “publicized or placed in front of the interested public”).

Second, apart from the list of authors provided in Exhibit 1004, Petitioner does not provide evidence regarding who presented at the conference and who attended the conference and whether those persons satisfied Petitioner’s assessment of a person of ordinary skill in the art (*see supra* Section I.E.).⁴ *See* Prelim. Resp. 2–3. As noted above, Petitioner asserts that the presenters were “industry leaders and professors” and that at least the listed presenters would have been present at the conference. Ex. 1019, 10:1–4; *see* Ex. 1004, 2. Petitioner does not argue that Dr. Szepesi was a person of ordinary skill in the art at the time of the conference, and Dr. Szepesi does not assert that he was a person of ordinary skill in the art as of that date. *See* Ex. 1003 ¶¶ 9–19; Ex. 1007. In particular, Dr. Szepesi does not testify that he had experience in the fabrication of integrated circuits related to switching voltage regulators at the time that he

⁴ For example, apart from his title and the name of his employer, we are told nothing about Mr. Mammano’s education or qualifications.

attended the High Frequency Power Conversion Conference, May 23–27, 1993. Ex. 1003 ¶¶ 13, 14; Ex. 1004, 1. Limited distribution, however, even to those skilled in the art, may not amount to “publication” under the statute unless the material is otherwise so situated that “any one who chooses may avail himself of the information it contains.” *In re Bayer*, 568 F.2d 1357, 1360, 1362 (CCPA 1978) (quoting 1 W. Robinson, *The Law of Patents* 327 at 448 (1890); holding that the distribution of alleged prior art to three members of a graduate committee, concededly members of the “interested public,” for purposes of assessing appellant’s entitlement to a degree did not, as a matter of law, “transmute[] . . . [the thesis] into a patent-defeating publication.”)

As noted above, Petitioner asserts, without sufficient factual support, that the presenters were “industry leaders and professors” and that at least the listed presenters would have been present at the conference. Ex. 1019, 101–4; *see* Ex. 1004, 2. While the Table of Contents is some evidence of who attended the conference, we note that many of the papers list multiple authors. Ex. 1004, 3. We cannot determine who attended the conference and who presented the papers based solely on the listing in the Table of Contents. *See* Prelim. Resp. 4–5

Here, Petitioner does not provide sufficient evidence that any person attending the conference satisfied Petitioner’s assessment of a person of ordinary skill in the art. *See id.*; *cf. LG Electronics, Inc. v. Core Wireless Licensing S.A.R.L.*, Case IPR2015-01986, slip op. at 29 (PTAB Mar. 16, 2017) (Paper 34) (“As explained above, in this proceeding, the papers in question were handed out without restriction *to at least dozens of skilled artisans*, with more being alerted, by email, to the posting of the documents

on 3GPP's server.” (emphasis added)); *Suffolk Techs., LLC v. AOL Inc.*, 752 F.3d 1358, 1365 (Fed. Cir. 2014) (relying on “at least six responses” to a reference posted to an online newsgroup *including persons of ordinary skill in the art* and noting that “[m]any more people may have viewed the post”); *In re Klopfenstein*, 380 F.3d 1345, 1350 (Fed. Cir. 2004) (“In this case, the Liu reference was displayed to the public approximately two years before the '950 application filing date. The reference was shown to a wide variety of viewers, *a large subsection of whom possessed ordinary skill in the art of cereal chemistry and agriculture.*” (emphasis added)). As noted above, Petitioner does not argue that Dr. Szepesi, the one person whom we know to have attended the conference and received a copy of the technical papers book, was a person of ordinary skill in the art at the time of the conference, and, on this record, we cannot discern whether Dr. Szepesi met Petitioner's assessment of a person of ordinary skill in the art at the time of the conference. *See supra* Section I.E.

Third, neither Petitioner nor Dr. Szepesi provides evidence of the conditions, if any, under which the technical papers were distributed to the conference attendees. Petitioner provides no evidence regarding whether the technical papers book was provided to conference attendees with or without restriction. The cover page of the Exhibit 1004 includes the statement: “This Book is the Property of:”. Ex. 1004, 2. On Dr. Szepesi's copy of the technical papers book, the line following this statement is blank. Although this statement may suggest that the book is the property of the attendee to whom it was given and that the attendee may do with it as he or she pleases, Petitioner does not make this argument, and we decline to draw that inference without more evidentiary basis.

During a conference call on January 9, 2018, Petitioner requested authorization to file a reply to Patent Owner's Preliminary Response and to respond to Patent Owner's contentions regarding the public accessibility of Mammano. Ex. 1019, 5:20–6:2. Nevertheless, Petitioner acknowledged that the panel was capable of assessing the requirements of the law and the evidence of record (*see id.* at 7:17–8:4) and that Petitioner did not intend to submit further evidence regarding public accessibility (*see id.* at 10:13–12:3). In particular, Petitioner stated that it did not wish to submit a further declaration from Dr. Szepesi, who was not only an attendee, but appears to have been a presenter (*see* Ex. 1004, 3 (Session 2.9)), concerning the public accessibility of the technical papers book. Ex. 1019, 11:11–13. Therefore, we denied authorization for a reply. *Id.* at 19:20–21:11.

Consequently, on this record, we are not persuaded that Petitioner makes the necessary threshold showing that Mammano (Ex. 1004) was a printed publication more than one year before the earliest filing date (June 4, 1997) of the '908 patent.

III. CONCLUSION

Petitioner fails to demonstrate that there is a reasonable likelihood of prevailing in its challenge to the patentability of any of claims 21–22, 24–26, 28–31, 33–39, 41–44, 46–48, and 50–53 of the '908 patent. Consequently, the Petition is *denied* as to the asserted ground.

IV. ORDER

For the reasons given, it is
ORDERED that the Petition is *denied*, and no *inter partes* review is instituted.

IPR2017-01944
Patent RE41,908 E

PETITIONER:

John C. Phillips
Neil A. Warren
FISH & RICHARDSON P.C.
phillips@fr.com
warren@fr.com

PATENT OWNER:

Roger Fulghum.
Brian W. Oaks
Brett J. Thompsen
Nick Schuneman
Jennifer Nall
BAKER BOTTS L.L.P.
roger.fulghum@bakerbotts.com
brian.oaks@bakerbotts.com
brett.thompsen@bakerbotts.com
nick.schuneman@bakerbotts.com
jennifer.nall@bakerbotts.com