

UNITED STATES PATENT AND TRADEMARK OFFICE

BEFORE THE PATENT TRIAL AND APPEAL BOARD

KAMSTRUP A/S,
Petitioner,

v.

APATOR MIITORS APS,
Patent Owner.

Case IPR2015-01403
Patent 8,893,559 B2

Before JAMESON LEE, MATTHEW R. CLEMENTS, and
JOHN F. HORVATH, *Administrative Patent Judges*.

HORVATH, *Administrative Patent Judge*.

FINAL WRITTEN DECISION
35 U.S.C. § 318(a) and 37 C.F.R. § 42.73

I. INTRODUCTION

A. Background

Kamstrup A/S (“Petitioner”) filed a Petition (Paper 1, “Pet.”) to institute *inter partes* review of claims 1–13 of U.S. Patent No. 8,893,559 B2 (Ex. 1001, “the ’559 patent”). Apator Miitors Aps (“Patent Owner”) filed a Preliminary Response (Paper 6, “Prelim. Resp.”). Upon consideration of the Petition and Preliminary Response, we instituted an *inter partes* review to determine the patentability of claims 1–13. Paper 7 (“Dec. Inst.”).

Subsequent to institution, Patent Owner filed a Response (Paper 15, “PO Resp.”), and Petitioner filed a Reply (Paper 19, “Pet. Reply”). An oral hearing was held on September 9, 2016, and a transcript of the hearing is included in the record. Paper 27 (“Tr.”).

This is a Final Written Decision under 35 U.S.C. § 318(a) and 37 C.F.R. § 42.73. For the reasons set forth below, Petitioner has shown by a preponderance of the evidence that claims 1–13 of the ’559 patent are unpatentable.

B. Related Matters

Neither Petitioner nor Patent Owner indicates the existence of any matter that would affect, or be affected by, a decision in this proceeding. Pet. 1; Paper 5, 3.

C. Prior Art Relied Upon

Reference		Effective Date ¹	Exhibit
Walker	US 1,473,751	Nov. 13, 1923	Ex. 1004
Yamamoto	US 3,237,453	Mar. 1, 1966	Ex. 1005
Drachmann '311	EP 1 983 311 A2	Oct. 22, 2008	Ex. 1006
Drachmann '250 ²	EP 2 083 250 A1	July 29, 2009	Ex. 1007
Körner ³	EP 1 798 528 A1	June 20, 2007	Ex. 1011
Marsh	EP 0 813 041 A1	Dec. 17, 1997	Ex. 1013
Buckberry	WO 2008/053193 A1	May 8, 2008	Ex. 1014
Rhodes	WO 2007/020375 A1	Feb. 22, 2007	Ex. 1015
Nielsen	US 2012/0006127 A1	Mar. 25, 2010 ⁴	Ex. 1016

¹ Unless otherwise indicated, the effective date is the issue date of any issued patent, and the publication date of any published patent application.

² Drachmann '250 is a published European Patent Application, listing Jens Drachmann, Anders Skallebæk, and Peter Schmidt Laursen as inventors. Ex. 1007, (72). It is a foreign printed publication, by others, before the invention by the applicant of the '559 patent (Jens Drachmann), and is prior art to the '559 patent under 35 U.S.C. § 102(a).

³ In this decision, all references to Körner are made to the certified English translation thereof, designated Exhibit 1012.

⁴ Nielsen is a publication of a US national phase application filed on September 21, 2011, and claiming priority to the filing date of PCT application PCT/DK2010/050066. Ex. 1016, (86). The PCT application was filed on March 25, 2010, published in English, and designated the United States. Ex. 1017, (22), (81). Nielsen is, therefore, prior art under 35 U.S.C. § 102(e) with an effective filing date of March 25, 2010.

D. Grounds of Unpatentability

We instituted an *inter partes* review of claims 1–13 on the following grounds of unpatentability:

Claims	Reference(s)	Basis
1, 6, 11, and 13	Rhodes and Drachmann '250	§ 103(a)
2	Rhodes, Drachmann '250, and Nielsen	§ 103(a)
3 and 5	Rhodes, Drachmann '250, and Marsh	§ 103(a)
3, 4, 8, and 12	Rhodes, Drachmann '250, and Walker	§ 103(a)
7	Rhodes, Drachmann '250, and Yamamoto	§ 103(a)
9	Rhodes, Drachmann '250, and Buckberry	§ 103(a)
10	Rhodes, Drachmann '250, Nielsen, and Körner	§ 103(a)
1, 2, 6, and 7	Nielsen	§ 102(e)
3 and 5	Nielsen and Marsh	§ 103(a)
3, 4, 8, and 12	Nielsen and Walker	§ 103(a)
9	Nielsen and Buckberry	§ 103(a)
10	Nielsen and Körner	§ 103(a)
11 and 13	Nielsen and Drachmann '311	§ 103(a)

II. ANALYSIS

A. The '559 Patent

The '559 patent relates to an ultrasonic consumption meter for metering fluids such as water or gas when exposed to condensing or other harmful environments. Ex. 1001, 1:6–9. The meter includes a flow channel, ultrasonic transducers and associated electronics, a housing containing the transducers and electronics, and a locking mechanism that locks the housing in position relative to the flow channel. *Id.* at 1:60–67. The locking mechanism can consist of either screws or a locking pin inserted through one or more protrusions in both the housing and flow channel in a direction that

is either parallel or perpendicular to the length of the flow channel. *Id.* at 3:53–54, 3:66–67, 4:4–19, 5:54–57.

The housing for the meter's transducers and electronics includes a cup, a lid, and a hermetic seal (e.g., an O-ring) between the two. Ex. 1001, 2:30–31, 2:54–56. Protrusions on the housing seat the transducers, and are aligned with circular holes in the flow channel to permit the efficient transmission of ultrasonic waves through the fluid flowing through the flow channel. Ex. 1001, 3:58–63, 6:3–9. An insert in the flow channel includes features that either reflect the ultrasonic waves or redirect the flow of fluid in the flow channel. *Id.* at 6:13–19. The insert is held in place by features on the housing that pass through holes in the insert. *Id.* at 6:21–26.

Figure 2 of the '559 patent is reproduced below.

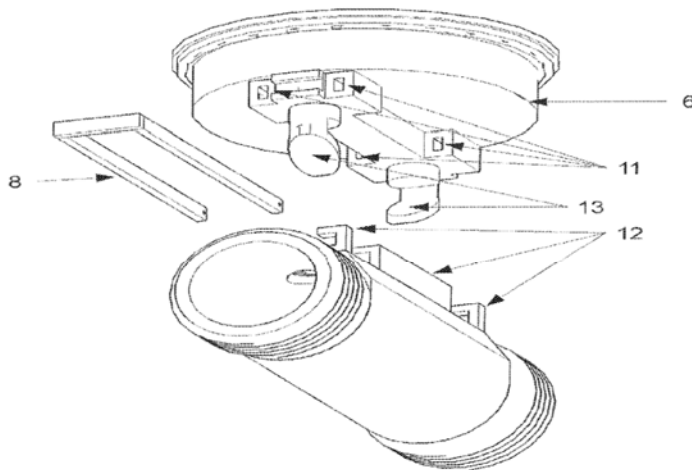

Fig. 2

Figure 2 is an exploded view of the housing, flow channel, and locking pin that constitute the locking mechanism disclosed in the '559 patent. Ex. 1001, 4:35–36.

Figure 2 shows a cup 6 of a housing (not labeled) having protrusions 11 with through holes formed in the protrusions, a flow channel (not labeled) having protrusions 12 with grooves formed in the protrusions, and locking pin 8.

Ex. 1001, Fig. 2. When locking pin 8 is inserted through grooves in protrusions 12 and holes in protrusions 11 in a direction parallel to the length of the flow channel, it locks the housing to the flow channel. *Id.* at 5:55–57, Figs. 1–3, 5a–5d, and 6.

Figure 3 of the '559 patent is reproduced below.

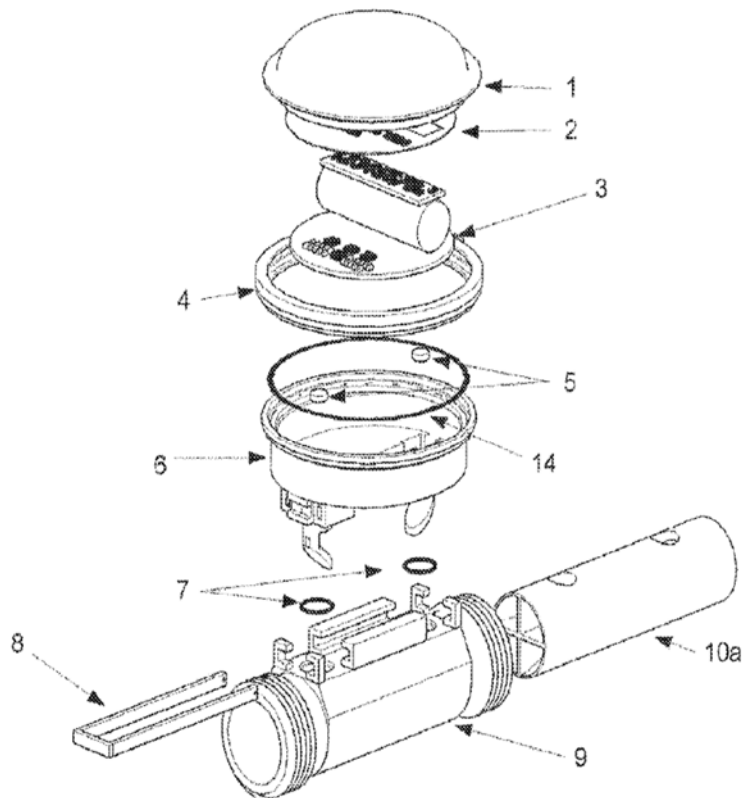

Fig. 3

Figure 3 is an exploded view of the ultrasonic consumption meter disclosed in the '559 patent. Ex. 1001, 4:37.

Figure 3 illustrates a flowmeter having a flow channel 9 with slotted protrusions (not labeled) on its upper surface, and holes (not labeled) through its upper surface. Ex 1001, Fig. 3. An insert 10a having holes (not labeled) in its upper surface can be inserted through an inlet or outlet of flow

channel 9. *Id.* at 6:22–24, Fig. 3. Features (not labeled) on cup 6 of an electronics housing (not labeled) are inserted through O-rings 7 into holes (not labeled) in flow channel 9 and into holes in insert 10a, and thereby hold insert 10a in place. *Id.* at 6:24–26, Fig. 3. Locking pin 8, inserted through the protrusions in cup 6 and flow channel 9 in a direction parallel to the length of the flow channel, locks the electronics housing (not labeled) to flow channel 9. *Id.* at 5:55–57, Fig. 3. The electronics housing (not labeled) consists of lid 1, plate 2, locking ring 4, and cup 6, and is hermetically sealed via O-ring 14. *Id.* at 6:41, 6:52–59, 5:4, 5:23–24, Fig. 3.

Cup 6 includes piezoelectric transducers 5 to generate and detect ultrasonic waves, and printed circuit board 3 to control transducers 5 and determine a metered value based on the rate of fluid flow through flow channel 9. Ex 1001, 3:34–37, 4:60–5:3, 5:16–22, Fig. 3. Printed circuit board 3 includes various electronic components such as a power supply (battery), display, wired or wireless communication interfaces, and a pressure transducer. *Id.* at 3:34–37, 4:60–5:3, Fig. 3. In a preferred embodiment, a wireless communication interface is included to avoid penetration of any electrical connections into the housing. *Id.* at 3:40–42.

Claims 1, 12, and 13 of the '559 patent are independent, and claim 1 is reproduced below.

1. An ultrasonic consumption meter comprising:
 - a flow channel for the media to be measured;
 - at least one ultrasonic transducer for emitting and receiving ultrasound;
 - an electronic circuit for operating the meter; and,
 - a housing for the transducers and the electronic circuit;characterized by

a locking mechanism that locks the housing in position relative to the flow channel; and
wherein the housing consists of a cup, a lid and a hermetical seal.

Ex. 1001, 6:66–7:9

Claim 12 differs from claim 1 in that it (a) does not require the housing to consist of a cup, lid, and hermetical seal, and (b) requires the locking mechanism to comprise at least one protrusion on the housing, at least one protrusion on the flow channel, and a locking pin that can be inserted and extracted by a movement parallel to the length of the flow channel. *Compare* Ex. 1001, 6:66–7:9, *with id.* at 8:6–22. Claim 13 differs from claim 1 in that it (a) does not require the housing to consist of a cup, lid, and hermetical seal, and (b) requires the housing to not be penetrated by electrical wires. *Compare* Ex. 1001, 6:66–7:9, *with id.* at 8:23–31. Other challenged claims depend, directly or indirectly, from claims 1, 12, or 13.

B. Claim Construction

The Board interprets claims of an unexpired patent using the broadest reasonable construction in light of the specification of the patent in which they appear. 37 C.F.R. § 42.100(b); *Cuozzo Speed Techs., LLC, v. Lee*, 136 S. Ct. 2131, 2142–46 (2016). Consistent with the rule of broadest reasonable interpretation, claim terms are generally given their ordinary and customary meaning, as would be understood by one of ordinary skill in the art in the context of the entire disclosure. *See In re Translogic Tech., Inc.*, 504 F.3d 1249, 1257 (Fed. Cir. 2007). Only those terms that are in controversy need to be construed and only to the extent necessary to resolve

the controversy. *Vivid Techs., Inc. v. Am. Sci. & Eng'g, Inc.*, 200 F.3d 795, 803 (Fed. Cir. 1999).

The only term Petitioner asks us to construe is the term “seal” recited in claim 8. Pet. 21. Petitioner argues the term means a “legal” or “tamper-evident” seal. *Id.* Patent Owner does not dispute this interpretation, and does not ask us to construe any claim terms. We decline to construe the term “seal” because it is not necessary to resolve any controversy. *See Vivid Techs.*, 200 F.3d at 803. We need not expressly construe any other term, as the terms are deemed to have their plain and ordinary meaning.

C. Bias of Mr. Skallebæk

Patent Owner argues the Board should give little weight to the Declaration of Petitioner’s expert, Mr. Skallebæk, because “his obvious bias raises immediate questions regarding his statements’ credibility.” PO Resp. 3–4. In particular, Patent Owner argues Mr. Skallebæk’s opinions are biased because he is a Senior Vice President of Petitioner, receives substantial compensation from Petitioner, and has an admitted interest in the outcome of the case. *Id.* at 4. Patent Owner also argues the Board should give little weight to Mr. Skallebæk’s Declaration because it was not written by him, but by another employee of Petitioner who has no experience in the design, testing, or manufacturing of flowmeters. *Id.*

In his Declaration, Mr. Skallebæk indicated his position as Senior Vice President for Petitioner. Ex. 1018 ¶ 1. He further declared that he had read the Petition and the Exhibits thereto, and swore that all statements in the Declaration were true and correct, and signed the Declaration. *Id.* ¶ 2. In his deposition, Mr. Skallebæk testified that although he receives an annual salary from Petitioner, his compensation is independent of the outcome of

this proceeding. Ex. 2007, 16:10–17:20. The evidence does not show that Mr. Skallebæk has any other financial interest in the outcome of the case.

We duly note the interest of Mr. Skallebæk as an Officer of Petitioner in our consideration and weighing of his testimony. *See Ethicon Inc. v. U.S. Surgical Corp.*, 135 F.3d 1456, 1465 (Fed. Cir. 1998). We do not consider the fact that someone else first drafted Mr. Skallebæk’s Declaration, which he reviewed and signed, to diminish the credibility of his testimony in any way.

D. Unpatentability of Claims 1, 2, 6, and 7 over Nielsen

Petitioner argues Nielsen teaches all the limitations of claims 1, 2, 6, and 7, and therefore, anticipates these claims. Pet. 49–53.

Nielsen discloses an ultrasonic flow meter that can be used as either a water or gas meter. Ex. 1016 ¶ 28. The flow meter includes flow meter housing 120 with measuring tube 114, and an attached water tight casing that encloses printed circuit board 202 and transducers 206.⁵ *Id.* ¶ 35. Nielsen’s casing consists of top part 134 hermetically sealed to bottom membrane 132 via soldering, laser welding, or glue. *Id.* ¶¶ 35, 44. The bottom membrane 132 includes first and second recesses 236 for seating transducers 206, and flow meter housing 120 includes first and second holes for receiving the first and second recesses. *Id.* ¶ 38. Bracing 116 is provided to lock the casing to housing 120 via one or more screws. *Id.* ¶ 40.

⁵ Petitioner maps Nielsen’s flow meter housing 120 (which includes measuring tube 114) to the claimed “flow channel,” and Nielsen’s water-tight casing (which contains a circuit board and transducers) to the claimed “housing.” *See* Pet. 50; Ex. 1016 ¶ 35.

Figure 2 of Nielsen is reproduced below.

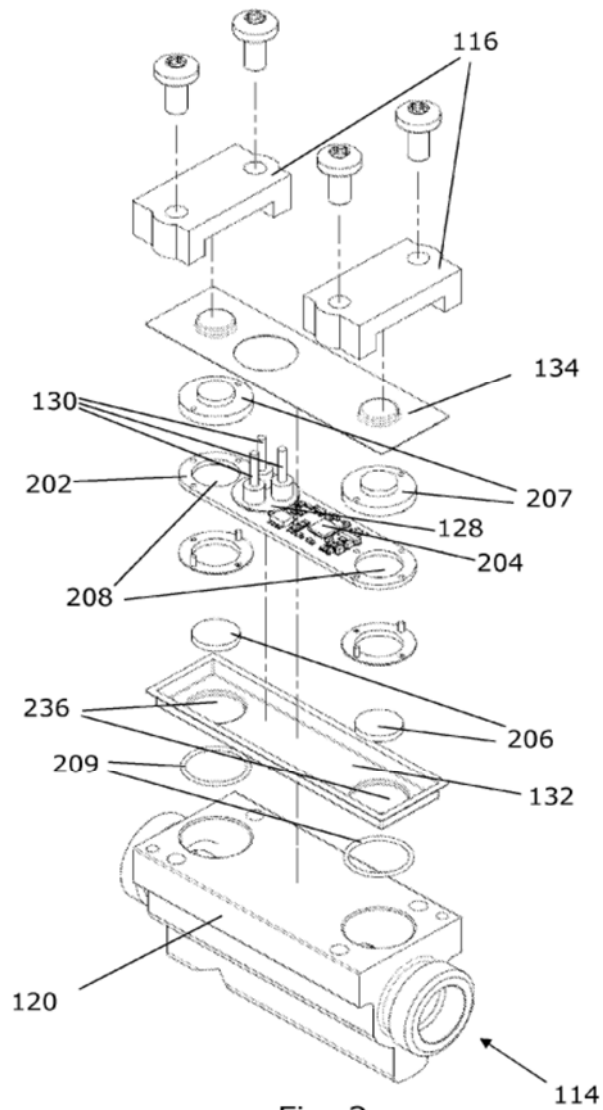

Fig. 2

Figure 2 is an exploded view of an ultrasonic flow meter as taught by Nielsen.

Petitioner demonstrates, by a preponderance of evidence, that Nielsen discloses each of the limitations required by claims 1, 2, 6, and 7. *See* Pet. 49–53. Based on Nielsen’s disclosure, discussed *supra*, we find Petitioner’s analysis persuasive and adopt it as our own. Patent Owner does not contest

Nielsen's anticipation of claim 7, but argues that Nielsen fails to anticipate claims 1, 2, and 6 because the subject matter of these claims was invented by Mr. Drachmann prior to their invention by Nielsen. *See* PO Resp. 5–9, 32.

Priority of invention can be awarded to a party who “can show that it was the first to conceive the invention and that it exercised reasonable diligence in later reducing that invention to practice.”¹¹ *Price v. Symsek*, 988 F.2d 1187, 1190 (Fed. Cir. 1993). To establish conception, a party must provide evidence showing possession of every limitation recited in the claimed invention, including corroborating evidence showing the invention was disclosed to others in such clear terms as to enable those skilled in the art to make the invention. *Coleman v. Dines*, 754 F.2d 353, 359 (Fed. Cir. 1985); *see also Kridl v. McCormick*, 105 F.3d 1446, 1449–50 (Fed. Cir. 1997). The sufficiency of the party's corroborating evidence is determined under a “rule of reason.” *Kridl*, 105 F.3d at 1450; *see also Price*, 988 F.2d at 1195. This requires “a reasoned examination, analysis and evaluation of all pertinent evidence so that a sound determination of the credibility of the inventor's story may be reached.” *Coleman*, 754 F.2d at 360. However, the analysis “does not dispense with the requirement for some evidence of independent corroboration.” *Coleman*, 754 F.2d at 360; *see also Shu-Hui Chen v. Bouchard*, 347 F.3d 1299, 1310 (Fed. Cir. 2003) (“Evidence of the inventive facts must not rest alone on the testimony of the inventor himself”).

Patent Owner proffers the following evidence as proof of conception prior to Nielsen's effective filing date of March 25, 2010: (1) a Declaration by the inventor Mr. Drachmann (Ex. 2008, “Drachmann Declaration”); (2) an email addressed to a Mr. Tunheim dated February 15, 2010, and a

document Mr. Drachmann testifies was attached to the email (Ex. 2009, “first Tunheim email”); (3) an email addressed to Mr. Tunheim dated March 22, 2010, and a presentation that Mr. Drachmann testifies was attached to the email (Ex. 2010, “second Tunheim email”); (4) an email addressed to a Mr. Bjerngaard dated March 22, 2010, and documents that Mr. Drachmann testifies were attached to the email (Ex. 2011, “Bjerngaard email”); (5) a screenshot showing the contents of an archive file on Mr. Drachmann’s personal computer (Ex. 2012, “2D.zip file”); and (6) drawings of a consumption meter (Ex. 2013, “mechanics7 drawings”). PO Resp. 5–8.

In his Declaration, Mr. Drachmann declares a “mechanics6” file was attached to the first Tunheim email and a “UFM++venture” file was attached to both the Bjerngaard and second Tunheim emails. Ex. 2008 ¶¶ 5–10. Although the body of the first Tunheim email refers to a mechanical meter assembly and indicates a sample is attached, there are no indicia in either the body or header of the email indicating a file is attached, let alone a file entitled “mechanics6.” *See* Ex. 2009, 1, 3. Thus, the only evidence that the “mechanics6” file was attached to the first Tunheim email is the Drachmann Declaration. *See* Ex. 2008 ¶ 5. Moreover, the only evidence that the first Tunheim email was actually sent to Mr. Tunheim is the Drachmann Declaration. *Id.* ¶ 5. A similar analysis of the Bjerngaard and second Tunheim emails leads to a similar conclusion, i.e., that the only evidence that a “UFM++venture” file was attached to these emails, or that these emails were sent to their intended recipients is the Drachmann Declaration. *Id.* ¶¶ 6–7; Ex. 2010 1, 3; Ex. 2011 1, 3. Patent Owner has provided no evidence corroborating Mr. Drachmann’s testimony on these points, such as a reply email from Mr. Tunheim or Mr. Bjerngaard, or a declaration from

Mr. Tunheim or Mr. Bjerngaard stating he had received the emails on the dates indicated. *See* Ex. 2008 ¶¶ 5–7.

Moreover, even assuming the first and second Tunheim emails and the Bjerngaard email were sent on the dates indicated and included the “mechanics6” and “UFM++venture” files as attachments, this evidence by itself is insufficient to prove conception of the invention prior to March 22, 2010, because it does not show that the inventors were in possession of every element of the claims. For example, each of independent claims 1, 12, and 13 requires “a housing for the transducers and electronic circuit,” and neither the “mechanics6” file nor the “UFM++venture” file shows transducers located within a housing as required by the claims. *See* Ex. 2009, 4; Ex. 2010, 4–24; Ex. 2011, 54–74. As Petitioner correctly notes, although the devices are referred to as ultrasonic flowmeters in Exhibits 2010 and 2011, “the presence of ‘at least one ultrasonic transducer’ actually inside the device is not apparent in any of the Exhibits themselves, and could be located elsewhere in the fluid flow and still be fully consistent with the content of the Exhibits.” Pet. Reply 2–3.

Patent Owner also relies on the “mechanics7” drawings to prove prior conception of independent claims 1, 12, and 13. *See* Ex. 2008 ¶¶ 14, 21, 22. Although these drawings show the transducers within the housing, Patent Owner presents no evidence indicating these drawings were shown to another person. *See Coleman*, 754 F.2d at 359 (“Conception must be proved by corroborating evidence which shows that the inventor *disclosed to others* his completed thought expressed in such clear terms as to enable those skilled in the art to make the invention”) (emphasis added) (internal quotations and citation omitted).

Moreover, the only evidence Patent Owner presents indicating the “mechanics7” drawings were created *prior* to Nielsen’s effective filing date is the inventor’s own testimony. *See* Ex. 2008 ¶¶ 8–10. The 2D.zip file in which the “mechanics7” drawings are archived indicates these drawings were created or last modified on January 30, 2012, which is well *after* Nielsen’s March 25, 2010 effective filing date. Ex. 2012, 1. Nonetheless, Mr. Drachmann testifies that the drawings were created no later than March 22, 2010 based on (a) his file naming convention, and (b) the drawing on page 3 of the “UFM++venture” file, which Mr. Drachmann testifies is the “mechanics98” drawing listed in the 2D.zip file. Ex. 2008 ¶ 9–10. Although Mr. Drachmann fails to explain his file naming convention, we understand it to mean the creation date of enumerated files follows their enumerated values. In other words, because the “mechanics7” drawings have lower enumerated values than the “mechanics98” drawing, they were created before the “mechanics98” drawing. But, *other than the inventor’s testimony*, Patent Owner has presented no evidence showing the existence or rules of Mr. Drachmann’s file naming convention, no evidence that the “mechanics7” and “mechanics98” drawings were named pursuant to that file naming convention, and no evidence that the “mechanics7” drawings were created *before* the “mechanics98” drawing. Moreover, Patent Owner has presented no *independent corroborating* evidence that the drawing on page 3 of the “UFM++venture” file is the “mechanics98” drawing listed in the 2D.zip file, and as discussed *supra*, Patent Owner has presented no *independent corroborating* evidence that the “UFM++venture” file was attached to the Bjerngaard email or to the second Tunheim email, and no

independent corroborating evidence that these emails were sent to their intended recipients on the days indicated.

In sum, other than Mr. Drachmann's own testimony, Patent Owner has presented no evidence that Mr. Drachmann conceived the subject matter of claims 1, 2, and 6 prior to the effective filing date of Nielsen. As our reviewing court has found:

[C]onception by an inventor, for the purpose of establishing priority, can not be proved by his mere allegation nor by his unsupported testimony where there has been no disclosure to others or embodiment of the invention in some clearly perceptible form, such as drawings or model, with *sufficient proof of identity in point of time*. . . . Hence it has been ruled in many cases that the mere unsupported evidence of the alleged inventor, on an issue of priority, as to ... conception and the time thereof, can not be received as sufficient proof of ... prior conception.

Price, 988 F.2d at 1194–95 (emphasis added) (quoting *Mergenthaler v. Scudder*, 11 App.D.C. 264, 278 (D.C. Cir. 1897)).

Accordingly, accepting as true every statement in Mr. Drachmann's Declaration, we nonetheless agree with Petitioner that Patent Owner has failed to produce sufficient evidence to establish that Mr. Drachmann conceived the inventions recited in claims 1, 2, and 6 of the '559 patent prior to Nielsen's effective filing date. *See* Pet. Reply 1–5. Consequently, we need not consider whether Patent Owner has produced sufficient evidence to show reasonable diligence from just prior to Nielsen's effective filing date until Mr. Drachmann's constructive reduction to practice. We nonetheless note that, like the evidence Patent Owner produced to show conception, the only evidence Patent Owner produced to show Mr. Drachmann's diligence in reducing his invention to practice is his own testimony. *See* Ex. 2008

¶ 12. Consequently, we agree with Petitioner that Patent Owner has also failed to produce sufficient evidence to show Mr. Drachmann exercised reasonable diligence in reducing his invention to practice. *See* Pet. Reply 5–9; *see also Brown v. Barbacid*, 436 F.3d 1376, 1380 (Fed. Cir. 2006) (“Precedent requires that an inventor’s testimony concerning his diligence be corroborated”).

Petitioner has persuasively shown where Nielsen discloses all the limitations recited in claims 1, 2, 6, and 7, and Patent Owner has failed to produce sufficient evidence to show prior invention of the subject matter recited in these claims.⁶ *See* Pet. 49–53. Accordingly, we find Petitioner has demonstrated, by a preponderance of evidence, that claims 1, 2, 6, and 7 of the ’559 patent are anticipated by Nielsen.

E. Unpatentability of Claims 9, 10, 11, and 13 over Nielsen and Buckberry, Körner, or Drachmann ’311

Petitioner demonstrates, by a preponderance of evidence, that claim 9 is unpatentable over the combination of Nielsen and Buckberry, claim 10 is unpatentable over the combination of Nielsen and Körner, and claims 11 and 13 are unpatentable over the combination of Nielsen and Drachmann ’311. *See* Pet. 55–58. Petitioner explains how the teachings of Nielsen can be combined with the respective teachings of Buckberry, Körner, or Drachmann ’311 to account for each of the limitations required by claims 9,

⁶ We note that claims 1, 2, 6, and 7 require a locking mechanism to lock the housing in position relative to the flow channel, but do not require the locking mechanism to include pins. *See* Ex. 1001 6:66–7:12, 7:28–30. The specification indicates the locking mechanism can simply be screws that hold the two pieces together. Spec. 3:53–54, 3:66–67. Nielsen locks the casing to the flow channel housing 120 via screws. Ex. 1016 ¶ 40.

10, 11, and 13, and why the teachings of Nielsen can be properly combined with the respective teachings of Buckberry, Körner, or Drachmann '311. *Id.* We find Petitioner's analysis persuasive and adopt it as our own.

Patent Owner does not contest the unpatentability of claim 9 over Nielsen and Buckberry, but argues claim 10 is patentable over Nielsen and Körner, and claims 11 and 13 are patentable over Nielsen and Drachmann '311 because Mr. Drachmann invented the subject matter of claims 10, 11, and 13 prior to Nielsen. PO Resp. 34–35.

As discussed in § II.D *supra*, Patent Owner has failed to produce sufficient evidence to show that Mr. Drachmann invented the subject matter of claims 10, 11, and 13 prior to Nielsen. Accordingly, we find Petitioner has persuasively shown, by a preponderance of evidence, that claim 9 is unpatentable over Nielsen and Buckberry, claim 10 is unpatentable over Nielsen and Körner, and claims 11 and 13 are unpatentable over Nielsen and Drachmann '311. *See* Pet. 55–58.

F. Unpatentability of Claims 3 and 5 over Nielsen or Nielsen and Marsh

Claim 3 depends from claim 1, and further requires the locking mechanism to have at least one protrusion on the housing, at least one protrusion on the flow channel, and at least one locking pin. Ex. 1001, 7:13–16. Claim 5 depends from claim 3, and further requires the at least one locking pin to be inserted and extracted by a movement perpendicular to the length of the flow channel. *Id.* at 7:21–24.

Petitioner argues Nielsen's flow meter includes flanges extending outward on the flow housing 120, parts of the casing extend out from under bracings 116 on either end, and these components can be considered

protrusions on the flow channel and casing. Pet. 53. Petitioner also argues that Marsh teaches extending a flow meter's housing past its flow channel, and securing the flow channel to the housing via a perpendicularly inserted locking pin. *Id.* at 54. Relying on the Declaration of Mr. Skallebæk, Petitioner argues that it would have been obvious to extend Nielsen's bracing 116 past the bottom of flow channel 120, and to insert a locking pin through the bracing in a direction perpendicular to the flow channel as taught by Marsh. *Id.*

According to Mr. Skallebæk, the Rhodes, Marsh, Nielsen, and Walker references teach different design choices for water meter locking mechanisms. Ex. 1018 ¶ 9. Mr. Skallebæk further declares a person of ordinary skill in the art at the time of the invention would not have needed detailed mechanical designs to know how to modify Nielsen to incorporate the locking mechanism of Marsh, and the modification would have had a reasonable expectation of success and predictable results. *Id.* Therefore, Petitioner argues, it would have been obvious to replace Nielsen's screws with Marsh's locking pin as a matter of design choice. Pet. 53–54 (citing Ex. 1018 ¶ 9). Petitioner further argues the '559 patent confirms the lack of need for a detailed mechanical design for the modification, because the '559 patent “discloses no embodiments of a perpendicular locking pin, but merely states that the locking pin may be ‘parallel or perpendicular’ to the flow channel.” *Id.* at 33.

Patent Owner argues claim 3 is patentable over Nielsen or the combination of Nielsen and Marsh because Mr. Drachmann invented the subject matter of claim 3 prior to Nielsen. PO Resp. 32. As discussed in

§ II.D *supra*, Patent Owner has failed to produce sufficient evidence to show that Mr. Drachmann invented the subject matter of claim 3 prior to Nielsen.

Patent Owner argues that claim 5 is patentable over Nielsen or the combination of Nielsen and Marsh because it would not have been obvious to replace the locking mechanism of Nielsen with the locking mechanism of Marsh. PO Resp. 33. Relying on the testimony of Dr. Johnson, Patent Owner argues that a skilled artisan would not have been motivated to replace the locking mechanism of Nielsen with the locking mechanism of Marsh because the two mechanisms have completely different components, serve completely different purposes, and could not be substituted without major mechanical redesign. *Id.* (citing Ex. 2015 ¶¶ 11, 13, 16–18, 24).

Dr. Johnson declares that a person skilled in the art would not have considered the locking mechanisms of Rhodes, Nielsen, Walker, and Marsh “to be simple design choices available to water meter designers that could be easily substituted for each other,” because they “serve very different purposes.” Ex. 2015 ¶¶ 13–14. Dr. Johnson further testifies that a primary purpose of Nielsen’s locking mechanism is “to keep pressure on the O-rings to maintain the seal keeping the electronics protected and holding the transducers in position relative to the flow channel,” and a primary purpose of Marsh’s locking mechanism is “to lock the flow channel to the rest of the water meter,” “to securely hold the flow channel in place,” and “to eliminate the need to shut down fluid flow during meter servicing.” *Id.* ¶¶ 16–17

We are not persuaded by Patent Owner’s arguments. Although there are differences between the Nielsen and Marsh locking mechanisms, they largely serve the same purpose—locking a water meter to a flow channel to hold the flow channel securely in place. This is admitted by Dr. Johnson,

who declares a primary purpose of Nielsen's locking mechanism is to "hold[] the transducers [which are securely seated in the housing] in position relative to the flow channel" and a primary purpose of Marsh's locking mechanism is to "lock the flow channel to the rest of the water meter." Ex. 2015 ¶¶ 16–17. Moreover, the '559 patent itself confirms Mr. Skallebæk's opinion that screw and pin based locking mechanisms are interchangeable design choices, as the patent indicates that "[a] simple locking mechanism could be screws holding the two pieces together," but a preferred solution is one in which "the housing and . . . flow channel [are] zipped together by . . . one or more locking pins." *See* Ex. 1001, 3:66–4:2, 4:17–19.

Although we agree with Patent Owner that Nielsen would need to be redesigned to incorporate Marsh's locking mechanism, the record contains no evidence that such a redesign would have been beyond the skill of a person of ordinary skill in the art. To the contrary, Petitioner's expert declares a person of ordinary skill in the art would have known that the teachings of Nielsen and Marsh could have been combined "with a reasonable expectation of success and predictable results and no detailed mechanical design would need to be [provided]." Ex. 1018 ¶ 9. The need to modify a reference does not defeat a conclusion of obviousness absent a showing that such modifications would have been beyond the capabilities of a person of ordinary skill in the art. *See, e.g., KSR Int'l Co. v. Teleflex Inc.*, 550 U.S. 398, 417 (2007). ("[I]f a technique has been used to improve one device, and a person of ordinary skill in the art would recognize that it would improve similar devices in the same way, using the technique is obvious unless its actual application is beyond his or her skill.")

Petitioner has explained persuasively how the combined teachings of Nielsen and Marsh account for each of the limitations required by claims 3 and 5, and how and why the references would have been combined. *See* Pet. 53–54. We find Petitioner’s analysis persuasive and adopt it as our own. In particular, we find substituting one known locking mechanism (Nielsen’s screwed bracings) for another (Marsh’s locking pin), when the two locking mechanisms are known design choices, is a sufficient reason to combine Nielsen and Marsh. *See KSR Int’l Co.*, 550 U.S. at 416 (“[W]hen a patent claims a structure already known in the prior art that is altered by the mere substitution of one element for another known in the field, the combination must do more than yield a predictable result.”). Accordingly, we find Petitioner has shown, by a preponderance of evidence, that claims 3 and 5 of the ’559 patent are unpatentable over the combination of Nielsen and Marsh.

G. Unpatentability of Claims 3, 4, 8, and 12 over Nielsen and Walker

Claim 3 depends from claim 1, and further requires the locking mechanism to comprise at least one protrusion on the housing, at least one protrusion on the flow channel, and at least one locking pin. Ex. 1001, 7:13–16. Claim 4 depends from claim 3, and further requires the locking mechanism to be configured so that the at least one locking pin can be inserted and extracted by a movement parallel to the length of the flow channel. *Id.* at 7:17–20. Claim 8 depends from claim 3, and further requires the at least one locking pin to be secured by a seal. *Id.* at 7:29–30. Claim 12 is an independent claim, and requires all the limitations of claims 1, 3, and 4, but does not require the housing to consist of a cup, a lid, and a hermetic seal. *Compare id.* at 6:65–7:20, *with id.* at 8:6–22.

Petitioner argues Nielsen's flow meter includes flanges extending from flow housing 120, parts of the casing extend out from under bracings 116 on either end, and that these components are protrusions on the flow channel and casing. Pet. 54 (referring to analysis of claim 3 ("As described above with respect to Ground 13, Nielsen includes the protrusions of Claim 3, but not the locking pin")). Relying on the Declaration of Mr. Skallebæk, Petitioner proposes modifying Nielsen to incorporate Walker's pin-based locking mechanism by extending bracings 116 past the flanged ends of flow channel housing 120, and including aligned holes in the bracings 116 to accept locking pins inserted along the length of the flow channel housing 120. *Id.* at 54–55 (citing Ex. 1018 ¶ 9).

According to Mr. Skallebæk, the Rhodes, Marsh, Nielsen, and Walker references teach different design choices for water meter locking mechanisms. Ex. 1018 ¶ 9. Mr. Skallebæk further declares a person of ordinary skill in the art at the time of the invention would have understood that a locking mechanism coupling a meter housing and a flow channel including a locking pin extending either parallel or perpendicular to the flow channel could be applied to the housing and flow channel of Nielsen with a reasonable expectation of success and predictable results, and would not have needed detailed mechanical designs to know how to modify Nielsen to incorporate Walker's parallel pin locking mechanism. *Id.*

Patent Owner argues claims 3, 4, and 12 are patentable over Nielsen and Walker because Mr. Drachmann invented the subject matter of these claims prior to Nielsen. As discussed in § II.D *supra*, Patent Owner has failed to produce sufficient evidence to show that Mr. Drachmann invented the subject matter of these claims prior to Nielsen.

Patent Owner argues that claim 8 is patentable over Nielsen and Walker because it would not have been obvious to replace the locking mechanism of Nielsen with the locking mechanism of Walker. PO Resp. 33–34. Relying on the testimony of Dr. Johnson, Patent Owner argues that a skilled artisan would not have been motivated to replace the locking mechanism of Nielsen with the locking mechanism of Walker because the two mechanisms have completely different components, serve completely different purposes, and could not be substituted without major mechanical redesign. *Id.* at 34 (citing Ex. 2015 ¶¶ 13, 14, 16).

Dr. Johnson declares that a person skilled in the art would not have considered the locking mechanisms of Rhodes, Nielsen, Walker, and Marsh “to be simple design choices available to water meter designers that could be easily substituted for each other,” because they “serve very different purposes.” Ex. 2015 ¶¶ 13–14. Dr. Johnson further testifies that a primary purpose of Nielsen’s locking mechanism is “to keep pressure on the O-rings to maintain the seal keeping the electronics protected and holding the transducers in position relative to the flow channel,” and a primary purpose of Walker’s locking mechanism is “to securely lock the entire water meter in place to the supply line.” *Id.* ¶¶ 14, 16.

We are not persuaded by Patent Owner’s arguments. Although we agree with Dr. Johnson that the locking mechanisms of Nielsen and Walker serve somewhat different purposes, “[c]ommon sense teaches . . . that familiar items may have obvious uses beyond their primary purpose.” *KSR*, 550 U.S. at 420. Although the primary purpose of Walker’s locking mechanism is to lock a water meter to a supply line, we agree with Petitioner that a person of ordinary skill in the art would have been able to apply the

teachings of Walker to lock a water meter's housing to its flow channel. *See* Pet. 54–55; *see also KSR*, 550 U.S. at 417 (“When a work is available in one field of endeavor, design incentives and other market forces can prompt variations of it, either in the same field or a different one. If a person of ordinary skill can implement a predictable variation, § 103 likely bars its patentability”).

Moreover, although we agree with Patent Owner that Nielsen would have to be redesigned to incorporate Walker's locking mechanism, we do not agree that this need to redesign Nielsen renders the combination of Nielsen and Walker nonobvious. Petitioner's expert declares the redesign could be achieved without detailed mechanical designs and “with a reasonable expectation of success” (Ex. 1018 ¶ 9); and there is no evidence of record that the redesign would have been beyond the skill of one of ordinary skill in the art. The need to modify a reference does not defeat a conclusion of obviousness absent evidence that such modifications would have been beyond the capabilities of a person of ordinary skill in the art. *See, e.g., KSR*, 550 U.S. at 417. (“[I]f a technique has been used to improve one device, and a person of ordinary skill in the art would recognize that it would improve similar devices in the same way, using the technique is obvious unless its actual application is beyond his or her skill”).

Petitioner has persuasively explained how the combined teachings of Nielsen and Walker account for each of the limitations required by claims 3, 4, 8, and 12, and how and why the references would have been combined. *See* Pet. 54–55. In particular, we find substituting one known locking mechanism (Nielsen's screwed bracings) for another (Walker's locking pin), when the two locking mechanisms are known design choices, is a sufficient

reason to combine Nielsen and Walker. *See KSR Int'l Co.*, 550 U.S. at 416–417. Accordingly, we find Petitioner has shown, by a preponderance of evidence, that claims 3, 4, 8, and 12 of the '559 patent are unpatentable over the combination of Nielsen and Walker.

H. Unpatentability of Claims 1, 6, 11, and 13 over Rhodes and Drachmann '250

Petitioner argues Rhodes teaches all the limitations of claims 1, 6, 11, and 13, except for the requirement of these claims that the housing includes the electronics and transducers, and the requirement of claims 11 and 13 that the housing is not penetrated by electrical wires. Pet. 36.

Figure 3 of Rhodes is reproduced below.

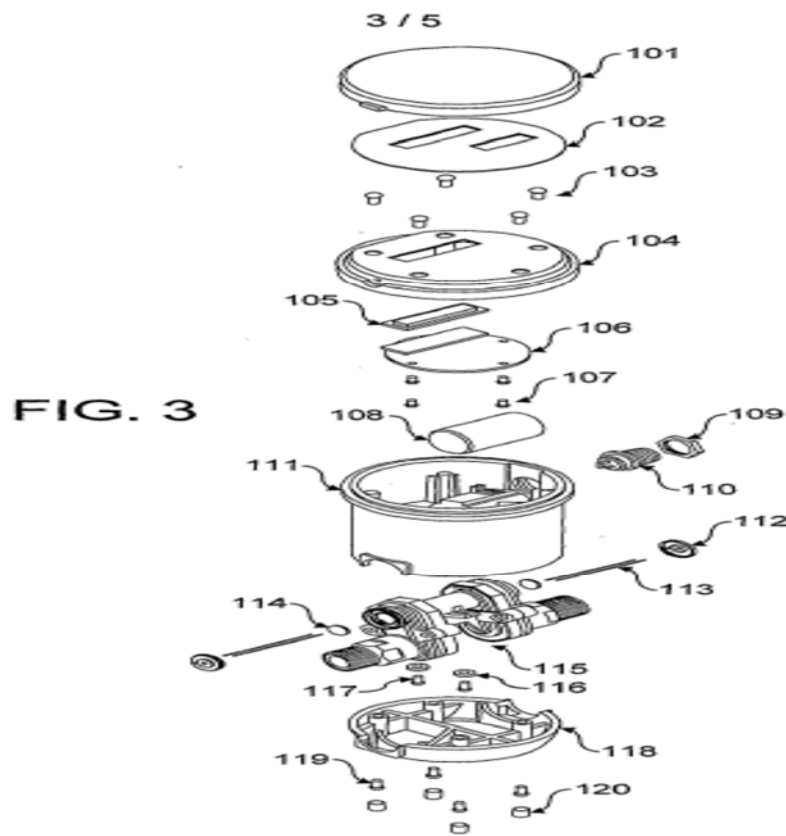

Figure 3 is an exploded view of an ultrasonic consumption meter as taught by Rhodes.

Rhodes teaches a water meter that includes a housing consisting of cup 111 hermetically sealed to lid 104. Ex. 1015, 1:5–7, 5:9–11. The housing encloses printed circuit board 106 and battery 108, i.e., an electronic circuit for operating the meter. *Id.* at 4:2–5. The housing is penetrated by waterproof connector 109 that interfaces printed circuit board 106 with external equipment. *Id.* at 4:5–6. Rhodes’s water meter includes U-shaped flow channel 115 and screws 117, supports 116, and additional supports inside main body 111 to lock the housing to the flow channel. *Id.* at 4:17–22. The meter further includes ultrasonic transducers 114 that are epoxied to the ends of flow channel 115, sealed via caps 112, and wired to printed circuit board 106 via wires 113. *Id.* at 3:2–5, 3:10–16, 4:23–25, Fig. 3.

Based on the disclosures above, we find that Rhodes teaches all the limitations required by claims 1, 6, 11, and 13 except, as Petitioner acknowledges, the limitation that the transducers and electronics are in the same housing, and the limitation that the housing is not penetrated by electrical wires. *See* Pet. 35–43. Petitioner argues that Drachmann ’250 cures these deficiencies “by suggesting a common sealed enclosure for both the ultrasound transducers and the rest of the measurement electronics,” and wireless electronics to eliminate the need for a physical connection to external equipment. *Id.* at 36, 39–40.

The water meter in Drachmann ’250 includes a housing (integral casing) consisting of cup 2 hermetically sealed to lid 3. Ex. 1007, Abstract, ¶¶ 9, 46, Fig. 2. The housing includes printed circuit board 20, battery 21, and ultrasonic transducers (not shown). *Id.* ¶¶ 9, 42–45, Fig. 2. The housing also includes an antenna (not shown) for establishing a two-way

communication link to equipment external to the housing, e.g., to transmit measured values to the external equipment. *Id.* ¶ 43. Figure 2 of Drachmann '250 is reproduced below.

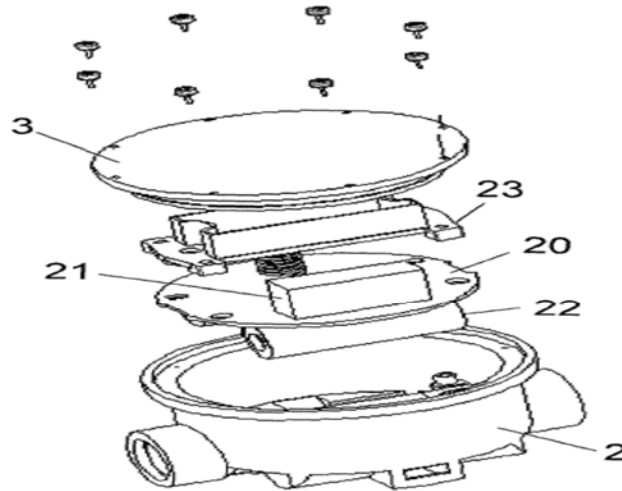

FIG. 2

Figure 2 is an exploded view of a consumption meter as taught by Drachmann '250. Ex. 1007 ¶ 37.

Based on the disclosures above, we agree with Petitioner that Drachmann '250 teaches the limitation that the transducers and electronics are in the same housing, and the limitation that the housing is not penetrated by electrical wires.

Relying on the testimony on Mr. Skallebæk, Petitioner argues it would have been obvious to a person of ordinary skill in the art at the time the '559 patent was filed, to modify Rhodes based on the teachings of Drachmann '250 to hermetically seal the transducers and measurement circuit in the same housing to protect them from environmental damage, and to eliminate the housing's connector to external equipment by wirelessly communicating with that equipment. Pet. 37–39. Petitioner argues sealing the transducers

and measurement circuit in the same housing was a known alternative construction with predictable results, and would eliminate Rhodes' need to separately seal each transducer. *Id.* at 37, 39.

Patent Owner argues Petitioner's reason for combining the teachings of Rhodes and Drachmann '250 is based on hindsight because "[t]he entire teaching of Rhodes clearly stresses the importance of having a single housing with two different sections, one sealed and the other unsealed." PO Resp. 10. Relying on the Declaration of Dr. Johnson, Patent Owner argues a skilled artisan would not have combined the teachings of Rhodes and Drachmann '250 because in Rhodes, "the electronics and transducers are already sealed and protected from the environment so there is no need to seal them again." *Id.* at 12; *see also* Ex. 2015 ¶ 5. Patent Owner further argues that, when considered as a whole, Rhodes teaches the *desirability* of seating the transducers in a *water permeable* housing as opposed to a water impermeable housing as taught by Drachmann '250. *PO Resp.* 12.

We are not persuaded by Patent Owner's arguments. Petitioner does not argue that the combination of Rhodes and Drachmann '250 would have been obvious because combining the references would have separately sealed Rhodes' transducers. To the contrary, Petitioner argues the combination would have been obvious because it would have "*eliminate[d] the need for separate sealing* for each transducer as disclosed in Rhodes." Pet. 39 (emphasis added); *see also* Ex. 1018 ¶ 6. Patent Owner's argument does not persuade us otherwise.

Moreover, although we agree with Patent Owner that Rhodes teaches the importance of sealing transducers *when* they are in a water permeable housing, we disagree that Rhodes teaches the *desirability* of seating the

transducers in such a housing. The passage of Rhodes cited by Patent Owner in support of this interpretation reads: “The transducers are now sealed from water ingress. This is important as the case design allows water to ingress into the bottom part of the enclosure while allowing the equipment to continue to operate due to the sealed transducers and electronics.” Ex. 1015, 3:16–20. This passage simply identifies the need to seal the transducers *when* they are seated in a water permeable housing. It does not teach that it is desirable *to seat* the transducers in such a housing.

By contrast, Drachmann ’250 teaches that it is undesirable to operate water meters in environments that expose the transducers to water or moisture, and that it was known to render water meters used in such environments robust to the penetration of water and moisture by encasing their transducers and electronics in a hermetically sealed housing. Ex. 1007 ¶¶ 4–5, 9. Thus, we agree with Petitioner that it would have been obvious to replace the two sections of Rhodes’ housing, one water impermeable and the other water permeable, with a single-sectioned water impermeable housing as taught by Drachmann ’250 to render the meter robust to the penetration of water and moisture. Accordingly, we are persuaded that Petitioner has provided reasoning with rational underpinning to support modifying Rhodes based on the teachings of Drachmann ’250.

Petitioner has explained, persuasively, how the combined teachings of Rhodes and Drachmann ’250 account for each of the limitations required by claims 1, 6, 11, and 13, and how and why the references would have been combined. *See* Pet. 35–43. Accordingly, we find Petitioner has shown by a preponderance of evidence that claims 1, 6, 11, and 13 are unpatentable over Rhodes and Drachmann ’250.

I. Unpatentability of Claim 2 over Rhodes, Drachmann '250, and Nielsen

Claim 2 depends from claim 1, and further requires the flow channel to have at least one hole for the housing to contact the media. Ex. 1001, 7:10–12. Petitioner argues it would have been obvious to modify Rhodes, based on the teachings of Drachmann '250, to house Rhode's transducers and electronics in a single, sealed housing. *See* Pet. 43. Petitioner argues it would have also been obvious to further modify Rhodes, based on the teachings of Nielsen, to seat the transducers in recesses in the housing and to align the recesses with holes in the flow channel. *Id.* Petitioner argues this further modification to Rhodes would have been obvious to “eliminate the separate wired connections running to each transducer.” *Id.* (citing Ex. 1018 ¶ 7).

Patent Owner argues that claim 2 is patentable over Rhodes, Drachmann '250, and Nielsen because Petitioner's expert, Mr. Skallebæk, never testified that the reason to combine the references would be to eliminate separate wiring to the transducers, and thus, Petitioner's stated reasoning is not supported by evidence. PO Resp. 17. We are persuaded by Patent Owner's argument.

Mr. Skallebæk testifies that:

Nielsen (Ex. 1016) describes a single sealed housing formed in part from a bottom membrane 132 with recesses 236 that hold the transducers. (Ex. 1016, Fig. 2, paragraph [0038]). Rhodes describes an upper sealed chamber defined by a bottom wall that is positioned half way up the main body. (Ex. 1015, page 5, lines 1-2 and 24). As of March 25, 2010, one of ordinary skill in the art reviewing the Nielsen (Ex. 1016) and Rhodes (Ex. 1015) references would have understood that the flow channel holes and transducer containing bottom membrane of Nielsen

could be suitably incorporated into the pipe and main body of Rhodes (Ex. 1015) respectively with a reasonable expectation of success and without altering the functionality of the Rhodes (Ex. 1015) ultrasonic flow meter, and would also have understood that the recesses in the bottom membrane of Nielsen (Ex. 1016) could extend down into the holes of Nielsen (Ex. 1016) far enough to engage an opening in an insert placed in the flow channel, thereby fixing the insert in place, as set forth in the design of Korner (Ex. 1011, 1012, paragraph [0013]).

Ex. 1018 ¶ 7. Although Mr. Skallebæk declares that a person of ordinary skill in the art at the time of the invention would have understood that Nielsen's flow channel holes and housing recesses could be suitably incorporated into Rhodes' pipe (flow channel) and main body (housing) with a reasonable expectation of success, Mr. Skallebæk never declares that a skilled artisan would have incorporated Nielsen's teachings into Rhodes to eliminate the separate wiring of Rhodes' transducers.

Petitioner also cites to a portion of Nielsen that teaches both mounting transducers to a printed circuit board using Surface Mounting Technology (which eliminates wiring), and mounting transducers in housing recesses that align with flow channel holes. *See* Pet. 52–53 (citing Ex. 1016 ¶ 38). However, the cited portion of Nielsen does not teach that the transducers *must be mounted* using Surface Mounting Technology *in order to be mounted* in housing recesses aligned with flow channel holes. *See* Ex. 1016 ¶ 38. Thus, the only evidence offered by Petitioner that a person of ordinary skill in the art, wanting to eliminate the separate wired connections running to Rhodes' transducers, would have modified Rhodes to incorporate Nielsen's teaching to mount the transducers in housing recesses aligned with flow channel holes, is the Petitioner's own conclusory statement to that

effect. *See* Pet. 43. It is not self-evident, however, that wanting to eliminate separate transducer wiring (e.g., using Surface Mounting Technology) would lead a person skilled in the art to seat the transducers in housing recesses aligned with flow channel holes. Nor is it self-evident that seating Rhodes' transducers in housing recesses aligned with flow channel holes would require eliminating the separate wiring of Rhodes' transducers.

Accordingly, we are not persuaded, on this record, that Petitioner has shown by a preponderance of evidence that claim 2 is unpatentable over Rhodes, Drachmann '250, and Nielsen.

J. Unpatentability of Claims 3 and 5 over Rhodes, Drachmann '250, and Marsh

Claim 3 depends from claim 1 and further requires the locking mechanism to include at least one protrusion on the housing, at least one protrusion on the flow channel, and at least one locking pin. Ex. 1001, 7:13–16. Claim 5 depends from claim 3 and further requires the locking mechanism to be configured such that the at least one locking pin can be inserted and extracted by a movement perpendicular to the length of the flow channel. *Id.* at 7:21–24.

Petitioner argues “the device of Rhodes includes a variety of ‘protrusions’ on both the housing and the [flow channel] that are involved in the attachment of the housing to the [flow channel]. A ‘locking pin,’ however, is not shown.” Pet. 44. Petitioner further argues Marsh teaches extending the housing of a flow meter past the flow channel, and securing the flow channel to the housing via a perpendicularly inserted locking pin. *Id.* Relying on the Declaration of Mr. Skallebæk, Petitioner proposes extending the sides of Rhodes's housing 111 past the bottom of Rhodes'

flow channel 115, and inserting the locking pin of Marsh under the flow channel to couple the two extended sides of Rhodes' housing 111, thereby locking the housing to the flow channel. Pet. 44 (citing Ex. 1018 ¶ 8).

Mr. Skallebæk declares the Rhodes, Marsh, Nielsen, and Walker references teach a number of design choices for water meter locking mechanisms. Ex. 1018 ¶ 8. Mr. Skallebæk further declares a person of ordinary skill in the art at the time of the invention would have understood that Marsh's locking mechanism could have been used to lock Rhodes' housing to Rhodes' flow channel with a reasonable expectation of success and predictable results, and without the need for a detailed mechanical design. *Id.* Petitioner argues the '559 patent confirms the lack of need for a detailed mechanical design because the '559 patent "discloses no embodiments of a perpendicular locking pin, but merely states that the locking pin may be 'parallel or perpendicular' to the flow channel." Pet. 33.

Patent Owner argues claims 3 and 5 are patentable over the combination of Rhodes, Drachmann '250, and Marsh because the locking mechanisms of Rhodes, Nielsen, Walker and Marsh are not simple, easily substitutable, design choices. PO Resp. 22. Patent Owner also argues that Petitioner's identification of different locking mechanisms in its analysis of claims 1 and 3 "should weigh against [Petitioner's] assertion that the prior art locking mechanisms are simple design choices." *Id.* at 25. Patent Owner further argues that because the primary functions of the Rhodes and Marsh locking mechanisms are different, a person of ordinary skill in the art would have no reason to substitute one for the other. *Id.* at 23–24. Relying on its expert, Dr. Johnson, Patent Owner argues a primary function of Marsh's locking mechanism is to lock the flow channel to the rest of the meter and to

securely hold it in place, while a primary function of Rhodes' locking mechanism is to keep the water meter components assembled together. *Id.*; *see also* Ex. 2015 ¶¶ 15, 17. Patent Owner further argues that a person of ordinary skill in the art would not know how to substitute Marsh's locking mechanism for Rhodes' without a major redesign, that there would be no reasonable expectation of success without testing the redesign, and that there is no certainty that the redesign would pass the testing. *Id.* at 21, 26; Ex. 2015 ¶ 12.

We are not persuaded by Patent Owner's arguments. Although there are differences between the Rhodes and Marsh locking mechanisms, they largely serve the same purpose—locking a water meter to a flow channel to hold the flow channel securely in place. This is admitted by Dr. Johnson, who declares a primary purpose of Rhodes' locking mechanism is “to keep the water meter components assembled as a complete unit,” and a primary purpose of Marsh's locking mechanism is to “lock the flow channel to the rest of the water meter.” Ex. 2015 ¶¶ 15, 17. Moreover, the '559 patent confirms Mr. Skallebæk's opinion that screw and pin based locking mechanisms are interchangeable design choices, because the '559 patent indicates that “[a] simple locking mechanism could be screws holding the two pieces together,” but a preferred solution is one in which “the housing and flow . . . channel [are] zipped together by . . . one or more locking pins.” *See* Ex. 1001 3:66–4:2, 4:17–19.

As to Patent Owner's argument that Petitioner's mapping of different components of Rhodes to the locking mechanisms required by claims 1 and 3 should weigh against Petitioner's contention that screw and pin based locking mechanisms are interchangeable design choices, we note that

Petitioner's different mappings reflect the differences in the inventions recited in claims 1 and 3. Claim 1 simply requires a locking mechanism to lock the housing to the flow channel, and the specification teaches this can be a simple screw-based locking mechanism. Ex. 1001, 3:66–67, 7:6–7. Consequently, Petitioner identifies a portion of Rhodes indicating the flow channel can be screwed to the housing. *See* Pet. 38. Claim 3 requires the locking mechanism to include protrusions on the housing and flow channel, and a locking pin. Ex. 1001, 7:13–16. Consequently, Petitioner identifies portions of Rhodes showing protrusions on the housing and flow channel that can serve as the needed protrusions when combined with Marsh's pin-based locking mechanism. *See* Pet. 43–44.

Finally, although we agree with Patent Owner that Rhodes would need to be redesigned to incorporate Marsh's locking mechanism, we do not agree that the need to redesign Rhodes renders the combination of Rhodes, Drachmann '250, and Marsh nonobvious. Petitioner's expert declares the redesign could be achieved without detailed mechanical designs and "with a reasonable expectation of success" (Ex. 1018 ¶ 8) and there is no evidence that the redesign would have been beyond the skill of one of ordinary skill in the art. The need to modify a reference does not defeat a conclusion of obviousness absent evidence that such modifications would have been beyond the capabilities of a person of ordinary skill in the art. *See, e.g., KSR*, 550 U.S. at 417. ("[I]f a technique has been used to improve one device, and a person of ordinary skill in the art would recognize that it would improve similar devices in the same way, using the technique is obvious unless its actual application is beyond his or her skill.")

Petitioner has explained, persuasively, how the combined teachings of Rhodes, Drachmann '250, and Marsh account for each of the limitations required by claims 3 and 5, and how and why the references would have been combined. *See* Pet. 43–44. We find substituting one known locking mechanism (Rhodes' screws) for another (Marsh's locking pin) when the two locking mechanisms are known design choices is a sufficient reason to combine Marsh with the combination of Rhodes and Drachmann '250. *See KSR Int'l Co.*, 550 U.S. at 416 (“[W]hen a patent claims a structure already known in the prior art that is altered by the mere substitution of one element for another known in the field, the combination must do more than yield a predictable result.”).

Accordingly, we find Petitioner has shown, by a preponderance of evidence that claims 3 and 5 of the '559 patent are unpatentable over the combination of Rhodes, Drachmann '250, and Marsh.

K. Unpatentability of Claims 3, 4, 8, and 12 over Rhodes, Drachmann '250, and Walker

Claim 3 depends from claim 1, and further requires the locking mechanism to comprise at least one protrusion on the housing, at least one protrusion on the flow channel, and at least one locking pin. Ex. 1001, 7:13–16. Claim 4 depends from claim 3, and further requires the locking mechanism to be configured such that the at least one locking pin can be inserted and extracted by a movement parallel to the length of the flow channel. *Id.* at 7:17–20. Claim 8 depends from claim 3, and further requires the at least one locking pin to be secured by a seal. *Id.* at 7:29–30. Claim 12 is an independent claim. It requires all the limitations of claims 1, 3, and 4,

but does not require the housing to consist of a cup, a lid, and a hermetic seal. *Compare id.* at 6:65–7:20, *with id.* at 8:6–22.

Petitioner argues Rhodes' locking mechanism includes protrusions on housing 111 and flow channel 115, but does not include a locking pin. Pet. 45. Relying on the Declaration of Mr. Skallebæk, Petitioner proposes incorporating Walker's pin-based locking mechanism into Rhodes by "providing the slotted nuts of Walker on each of the threaded ends of the flow channel of Rhodes, with the same locking pin inserted along the flow channel between the nuts." *Id.* (citing Ex. 1018 ¶ 8). Petitioner further proposes modifying Rhodes locking mechanism by securing the locking pin with a lock, thereby forming a seal, as taught by Walker. *Id.*

According to Mr. Skallebæk, the Rhodes, Marsh, Nielsen, and Walker references teach a number of design choices for water meter locking mechanisms. Ex. 1018 ¶ 8. Mr. Skallebæk further declares a person of ordinary skill in the art at the time of the invention would not have needed detailed mechanical designs to know how to modify Rhodes to use Walker's parallel pin locking mechanism, and the modification would have had a reasonable expectation of success and predictable results. *Id.*

Patent Owner argues claims 3, 4, 8, and 12 are patentable over the combination of Rhodes, Drachmann '250, and Walker. PO Resp. 27. Relying on the testimony of Dr. Johnson, Patent Owner argues that a skilled artisan would not have been motivated to substitute Walker's locking mechanism for Rhodes' locking mechanism because the two mechanisms have different constructions and serve different functions. *Id.* at 27–28 (citing Ex. 2015 ¶¶ 13, 18, 19). According to Dr. Johnson, a primary purpose of Rhodes' locking mechanism is "to keep the water meter

components assembled as a complete unit,” and a primary purpose of Walker’s locking mechanism is “to securely lock the entire water meter in place to the supply line.” Ex. 2015 ¶¶ 14–15. Patent Owner further argues that if a skilled artisan “were to combine the references in Petitioner’s proposed way the result would be a locking mechanism that locks the flow channel of Rhodes to the water supply line, not to the housing of Rhodes.” PO Resp. 28. Patent Owner argues Petitioner’s expert, Mr. Skallebæk, admitted as much during his deposition. *Id.* at 29 (citing Ex. 2007, 206:13–209:10).

We are not persuaded by Patent Owner’s arguments. Although we agree with Dr. Johnson that the locking mechanisms of Rhodes and Walker serve somewhat different purposes, “[c]ommon sense teaches . . . that familiar items may have obvious uses beyond their primary purpose[.]” *KSR*, 550 U.S. at 420. Although the primary purpose of Walker’s locking mechanism is to lock a water meter to a supply line, we agree with Petitioner that a person of ordinary skill in the art would have been able to apply the teachings of Walker to lock a water meter’s housing to its flow channel. *See* Pet. 45 (alleging Rhodes can be modified by “providing the slotted nuts of Walker on each of the threaded ends of the flow channel of Rhodes, with the same locking pin inserted along the flow channel between the nuts”); *see also KSR*, 550 U.S. at 417 (“When a work is available in one field of endeavor, design incentives and other market forces can prompt variations of it, either in the same field or a different one. If a person of ordinary skill can implement a predictable variation, § 103 likely bars its patentability”).

Moreover, we disagree with Patent Owner’s argument that a skilled artisan combining the teachings of Rhodes and Walker would lock Rhodes’

flow channel to a water supply line rather than to Rhodes' housing. We do not find Petitioner's challenge to claims 3, 4, 8, and 12 to rely upon a bodily incorporation of Walker's locking mechanism into Rhodes' device. *See In re Keller*, 642 F.2d 413, 425 (CCPA 1981) ("The test for obviousness is not whether the features of a secondary reference may be bodily incorporated into the structure of the primary reference. . . . Rather, the test is what the combined teachings of those references would have suggested to those of ordinary skill in the art"). As to Mr. Skallebæk's alleged admission that the combination of Rhodes and Walker would result in locking Rhodes' flow channel to a supply line, rather than to the housing, we do not find Mr. Skallebæk's testimony amounts to such an admission. *See Ex. 2007*, 206:13–209:10.

Petitioner has explained, persuasively, how the combined teachings of Rhodes, Drachmann '250, and Walker account for the limitations required by claims 3, 4, 8, and 12, and how and why the references would have been combined. *See Pet. 45*. We find substituting one known locking mechanism (Rhodes' screws) for another (Walker's locking pin) when the two locking mechanisms are known design choices is a sufficient reason to combine Walker with the combination of Rhodes and Drachmann '250. *See KSR Int'l Co.*, 550 U.S. at 416–417.

Accordingly, we find Petitioner has shown, by a preponderance of evidence that claims 3, 4, 8, and 12 of the '559 patent are unpatentable over the combination of Rhodes, Drachmann '250, and Walker.

L. Unpatentability of Claims 7 and 9 over Rhodes, Drachmann '250, and Yamamoto or Buckberry

Petitioner demonstrates, by a preponderance of evidence, that claim 7 is unpatentable over the combination of Rhodes, Drachmann '250, and Yamamoto, and that claim 9 is unpatentable over the combination of Rhodes, Drachmann '250, and Buckberry. *See* Pet. 45–46. Petitioner explains, persuasively, how the teachings of Rhodes, modified by the teachings of Drachmann '250, and further modified by the respective teachings of Yamamoto or Buckberry account for each of the limitations required by claims 7 and 9, and how and why the teachings of Rhodes would have been combined with the teachings of Drachmann '250 and Yamamoto or Buckberry.

We find Petitioner's analysis persuasive and adopt it as our own. In particular, we agree with Petitioner that it would have been obvious for the consumption meter described by the combination of Rhodes and Drachmann '250 to be a gas meter as described by Yamamoto because “[w]hen a work is available in one field of endeavor, design incentives and other market forces can prompt variations of it, either in the same field or a different one. If a person of ordinary skill can implement a predictable variation, § 103 likely bars its patentability.” *KSR Int'l Co.*, 550 U.S. at 417. We also agree with Petitioner that it would have been obvious for the consumption meter described by the combination of Rhodes and Drachmann '250 to include a pressure sensor as taught by Buckberry because “if a technique has been used to improve one device, and a person of ordinary skill in the art would recognize that it would improve similar devices in the same way, using the

technique is obvious unless its actual application is beyond his or her skill.”
Id.

Patent Owner argues claims 7 and 9 are patentable over the combination of Rhodes, Drachmann ’250 and Yamamoto or Buckberry for the same reasons that claim 1 is patentable over the combination of Rhodes and Drachmann ’250. PO Resp. 30. We are not persuaded by Patent Owner’s arguments for the reasons discussed in § II.H *supra*.

Accordingly, we find Petitioner has shown, by a preponderance of evidence, that claim 7 is unpatentable over Rhodes, Drachmann ’250, and Yamamoto, and that claim 9 is unpatentable over Rhodes, Drachmann ’250, and Buckberry. *See* Pet. 45–46.

M. Unpatentability of Claim 10 over Rhodes, Drachmann ’250, Nielsen, and Körner

Claim 10 depends from claim 1, and further requires an insert in the flow channel that is fixed in position by one or more features on the cup of the housing. Ex. 1001, 8:1–3. Petitioner argues the combination of Rhodes, Drachmann ’250, and Nielsen, discussed in § II.I *supra*, teaches a consumption meter that includes a housing with ultrasonic transducers seated in recesses in the housing. Pet. 46. Petitioner further argues Körner teaches extending an encapsulated transducer into an opening in a measuring tube that has been inserted into a flow channel to hold the measuring tube in place. *Id.* at 47–48. Relying on the testimony of Mr. Skallebæk, Petitioner argues it would have been obvious to modify the combination of Rhodes, Drachmann ’250, and Nielsen to extend the housing recesses taught by Nielsen into the flow channel to hold a measuring tube insert in place as taught by Körner. Pet. 49; Ex. 1018 ¶ 7.

As discussed in § II.I, *supra*, Petitioner has failed to adequately explain why a person of ordinary skill in the art, wanting to eliminate the separate wired connections running to Rhodes' transducers, would have modified Rhodes to incorporate Nielsen's teaching of mounting the transducers in housing recesses aligned with flow channel holes. *See* Pet. 43. Petitioner does not allege that the combination of Rhodes and Drachmann '250 teaches a consumption meter having a housing with recesses, or a flow channel having holes to accommodate such housing recesses, and does not rely on Körner alone for teaching these features. *See* Pet. 46–49.

Accordingly, we are not persuaded, on this record, that Petitioner has shown by a preponderance of evidence that claim 10 is unpatentable over Rhodes, Drachmann '250, Nielsen, and Körner.

III. CONCLUSION

Petitioner has demonstrated, by a preponderance of the evidence, that claims 1–13 of the '559 patent are unpatentable. In particular, Petitioner has shown, by a preponderance of the evidence, that:

Claims 1, 2, 6, and 7 are anticipated by Nielsen under 35 U.S.C. § 102(e);

Claims 3 and 5 are unpatentable over Nielsen and Marsh under 35 U.S.C. § 103(a);

Claims 3, 4, 8, and 12 are unpatentable over Nielsen and Walker under 35 U.S.C. § 103(a);

Claim 9 is unpatentable over Nielsen and Buckberry under 35 U.S.C. § 103(a);

Claim 10 is unpatentable over Nielsen and Körner under 35 U.S.C. § 103(a);

Claims 11 and 13 are unpatentable over Nielsen and Drachmann '311 under 35 U.S.C. § 103(a).

Claims 1, 6, 11, and 13 are unpatentable over Rhodes and Drachmann '250 under 35 U.S.C. § 103(a);

Claims 3 and 5 are unpatentable over Rhodes, Drachmann '250, and Marsh under 35 U.S.C. § 103(a);

Claims 3, 4, 8, and 12 are unpatentable over Rhodes, Drachmann '250, and Walker under 35 U.S.C. § 103(a);

Claim 7 is unpatentable over Rhodes, Drachmann '250, and Yamamoto under 35 U.S.C. § 103(a); and

Claim 9 is unpatentable over Rhodes, Drachmann '250, and Buckberry under 35 U.S.C. § 103(a).

IV. ORDER

Accordingly, it is:

ORDERED that claims 1–13 of the '559 patent are unpatentable; and

FURTHER ORDERED that, because this Decision is final, a party to the proceeding seeking judicial review of the Decision must comply with the notice and service requirements of 37 C.F.R. § 90.2.

IPR2015-01403
Patent 8,893,559 B2

For PETITIONER:

Thomas R. Arno
Kerry S. Taylor
KNOBBE MARTENS OLSON & BEAR LLP
2tra@knobbe.com
2kst@knobbe.com

For PATENT OWNER:

Richard J. Basile
Todd. M. Oberdick
ST. ONGE STEWARD JOHNSTON & REENS LLC
rbasile@ssjr.com
toberdick@ssjr.com
litigation@ssjr.com