

UNITED STATES PATENT AND TRADEMARK OFFICE

---

BEFORE THE PATENT TRIAL AND APPEAL BOARD

---

MICROSOFT CORPORATION,  
Petitioner,

v.

BISCOTTI INC.,  
Patent Owner.

---

Case IPR2014-01457  
Patent 8,144,182 B2

---

Before MICHELLE R. OSINSKI, NEIL T. POWELL, and  
KEVIN W. CHERRY, *Administrative Patent Judges*.

Opinion for the Board filed by *Administrative Patent Judge* POWELL.

Opinion Dissenting filed by *Administrative Patent Judge*, CHERRY.

POWELL, *Administrative Patent Judge*.

FINAL WRITTEN DECISION  
*35 U.S.C. § 318(a) and 37 C.F.R. § 42.73*

## I. INTRODUCTION

Microsoft Corporation (“Petitioner”) filed a Petition requesting an *inter partes* review of claims 6, 13–16, 24–29, 31–37, 41, 46, and 82–86 of U.S. Patent No. 8,144,182 B2 (Ex. 1001, “the ’182 patent”). Paper 1 (“Pet.”). On March 19, 2015, we instituted an *inter partes* review as to claims 6, 24–26, 28, 29, 31, 36, 37, and 41. Paper 9. On July 20, 2015, pursuant to our authorization, Patent Owner filed a Corrected Patent Owner Response. Paper 30<sup>1</sup> (“PO Resp.”). On August 19, 2015, Petitioner filed a Reply. Paper 34 (“Pet. Reply”).

An oral hearing was held on November 12, 2015. A transcript of the oral hearing is included in the record. Paper 58 (“Tr.”).

We have jurisdiction under 35 U.S.C. § 6(b). This Final Written Decision is issued pursuant to 35 U.S.C. § 318(a) and 37 C.F.R. § 42.73. For the reasons that follow, we determine that Petitioner has not shown, by a preponderance of the evidence, that claims 6, 24–26, 28, 29, 31, 36, 37, and 41 of the ’182 patent are unpatentable.

### A. *Related Proceedings*

Patent Owner has asserted the ’182 patent against Petitioner in *Biscotti Inc. v. Microsoft Corp.*, Case No. 2:13-cv-01015-JRG (E.D.Tex.). Pet. 2; Paper 5, 1. The ’182 patent also is the subject of petitions filed by Petitioner in the following cases: IPR2014-01458 and IPR2014-01459. Pet. 2.

---

<sup>1</sup> Paper 30 is the public version of Patent Owner’s Response. Paper 29 is a confidential version of Patent Owner’s Response, which remains under seal, as explained in Section V, below.

B. The '182 Patent (Ex. 1001)

The '182 patent discloses “tools and techniques for providing video calling solutions.” Ex. 1001, Abst. The '182 patent shows one video communication system 100 in Figure 1A, reproduced below.

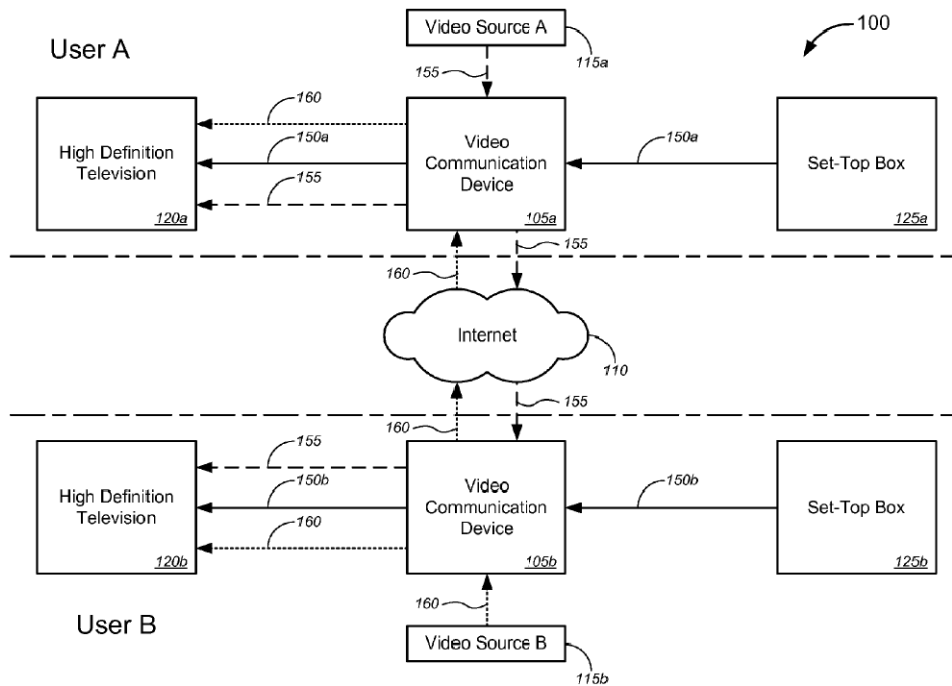

FIG. 1A

Figure 1A shows various components of video communication system 100, including video communication devices 105a and 105b, Internet 110, video sources 115a and 115b, display devices 120a and 120b, and set-top boxes 125a and 125b. *Id.* at col. 5, l. 40–col. 6, l. 13. The '182 patent discloses that video communication device 105a captures video stream 155 from video source 115a, and that video communication device 105b captures video stream 160 from video source 115b. *Id.* at col. 5, ll. 49–56. Each video communication device 105a and 105b can output to the connected display device 120a or 120b a video stream, which may have various compositions. *Id.* at col. 5, ll. 56–62.

As shown in Figure 1A, video communication device 105a may be connected between set-top box 125a and display device 120a. *Id.* at col. 5, ll. 62–65. The '182 patent indicates that this arrangement allows video communication device 105a to pass audiovisual stream 150a from set-top box 125a through to display device 120a. *See id.* at col. 5, l. 62–col. 6, l. 1. The '182 patent discloses that video communication device 105a (additionally or alternatively) may receive audio video stream 160 from video communication device 105b, and that video communication device 105a may forward video stream 160 to display device 120a. *Id.* at col. 6, ll. 1–6. This may happen as part of a video call. *Id.* at col. 6, ll. 1–5. The '182 patent discloses that video communication device 105a, in some cases, may cause simultaneously the display of audiovisual stream 150a from set-top box 125a and stream 160 from video communication device 105b. *Id.* at col. 6, ll. 14–18. This allows a user to watch television while participating in a video call. *Id.* at col. 6, ll. 18–20.

The '182 patent shows more details of one video communication device 105 in Figure 4, reproduced below.

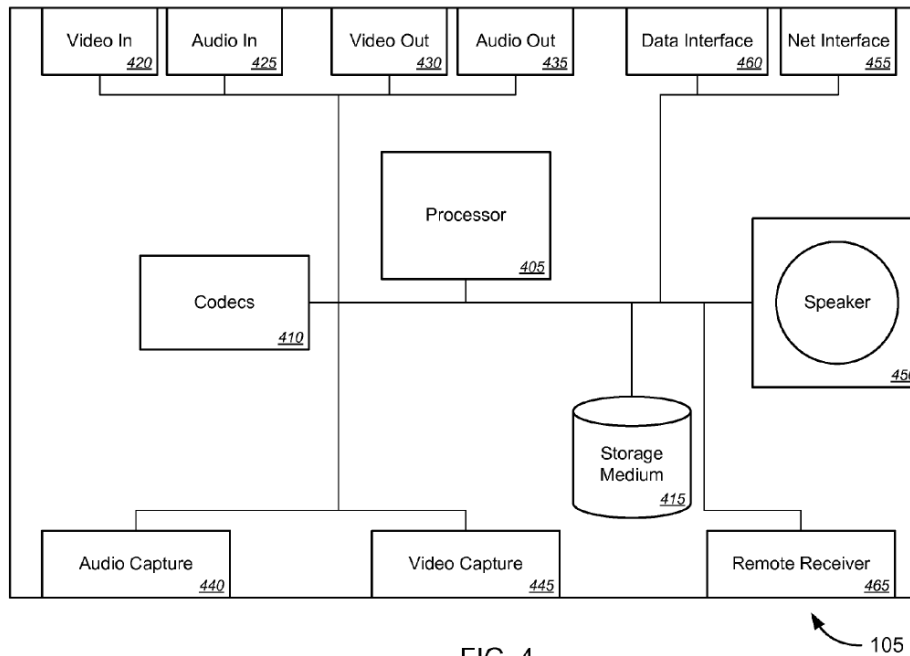

FIG. 4

Figure 4 shows a block diagram of the components composing video communication device 105 and connections between those components. *Id.* at col. 9, ll. 59–64. Video communication device 105 includes input video interface 420 and input audio interface 425, through which video communication device 105 may receive video and audio from a set-top box. *Id.* at col. 10, ll. 19–21, 48–52. Video communication device 105 further includes output video interface 430 and output audio interface 435, through which video communication device 105 may transmit video and audio to a display device. *Id.* at col. 10, ll. 19–22, 59–67. Video communication device 105 also includes audio capture device 440 (such as a microphone) and video capture device 445 (such as a camera), through which video communication device 105 may capture audio and video, such as speech and video footage of a video call participant. *Id.* at col. 11, ll. 3–12.

Video communication device 105 also includes network interface 455, which allows connection to a network and, thereby, communication with a

communication server or another video communication device. *Id.* at col. 11, ll. 25–31. Video communication device 105 may receive an encoded audio or video stream from another video communication device via network interface 455. *Id.* at col. 11, ll. 31–35.

Video communication device 105 also includes processor 405, codecs 410, and storage medium 415. *Id.* at col. 9, ll. 64–66, col. 10, ll. 11–18. Processor 405 generally may control operation of video communication device 105. *Id.* at col. 9, ll. 64–66. Codecs 410 “provide encoding and/or decoding functionality.” *Id.* at col. 10, ll. 13–14. Storage medium 415 “can be encoded with instructions executable by the processor, can provide working memory for execution of those instructions, can be used to cache and/or buffer media streams, and/or the like.” *Id.* at col. 10, ll. 15–18.

*C. Illustrative Claim*

The pending grounds of unpatentability involve claims 6, 24–26, 28, 29, 31, 36, 37, and 41 of the ’182 patent. Claim 6 is independent. The other challenged claims depend, directly or indirectly, from claim 6. Claim 6 is reproduced below:

6. A video communication system, comprising:
  - a first video communication device, comprising:
    - a video input interface to receive video input from a set-top box;
    - an audio input interface to receive audio input from the set-top box;
    - a video output interface to provide video output to a video display device;

- an audio output interface to provide audio output to an audio receiver;
- a video capture device to capture video;
- an audio capture device to capture audio;
- a network interface;
- at least one processor; and
- a storage medium in communication with the at least one processor, the storage medium having encoded thereon a set of instructions executable by the at least one processor to control operation of the first video communication device, the set of instructions comprising:
  - instructions for controlling the video capture device to capture a captured video stream;
  - instructions for controlling the audio capture device to capture a captured audio stream;
  - instructions for encoding the captured video stream and the captured audio stream to produce a series of data packets; and
  - instructions for transmitting the series of data packets on the network interface for reception by a second video communication device.

Ex. 1001, col. 32, l. 62–col. 33, l. 25.

*D. The Prior Art*

The pending grounds of unpatentability in this *inter partes* review are based on the following prior art:

| <b>Exhibits Nos.</b> | <b>References</b>  |
|----------------------|--|
| 1006                 | Kenoyer et al., U.S. Patent No. 7,907,164 B2 (Mar. 15, 2011) (“Kenoyer”)   |
| 1033                 | Danny Briere & Pat Hurley, <i>Windows® XP Media Center Edition 2004 PC for Dummies®</i> (2004) (“Briere & Hurley”) |

*E. Instituted Grounds of Unpatentability*

We instituted an *inter partes* review involving the following grounds of unpatentability:

| Reference(s)                             | Basis    | Claims Challenged                |
|--|----------|----------------------------------|
| Kenoyer                                  | § 102(e) | 6, 24–26, 28, 29, 31, 37, and 41 |
| Kenoyer and Briere & Hurley <sup>2</sup> | § 103(a) | 36                               |
| Kenoyer                                  | § 103(a) | 37                               |

Petitioner supports its challenge with Declarations executed by Henry Houh, Ph.D., on September 5, 2014 (“Houh Declaration”) (Exs. 1003, 1052). Patent Owner relies on a Declaration executed by Alan C. Bovik, Ph.D., on June 9, 2015 (“Bovik Declaration”) (Ex. 2011).

---

<sup>2</sup> Specifically, the Petition asserts that “[c]laim 36 would have been obvious under § 103 based on . . . Kenoyer . . . alone or in view of Briere & Hurley.” Pet. 3.



## II. ANALYSIS

### A. *Claim Interpretation*

In an *inter partes* review, claim terms in an unexpired patent are construed according to their broadest reasonable interpretation in light of the specification. 37 C.F.R. § 42.100(b); *see In re Cuozzo Speed Techs., LLC*, 793 F.3d 1268, 1278–79 (Fed.Cir.2015), *cert. granted sub nom. Cuozzo Speed Techs. LLC v. Lee*, 136 S. Ct. 860 (2016) (No. 15-446). Only those terms in controversy need to be construed, and only to the extent necessary to resolve the controversy. *Vivid Techs., Inc. v. Am. Sci. & Eng’g, Inc.*, 200 F.3d 795, 803 (Fed. Cir. 1999). Based on our analysis below, we determine that no claim terms require express construction for purposes of this Decision.

### B. *Anticipation of Claims 6, 24–26, 28, 29, 31, 37, and 41 by Kenoyer*

#### 1. *Kenoyer (Ex. 1006)*

Kenoyer relates to video conferencing. Ex. 1006, col. 1, ll. 22–23. In Figure 1, Kenoyer “illustrates a videoconferencing system, according to an embodiment.” *Id.* at col. 2, ll. 39–40. Figure 1 is reproduced below.

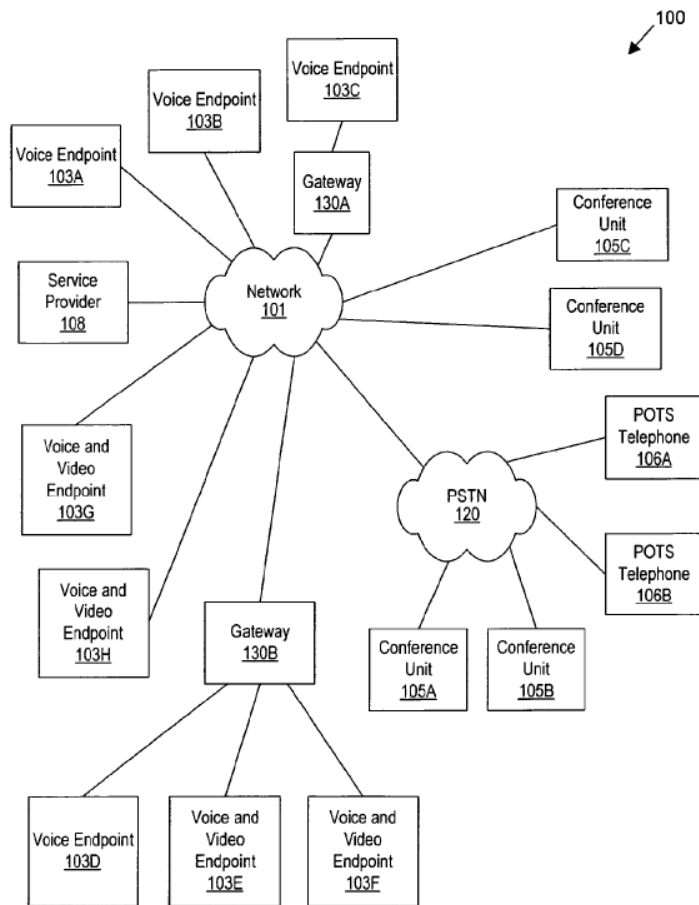

**FIG. 1**

Figure 1 shows the elements of video conferencing system 100, including “network 101, endpoints 103A-103H (e.g., audio and/or videoconferencing systems), gateways 130A-130B, [ ] service provider 108 (e.g., a multipoint control unit (MCU)), [ ] public switched telephone network (PSTN) 120, conference units 105A–105D, and plain old telephone system (POTS) telephones 106A-106B.” *Id.* at col. 3, l. 64–col. 4, l. 4. Each of endpoints 103A–103H, conference units 105A and 105B, and POTS telephones 106A and 106B directly or indirectly couples to network 101. *Id.* at col. 4, ll. 4–14; Fig. 1.

Kenoyer discloses that a multi-component videoconferencing system (MCVCS) may serve as a videoconferencing endpoint. *Id.* at col. 1, ll. 43–45. In Figure 3, Kenoyer “illustrates a participant location with an MCVCS, according to an embodiment.” *Id.* at col. 2, ll. 43–44. Figure 3 is reproduced below.

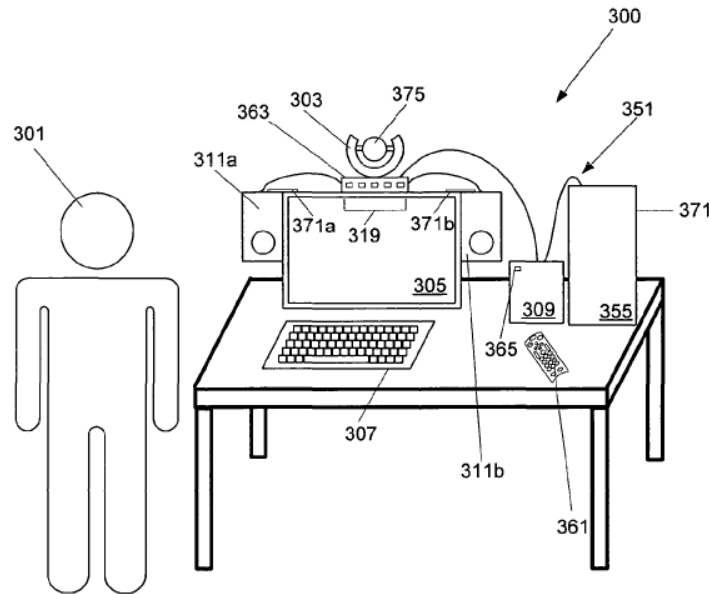
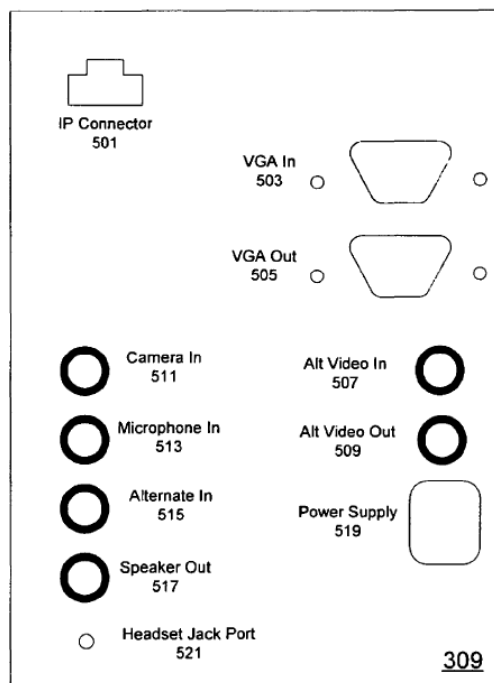

**FIG. 3**

Figure 3 shows elements of MCVCS 300, including camera 303 (with camera base 363 and lens portion 375), display 305, keyboard 307, codec 309, speakers 311a and 311b (with speaker attachments 371a and 371b), microphones 319, network connection 351, computer system 355, remote control 361, and remote sensor 365. *Id.* at col. 6, ll. 4–13, 21–22, 44–47, 50–51; col. 7, ll. 25–26; col. 8, ll. 10–11, 35–47. Regarding microphones 319 and camera 303, Kenoyer discloses that “MCVCS 300 may include microphones 319 to capture participant audio and a camera 303

to capture participant video.” *Id.* at col. 6, ll. 4–6. Regarding display 305 and speakers 311a and 311b, Kenoyer discloses that “MCVCS 300 may also include speakers 311a-b to produce audio from remote conference participants and a display 305 to provide video from local and remote conference participants.” *Id.* at col. 6, ll. 6–9.

Kenoyer shows various ports that an embodiment of codec 309 may have in Figure 5, reproduced below.

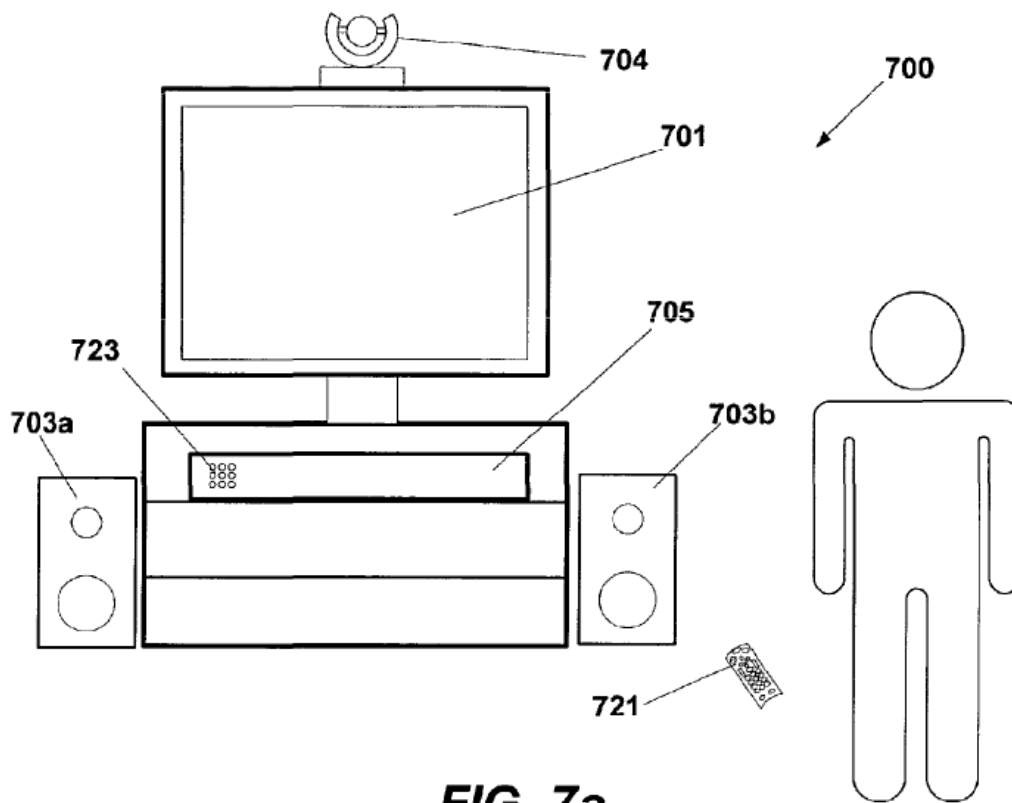

**FIG. 5**

Figure 5 provides a side view of one embodiment of codec 309, showing a number of ports on the side of codec 309. *Id.* at col. 8, ll. 56–57. Codec 309 includes VGA-In 503 and Alternate Video-In 507. *Id.* at col. 8, ll. 60–61. Codec 309 also includes VGA-Out 505 and Alternate Video-Out 509. *Id.* at col. 9, ll. 9–12. Kenoyer discloses that Internet Protocol (IP) port 501 may

be an Ethernet port and may be “included to receive/transmit network signals.” *Id.* at col. 9, ll. 12–14. Kenoyer also discloses “[a]dditional ports (e.g., camera in 511, microphone-in 513, speaker-out 517, etc.)” *Id.* at col. 9, ll. 14–16. Kenoyer further discloses that “[t]he camera and microphone array signals may be sent to the codec 309 through one connection (e.g., alternate input 315).” *Id.* at col. 9, ll. 17–19. Codec 309 also includes power supply port 519 and headset jack port 521. *Id.* at col. 9, ll. 20–21.

In Figures 7a and 7b, Kenoyer illustrates an “MCVCS with codec functionality incorporated in a set-top box, according to an embodiment.” *Id.* at col. 2, ll. 51–52. Figures 7a and 7b are reproduced below.



**FIG. 7a**

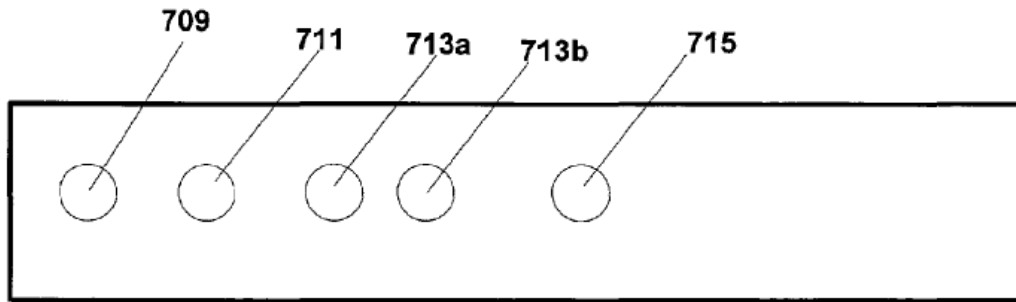

**FIG. 7b**

Figures 7a and 7b show components of MCVCS 700. *Id.* MCVCS 700 includes display 701, speakers 703, camera 704, set-top box 705, remote control 721, and buttons 723 on set-top box 705, camera port 709, S-Video port 711, audio ports 713a-713b, and cable port 715. *Id.* at col. 10, ll. 8–34; col. 11, ll. 1–4. Kenoyer discloses that “[a]s seen in FIGS. 7a-7b, in some embodiments, the codec functionality may be incorporated in a set-top box 705 (e.g., a cable box).” *Id.* at col. 10, ll. 8–10. Kenoyer also discloses that “[t]he codec may also be in an independent housing that is coupled to the set-top box 705. The codec may act as a pass-through for the regular programming/games when a conference is not being held.” *Id.* at col. 10, ll. 25–28.

2. *Claims 6, 24–26, 28, 29, 31, 37, and 41*

Petitioner argues that Kenoyer discloses each limitation of independent claim 6. Pet. 13–20. Petitioner argues that “Kenoyer describes a system including a ‘first video communication device’ in the form of the ‘codec’ and the ‘multi-component video conferencing system’ (MCVCS).” *Id.* at 13 (citing Ex. 1003 ¶¶ 70–72, 232; Ex. 1006, col. 1, ll. 43–60). Petitioner also argues that “Kenoyer discloses that the codec and the

MCVCS have an interface to receive video input from a set top box.” *Id.* at 13–14 (citing Ex. 1003 ¶¶ 71, 92, 233; Ex. 1006, col. 1, l. 65–col. 2, l. 1, col. 10, ll. 25–28). Petitioner further argues that “Kenoyer discloses that the codec/MCVCS has an interface to receive audio input from a set top box.” *Id.* at 14 (citing Ex. 1003 ¶¶ 71–72, 92, 235; Ex. 1006, col. 1, l. 65–col. 2, l. 1; col. 10, ll. 25–28). Petitioner argues that Kenoyer discloses claim 6’s limitation of “a video output interface to provide video output to a video display device,” citing Kenoyer’s disclosure of “VGA Out 505” and “Alt Video Out 509” shown in Figure 5. *Id.* at 15.

Petitioner also argues that “Kenoyer discloses that the codec/MCVCS has an audio output interface to provide audio to an audio receiver.” *Id.* (citing Ex. 1003 ¶ 237). Petitioner elaborates that “Kenoyer discloses outputting audio to speakers and using an interface on the codec to do that” and that “Kenoyer has ports that allow an audio connection between a videoconferencing codec and speakers or a headset, as shown in Figure 5 (‘Speaker Out 517’ ‘Headset Jack Port 521’).” *Id.* (citing Ex. 1003 ¶¶ 81, 85, 95, 237; Ex. 1006, col. 4, ll. 39–46, col. 6, ll. 2–9, col. 8, l. 56–col. 9, l. 34, Fig. 5).

Petitioner also argues that Kenoyer discloses the limitation in claim 6 of “a video capture device to capture video.” *Id.* at 16. Specifically, Petitioner notes that Kenoyer discloses a camera. *Id.*

Petitioner argues that Kenoyer also discloses “an audio capture device to capture audio,” as required by claim 6. *Id.* Specifically, Petitioner notes that Kenoyer discloses a microphone. *Id.*

Petitioner also argues that Kenoyer discloses “a network interface,” as required by claim 6. *Id.* Petitioner asserts that Kenoyer discloses both wired

and wireless connectors, specifically pointing to Kenoyer's disclosure of "IP connector 501" and an RJ-45 connector. *Id.* Petitioner notes that Kenoyer refers to port 501 as "an Ethernet port such as Internet Protocol (IP) port 501." *Id.* (quoting Ex. 1006, col. 9, ll. 12–14).

Petitioner argues that Kenoyer also discloses the limitation of claim 6 of "at least one processor." *Id.* at 16-17. Specifically, Petitioner notes Kenoyer discloses that "[e]mbodiments of a subset or all (and portions or all) of the above may be implemented by program instructions stored in a memory medium or carrier medium and executed by a processor." *Id.* at 16 (alteration in original) (quoting Ex. 1006, col. 15, ll. 21–24). Petitioner further argues that "[o]ne of the patents incorporated by reference into Kenoyer also discusses processors," asserting that Exhibit 1010 is "incorporated by reference as Ser. No. 11/252,238" at column 3, lines 44–48 of Kenoyer. *Id.* (citing Ex. 1010, col. 6, lines 53–67; Ex. 1003 ¶¶ 102, 241).

Petitioner contends that Kenoyer also discloses claim 6's "storage medium" and its "instructions," specifically

a storage medium in communication with the at least one processor, the storage medium having encoded thereon a set of instructions executable by the at least one processor to control operation of the first video communication device, the set of instructions comprising:

instructions for controlling the video capture device to capture a captured video stream;

instructions for controlling the audio capture device to capture a captured audio stream;

instructions for encoding the captured video stream and the captured audio stream to produce a series of data packets; and



instructions for transmitting the series of data packets on the network interface for reception by a second video communication device.

*Id.* at 17–20 (citing Ex. 1003 ¶¶ 72, 95–101, 103, 242, 244–247; Ex. 1006, 4:17–27, 5:64–67, 6:44–47, 9:27–28, 15:8–10, 21–24). Addressing this portion of claim 6, Petitioner states

Claim 6 also requires a “storage medium” having encoded thereon certain computer instructions, which Kenoyer discloses through its description of functionality and its later statement that “[e]mbodiments of a subset or all (and portions or [sic] all) of the above may be implemented by program instructions stored in a memory medium or carrier medium and executed by a processor.”

Pet. Reply 4–5 (alterations in original) (citation omitted) (quoting Ex. 1006, col. 15, ll. 21–24) (citing Pet. 17–19). Petitioner argues that Kenoyer “discloses storing instructions in memory that perform the functionality disclosed therein” and that Kenoyer “discloses the functionality of the list of instructions in claim 6.” Pet. 17. Petitioner and Dr. Houh point to column 15, lines 21–24 of Kenoyer as disclosing “a storage medium . . . having . . . a set of instructions,” as recited in claim 6. *Id.*; Ex. 1003 ¶ 242. At column 15, lines 21–24, Kenoyer states that “[e]mbodiments of a subset or all (and portions or all) of the above may be implemented by program instructions stored in a memory medium or carrier medium and executed by a processor” (the “program-instructions sentence”). Based on this passage, Dr. Houh concludes “[t]hus, Kenoyer describes using computer programs to implement the codec and other functionality described in that patent.” Ex. 1003 ¶ 100.

To address the four specific instructions that claim 6’s “storage medium” comprises, Petitioner and Dr. Houh point to various other portions of Kenoyer as disclosing the functions recited in connection with these instructions. Pet. 17–20; Ex. 1003 ¶¶ 243–47. For example, when addressing the claimed “instructions for encoding the captured video stream and the captured audio stream to produce a series of data packets,” Petitioner and Dr. Houh cite Kenoyer’s disclosure at column 8, lines 10–15 that “the network connection 351 may be from an IP link 371 coupled to the computer system 355 from an external network (other types of links are also contemplated).” Pet. 18–19; Ex. 1003 ¶ 246.

Patent Owner argues that Petitioner has not demonstrated Kenoyer discloses claim 6’s “storage medium” with all four of its specific instructions. PO Resp. 17–23. Patent Owner and Dr. Bovik assert that, contrary to the position taken by Petitioner and Dr. Houh, Kenoyer’s program-instructions sentence does not refer to all of the 34 pages of Kenoyer preceding the program-instructions sentence. PO Resp. 18–21; Ex. 2011 ¶¶ 96–99. Rather, Patent Owner and Dr. Bovik assert that the program-instructions sentence refers back to the immediately preceding disclosure of a videoconferencing method discussed at column 15, lines 1–20 and shown in Figure 22. PO Resp. 18–19; Ex. 2011 ¶ 96. Patent Owner asserts that

This is the only reasonable interpretation of the sentence in the context of the patent, especially in light of the highlighted “embodiments of the methods described below” statement in Column 15, lines 3-4. No part of that method discloses “encoding the captured video stream and the captured audio stream to produce a series of data packets” or “transmitting the series of data

packets on the network interface for reception by a second video communication device.” Ex. 2011 at ¶ 96.

PO Resp. 19.

Patent Owner and Dr. Bovik assert that Petitioner’s and Dr. Houh’s interpretation of the program-instructions sentence as referring to everything in the 34 preceding pages of Kenoyer does not make sense because those preceding pages include many disclosures that cannot be implemented with program instructions. PO Resp. 18–21; Ex. 2011 ¶¶ 97–99. Patent Owner and Dr. Bovik note, for example, that the preceding pages of Kenoyer disclose things like a handle used to carry videoconferencing equipment and a fan used to cool videoconferencing equipment, which cannot be implemented by program instructions. PO Resp. 20–21; Ex. 2011 ¶ 97.

In response, Petitioner argues that the program-instructions sentence “literally refers to the entire disclosure by using the phrase ‘a subset or all . . . of the above.’” Pet. Reply 5 (citing Ex. 1052 ¶ 53; Ex. 1006, 15:21–24). Dr. Houh similarly notes that Kenoyer’s program-instructions sentence refers to “[e]mbodiments of a subset or all (and portions or all) of the above.” Ex. 1052 ¶ 53. Dr. Houh asserts that “[i]t is common to refer to the entire document when using the term ‘of the above.’” *Id.* Dr. Houh also states that the program-instructions sentence “appear[s] at the end of Kenoyer’s specification, where patents commonly offer general broadening disclosures.” *Id.* Petitioner adds that

Indeed, the same column later notes that “[*f*]urther modifications and alternative embodiments of various aspects of *the invention* may be apparent to those skilled in the art in view of this description.” Ex. 1006, 15:55–57. The statement that “further” modifications of aspects of “the invention” confirms that the earlier passage in

column 15 refers to the disclosure as a whole, not just the top of column 15.

Pet. Reply 5 (quoting Ex. 1006, col. 15, ll. 55–57). Dr. Houh asserts that “[t]he term ‘further’ refers to the prior expanding disclosure that, as this clause explicitly says, refers to the entire invention, not just the top of column 15.” Ex. 1052 ¶ 54.

Petitioner also comments on Patent Owner’s and Dr. Bovik’s observation that many of the things Kenoyer discloses, like handles and fans, could not be implemented in program instructions. Pet. Reply 5. Specifically, Petitioner states that “the average artisan would know that a ‘handle’ or ‘fan’ would not be implemented in program instructions and Kenoyer’s statement is not fairly interpreted to mean that such ordinary structures would be implemented in computer instructions.” *Id.* (citing Ex. 1052 ¶ 57; Ex. 1050, 223:22–227:17).

Petitioner also suggests that at least a portion of Kenoyer’s disclosure of a videoconferencing method discussed at column 15, line 1–20 and shown in Figure 22 (to which Patent Owner asserts the program-instructions sentence refers back to) could also not be implemented in program instructions alone, such as a camera or microphone. *See* Tr. 18:3–23. Patent Owner counters that the functions disclosed at column 15, lines 1–20 could be implemented in program instructions (*id.* at 58:2–59:3), whereas many of the functions (like carrying with a handle) that are disclosed in the preceding 34 pages of Kenoyer could not be implemented with program instructions (*id.* at 56:1–57:7).

To demonstrate anticipation, Petitioner must demonstrate that a prior art reference shows every element of the claimed invention identically, in the same relationship as in the claim. *In re Bond*, 910 F.2d 831, 832 (Fed.

Cir. 1990). The invention must have been known to the art in the detail of the claim; that is, all of the elements and limitations of the claim must be shown in a single prior art reference, arranged as in the claim. *Karsten Mfg. Corp. v. Cleveland Golf Co.*, 242 F.3d 1376, 1383 (Fed. Cir. 2001). “[A reference can anticipate a claim even if it ‘d[oes] not expressly spell out’ all the limitations arranged or combined as in the claim, if a person of skill in the art, reading the reference, would ‘at once envisage’ the claimed arrangement or combination.” *Kennametal, Inc. v. Ingersoll Cutting Tool Co.*, 780 F.3d 1376, 1381 (Fed. Cir. 2015) (second alteration in original) (quoting *In re Petering*, 301 F.2d 676, 681 (CCPA 1962)).

As allegedly disclosing claim 6’s “storage medium” and its four specific “instructions for” performing certain functions, Petitioner relies on Kenoyer’s program-instructions sentence as allegedly referring to and tying together a number of disclosures in various portions throughout Kenoyer regarding functions that may be performed in various embodiments.

Pet. 17–20. We are not persuaded by a preponderance of the evidence that a person of ordinary skill in the art would interpret Kenoyer the way Petitioner contends.

For the reasons explained by Patent Owner and Dr. Bovik, Kenoyer’s program-instructions sentence does not make sense as referring to everything in the preceding 34 pages of Kenoyer. *See* PO Resp. 18–21; Ex. 2011 ¶¶ 96–99. Thus, Petitioner’s and Dr. Houh’s observations that the program-instructions sentence appears near the end of Kenoyer and refers to “all . . . of the above” do not persuade us that the program-instructions sentence refers to the preceding 34 pages. Nor are we persuaded by Petitioner’s argument that column 15, lines 1–20 discloses objects, such as a

camera and a microphone that could not be implemented in program instructions. This argument does not make it any more likely that the program-instructions sentence refers to all of the preceding 34 pages than that it refers to the disclosure at column 15, lines 1–20.

We also find unpersuasive Petitioner’s and Dr. Houh’s observation that a subsequent portion of Kenoyer discloses that “[f]urther modifications and alternative embodiments of various aspects of the invention may be apparent to those skilled in the art in view of this description” (the “further-modifications sentence”). Ex. 1006, col. 15, ll. 55–57; Pet. Reply 5; Ex. 1052 ¶ 54. Neither Petitioner nor Dr. Houh cites any basis for reading the further-modifications sentence as referring specifically to the program-instructions sentence (*see* Pet. Reply 5; Ex. 1052 ¶ 54), and we find no basis for reading Kenoyer in this manner. The further-modifications sentence is separated from the program-instructions sentence by an entire paragraph referring to “some embodiments” in which “a computer system at a respective participant location may include a memory medium(s) on which one or more computer programs or software components according to one embodiment of the present invention may be stored.” Ex. 1006, col. 15, ll. 46–54. We find that Kenoyer’s program-instructions sentence does not make sense as a disclosure blanketing all of the preceding 34 pages.

Additionally, we find that the program-instructions sentence does not refer back specifically to the various other disclosures cited by Petitioner. Instead, the program-instructions sentence vaguely refers to “a subset or all (and portions or all) of the above.” Ex. 1006, col. 15, ll. 21–22. Patent Owner’s argument and evidence that “the above” refers to the method disclosed at column 15, lines 1–20 is at least as persuasive as Petitioner’s

argument and evidence that “the above” refers to the various other portions of Kenoyer cited by Petitioner. *See* PO Resp. 18–21; Ex. 2011 ¶¶ 96–99. It makes sense that a videoconferencing method would lend itself to implementation with program instructions. As such, it makes sense that the program-instructions sentence would refer specifically to the videoconferencing method disclosed at column 15, lines 1–20. Additionally, because the disclosure at column 15, lines 1–20 refers to a method that does not include structures like a handle or a fan, Patent Owner’s position is consistent with Petitioner’s contention that “the average artisan would know that a ‘handle’ or ‘fan’ would not be implemented in program instructions and Kenoyer’s statement is not fairly interpreted to mean that such ordinary structures would be implemented in computer instructions.” Pet. Reply 5; PO Resp. 18–21. Furthermore, we agree with Patent Owner that, considered together, Kenoyer’s reference at column 15, lines 3–4 to “embodiments of the methods described below” and the reference at column 15, lines 21–22 to “[e]mbodiments of a subset or all (and portions or all) of the above” appear to both refer to the method disclosed between these statements. *See* PO Resp. 19.

Petitioner’s challenge relies on the program-instructions sentence as “disclos[ing] storing instructions in memory that perform the functionality disclosed therein.” Pet. 19 (citing Ex. 1003 ¶¶ 100–101, 242; Ex. 1006, col. 15, ll. 21–24). We find it to be at least equally likely that the program-instructions sentence refers only to the method disclosed at column 15, lines 1–20 (as asserted by Patent Owner) as that the program-instructions sentence refers to the entirety of Kenoyer’s disclosure (as asserted by Petitioner). Therefore, Petitioner has not demonstrated by a preponderance of the

evidence that the program-instructions sentence relates to the entirety of Kenoyer's disclosure so as to tie together the functions that may be performed throughout Kenoyer in order to anticipate a claim directed to instructions encoded on a storage medium. We find that Petitioner has not demonstrated by a preponderance of the evidence that Kenoyer's program-instructions sentence and various other cited portions disclose the claimed "storage medium" with its four specific "instructions for," or that a person of ordinary skill in the art would "at once envisage" a storage medium with the specific instructions claimed. A storage medium with program instructions and the functions of (i) controlling the video capture device to capture a captured video stream; (ii) controlling the audio capture device to capture a captured audio stream; (iii) encoding the captured video stream and the captured audio stream to produce a series of data packets; and (iv) transmitting the series of data packets on the network interface for reception by a second video communication device are unrelated to each other in Kenoyer's disclosure. *See NetMoneyIN Inc. v. VeriSign, Inc.*, 545 F.3d 1359, 1369 (Fed. Cir. 2008) ("[D]ifferences between the prior art reference and a claimed invention, however slight, invoke the question of obviousness, not anticipation. . . . [To anticipate], it is not enough that the prior art reference discloses . . . multiple, distinct teachings that the artisan might somehow combine to achieve the claimed invention."); *see also In re Arkley*, 455 F.2d 586, 587 (CCPA 1972) ("The [prior art] reference must clearly and unequivocally disclose the claimed [invention] or direct those skilled in the art to the [invention] without *any* need for picking, choosing, and combining various disclosures not directly related to each other by the teachings of the cited reference."). In other words, because we are not persuaded by



Petitioner's contention that the program-instructions sentence links a storage medium having program instructions to the functions that may be performed in various embodiments, Petitioner has not provided persuasive evidence that the disclosure would be understood by one of ordinary skill in the art to mean that the storage medium with program instructions and the functions performed in the various embodiments are used together in Kenoyer.

Accordingly, we find that Petitioner has not demonstrated by a preponderance of the evidence that claim 6 is anticipated by Kenoyer.<sup>3</sup>

We respectfully disagree with the dissent for the reasons discussed above, and because Petitioner did not present arguments corresponding to much of the dissent's analysis. Indeed, Petitioner's presentation of its case bears little resemblance to the dissent's analysis. The thrust of Petitioner's arguments is that Kenoyer expressly discloses the disputed claim limitations, not what a person of ordinary skill in the art would envisage or understand based on what Kenoyer does disclose. *See, e.g.*, Pet. 17 (“Kenoyer discloses storing instructions in memory that perform the functionality disclosed therein.”); Pet. Reply 4–5 (“Claim 6 also requires a ‘storage medium’ having encoded thereon certain computer instructions, . . . , which Kenoyer discloses through its description of functionality and its later statement that ‘[e]mbodiments of a subset or all (and portions or [sic] all) of the above may be implemented by program instructions stored in a memory medium or

---

<sup>3</sup> We note Petitioner's statement relating to the alleged obviousness of encoding data to create data packets and sending audio and video using those packets “[t]o the extent the disclosure of the IP protocol could be said not to disclose encoding into packets.” Pet. 19, n.1. There is no indication, however, that Petitioner's challenge is based on the alleged obviousness of a storage medium having encoded thereon a set of instructions comprising the four certain functions.

carrier medium and executed by a processor.’ . . . The passage, . . . , literally refers to the entire disclosure by using the phrase ‘a subset or all . . . of the above.’” (alterations in original) (citation omitted)). Thus, even if we agreed with the dissent’s analysis regarding what a person of ordinary skill in the art would understand from Kenoyer’s disclosure, we do not agree that Petitioner carried its burden. *See, e.g.*, 37 C.F.R. § 42.22(a) (2) (requiring Petition to include “[a] full statement of the reasons for the relief requested, including a detailed explanation of the significance of the evidence including material facts, and the governing law, rules, and precedent”).

Each of claims 24–26, 28, 29, 31, 37, and 41 depends, directly or indirectly, from claim 6. Accordingly, each of claims 24–26, 28, 29, 31, 37, and 41 includes claim 6’s “storage medium” and its four “instructions for” performing certain functions. When addressing claims 24–26, 28, 29, 31, 37, and 41, Petitioner does not provide evidence or argument that overcomes the shortcomings in Petitioner’s assertion that Kenoyer discloses claim 6’s “storage medium” with its four specific “instructions for” performing certain functions. *See* Pet. 20–25, 29–32; Pet. Reply 7–13. Accordingly, we find Petitioner has not demonstrated by a preponderance of the evidence that Kenoyer anticipates claims 24–26, 28, 29, 31, 37, and 41.

*C. Obviousness of Claim 36 over Kenoyer and Briere & Hurley*

Claim 36 depends indirectly from claim 6. Accordingly, claim 36 includes claim 6’s “storage medium” and its four “instructions for” performing certain functions. As noted above in Section II.B.2, Petitioner asserts that Kenoyer discloses these limitations, but Petitioner has not demonstrated by a preponderance of the evidence that Kenoyer does disclose

these limitations as arranged in the claim. In the portion of the Petition that explains Petitioner's assertion that claim 36 would have been obvious over Kenoyer and Briere & Hurley, Petitioner does not address claim 6's "storage medium" and the four "instructions for" performing functions. Pet. 53–55. Accordingly, Petitioner has not demonstrated by a preponderance of the evidence that claim 36 would have been obvious over Kenoyer and Briere & Hurley.

*D. Obviousness of Claim 37 over Kenoyer*

Claim 37 depends indirectly from claim 6. Accordingly, claim 37 includes claim 6's "storage medium" and its four "instructions for" performing certain functions. As noted above in Section II.B.2, Petitioner asserts that Kenoyer discloses these limitations, but Petitioner has not demonstrated by a preponderance of the evidence that Kenoyer does disclose these limitations as arranged in the claims. In the portion of the Petition that explains Petitioner's assertion that claim 37 would have been obvious over Kenoyer, Petitioner does not address claim 6's "storage medium" and the four "instructions for" performing functions. *Id.* at 55–56. Accordingly, Petitioner has not demonstrated by a preponderance of the evidence that claim 37 would have been obvious over Kenoyer.

### III. PETITIONER'S MOTION TO EXCLUDE

We have reviewed Petitioner's Motion to Exclude (Paper 40), Patent Owner's Opposition to the Motion (Papers 50, 51)<sup>4</sup>, and Petitioner's Reply in support of the Motion (Paper 54). Petitioner moves to exclude Exhibits 2020–2039. Because our decision does not rely on any of the challenged exhibits, we *dismiss* Petitioner's Motion to Exclude as *moot*.

### IV. PATENT OWNER'S MOTION TO EXCLUDE

We have reviewed Patent Owner's Motion to Exclude Evidence (Paper 44), Petitioner's Response to the Motion (Paper 47), and Patent Owner's Reply in support of the Motion (Paper 55). Patent Owner moves to exclude Exhibits 1005, 1007–1009, 1015–1024, 1026, 1028–1032, 1037–1043, 1054, and 1058–1060. Because our decision does not rely on any of the challenged exhibits, we *dismiss* Patent Owner's Motion to Exclude Evidence as *moot*.

### V. MOTIONS TO SEAL

Patent Owner filed a number of documents (Exhibits 2012, 2029, 2030, 2038, 2048; Papers 29, 50) under seal, along with Motions to Seal (Papers 24, 31, 49) and a protective order (Exhibit 2046, the "Stipulated Protective Order"), to which Patent Owner and Petitioner have stipulated. Petitioner filed Exhibit 1049 under seal, along with a Motion to Seal (Paper 35). In its Motion to Seal, Petitioner notes that "Petitioner and Patent

---

<sup>4</sup> Paper 50 is a confidential version of Patent Owner's Opposition, which Patent Owner filed under seal. Paper 51 is a redacted version of Patent Owner's Opposition.

Owner have stipulated to entry of the Stipulated Protective Order.”<sup>5</sup> Paper 35, 2. We hereby grant entry of the parties’ Stipulated Protective Order.

There is an expectation that information will be made public where the information is identified in a final written decision, and that confidential information that is subject to a protective order ordinarily becomes public 45 days after final judgment in a trial, unless a motion to expunge is granted. 37 C.F.R. § 42.56; Office Patent Trial Practice Guide, 77 Fed. Reg. 48,756, 48,761 (Aug. 14, 2012). In rendering this Final Written Decision, it was not necessary to identify, nor discuss in detail, any confidential information. However, a party who is dissatisfied with this Final Written Decision may appeal the Decision pursuant to 35 U.S.C. § 141(c), and has 63 days after the date of this Decision to file a notice of appeal. 37 C.F.R. § 90.3(a). Thus, it remains necessary to maintain the record, as is, until resolution of an appeal, if any.

In view of the foregoing, the confidential documents filed in the instant proceeding will remain under seal, at least until the time period for filing a notice of appeal has expired or, if an appeal is taken, the appeal has concluded. The record for the instant proceeding will be preserved in its entirety, and the confidential documents will not be expunged or made public, pending appeal. Notwithstanding 37 C.F.R. § 42.56 and the Office Patent Trial Practice Guide, neither a motion to expunge confidential documents nor a motion to maintain these documents under seal is necessary or authorized at this time. *See* 37 C.F.R. § 42.5(b).

---

<sup>5</sup> Petitioner refers to Exhibit 2041 as being the Stipulated Protective Order. Paper 35, 2. We interpret this as a typographical error, as the Stipulated Protective Order was filed as Exhibit 2046.

## VI. CONCLUSION

For the reasons expressed above, we determine that Petitioner has *not* shown by a preponderance of the evidence that

- (1) Claims 6, 24–26, 28, 29, 31, 37, and 41 are anticipated by Kenoyer;
- (2) Claim 36 would have been obvious over Kenoyer and Briere & Hurley; and
- (3) Claim 37 would have been obvious over Kenoyer.

VII. ORDER

For the reasons given, it is:

ORDERED claims 6, 24–26, 28, 29, 31, 36, 37, and 41 of the '182 patent have *not* been shown to be *unpatentable*;

FURTHER ORDERED that Petitioner's Motion to Exclude is *dismissed as moot*;

FURTHER ORDERED that Patent Owner's Motion to Exclude is *dismissed as moot*;

FURTHER ORDERED that the parties' Stipulated Protective Order is entered;

FURTHER ORDERED that Patent Owner's Motions to Seal Papers 29 and 50, as well as Exhibits 2012, 2029, 2030, 2038, and 2048 are *granted*;

FURTHER ORDERED that Petitioner's Motion to Seal Exhibit 1049 is *granted*; and

FURTHER ORDERED that because this is a Final Written Decision, parties to the proceeding seeking judicial review of the Decision must comply with the notice and service requirements of 37 C.F.R. § 90.2.

CHERRY, *Administrative Patent Judge*, dissenting.

I respectfully dissent. The majority finds that Petitioner failed to show by a preponderance of the evidence that Kenoyer discloses the “program instruction” limitations of claim 6. I disagree for two reasons. First, even accepting the majority’s interpretation of Kenoyer’s “program instructions” sentence (Ex. 1006, 15:21–25), I still believe that Petitioner has established sufficiently that Kenoyer discloses the “program instruction” limitations recited in claim 6. Second, I disagree with the majority that Petitioner has failed to show that the “program instructions” sentence applies to all of the embodiments of Kenoyer.

Although the majority is correct that anticipation requires that a single prior art reference disclose the invention “as arranged in the claim,” *NetMoneyIN Inc. v. VeriSign, Inc.*, 545 F.3d 1359, 1369 (Fed. Cir. 2008), I do not agree with their finding that a person of ordinary skill on reading the description of Kenoyer could not “at once envisage” the claimed invention, *Kennametal, Inc. v. Ingersoll Cutting Tool Co.*, 780 F.3d 1376, 1381 (Fed. Cir. 2015). Most importantly, “in considering the disclosure of a reference, it is proper to take into account not only specific teachings of the reference but also the inferences which one skilled in the art would reasonably be expected to draw therefrom.” *In re Preda*, 401 F.2d 825, 826 (CCPA 1968) (citing *In re Shepard*, 319 F.2d 194 (CCPA 1963)). Petitioner presents persuasive evidence that Kenoyer describes a video communication system that performs all of the functions recited in the “instructions for”<sup>6</sup>

---

<sup>6</sup> For purposes of this decision, we have assumed that the “instructions for” limitations are not means-plus-function limitations. Although I have doubts



limitations. Ex. 1003 ¶¶ 241–248. Kenoyer (through another patent incorporated by reference) further discloses that these functions are performed by a processor. Ex. 1003 ¶ 102 (quoting Ex. 1010, 6:53–67). Even assuming that Kenoyer did not disclose expressly the use of program instructions, I am persuaded by the evidence presented that a person of ordinary skill would recognize its description as disclosing the use of program instructions (software) to enable the performance of these functions. *See* Ex. 1052 ¶ 57; *see also In re Alappat*, 33 F.3d 1526, 1583 (Fed. Cir. 1994) (en banc) (Rader, J., concurring) (“Indeed, the line of demarcation between a dedicated circuit and a computer algorithm accomplishing the identical task is frequently blurred and is becoming increasingly so as the technology develops. In this field, a software process is often interchangeable with a hardware circuit.”). I agree with Petitioner this is the most natural inference a person of ordinary skill would draw from a full review of Kenoyer. *See* Ex. 1052 ¶¶ 50–57.

Even though I believe that Kenoyer has sufficient disclosure without the “program instructions” sentence (Ex. 1006, 15:21–25), I believe that, contrary to the majority’s findings, that this sentence also supports a finding of anticipation. Patent Owner’s suggestion that this sentence only applies to the embodiment immediately preceding it does not hold water. The language of the paragraph that contains the “program instructions” sentence is generic and broad. *See id.* at 15:21–45. In contrast, the paragraph immediately preceding it is specific and tied to Figure 22. *Id.* at 15:1–20. Also, the expansive, open language at the beginning of the sentence that

---

about this assumption, I do not address whether these limitations are subject to 35 U.S.C. § 112 ¶ 6, because no party has raised it here.

“[e]mbodiments of a subset or all (and portions or all) of the above may be implemented in program instructions” does not suggest that this is limited to any particular embodiment. *Id.* at 15:21–22. This understanding is confirmed by Kenoyer’s repeated and expansive use of the word “embodiments” (over 73 times throughout the specification in addition to its use in the “program instructions” sentence). I also agree with Petitioner that this reading is confirmed further by the remaining paragraphs of column 15 and 16 (*id.* at 15:46–16:3), which indisputably apply to the entire disclosure, and are written in similar broad generic terms. *See* Ex. 1052 ¶¶ 52–54.

Patent Owner and its declarant argue that under Petitioner’s interpretation “Kenoyer discloses instructions stored in memory to perform the function of ‘carrying the integrated videoconferencing system’ by a handle,’ . . . or to perform the function of ‘cooling the components of the integrated videoconferencing system’ by a ‘fan,’ . . . and any functions necessary for those functions.” Ex. 2011 ¶ 97. This argument is not credible. As Dr. Bovik (wisely) conceded at his deposition, a person of ordinary skill would not think that a handle or a fan is implemented using program instructions. Ex. 1050, 223:22 – 227:17. Thus, this evidence from Patent Owner should not be given any weight.

Finally, I note that even if this specific sentence was only meant to apply to the embodiment described in column 15, lines 1–20, there is no evidence to support the conclusion that such a reading would somehow imply all of the other functions that a person of ordinary skill would recognize could be implemented using program instructions are not to be implemented using program instructions.

Therefore, I disagree with the majority’s conclusion that Petitioner

IPR2014-01457  
Patent 8,144,182 B2

failed to show by a preponderance of the evidence that Kenoyer discloses the “program instructions” limitations and I respectfully dissent.

IPR2014-01457  
Patent 8,144,182 B2

PETITIONER:

Joseph Micallef  
Jeffrey Kushan  
Douglas Lewis  
Sidley Austin LLP  
jmicallef@sidley.com  
jkushan@sidley.com  
dilewis@sidley.com

PATENT OWNER:

Amanda Hollis  
Kirkland & Ellis LLP  
amanda.hollis@kirkland.com