

UNITED STATES PATENT AND TRADEMARK OFFICE

BEFORE THE PATENT TRIAL AND APPEAL BOARD

GARMIN INTERNATIONAL, INC. and
GARMIN USA, INC.
Petitioner

v.

CUOZZO SPEED TECHNOLOGIES LLC
Patent Owner

Case IPR2012-00001
Patent 6,778,074

Before JAMESON LEE, MICHAEL P. TIERNEY, and JOSIAH C. COCKS,
Administrative Patent Judges.

LEE, *Administrative Patent Judge.*

FINAL WRITTEN DECISION
35 U.S.C. § 318(a) and 37 C.F.R. § 42.73

BACKGROUND

A. Introduction

Petitioner, Garmin International Inc. and Garmin USA, Inc. (“Garmin”), filed a petition on September 16, 2012, for *inter partes* review of claims 1-20 of Patent 6,778,074 (“the ’074 Patent”) pursuant to 35 U.S.C. §§ 311 et seq. On January 9, 2013, the Board denied the petition as to claims 1-9, 11-13, 15, 16, and 18-20, and instituted trial for claims 10, 14, and 17, on two grounds of unpatentability. Paper 15.

After institution of trial, Cuozzo Speed Technologies LLC, (“Cuozzo”) filed a Patent Owner Response (“PO Resp.”). Paper 31. Cuozzo also filed a Motion to Amend Claims by substituting proposed new claims 21-23 for claims 10, 14, and 17. Paper 32. Garmin filed a Reply (Paper 40) to the Patent Owner Response, and also its Opposition (Paper 39) to Cuozzo’s Motion to Amend Claims. Cuozzo then filed a Reply (Paper 44) to Garmin’s Opposition to Cuozzo’s Motion to Amend Claims.

Oral hearing was held on August 16, 2013.¹

The Board has jurisdiction under 35 U.S.C. § 6(c). This final written decision is issued pursuant to 35 U.S.C. § 318(a) and 37 C.F.R. § 42.73.

Garmin has shown that claims 10, 14, and 17 are unpatentable.

Cuozzo’s Motion to Amend Claims is *denied*.

B. The Invention of the ’074 Patent²

The disclosed invention of the ’074 Patent relates to a speed limit indicator and method for displaying speed and the relevant speed limit for use in connection

¹ A transcript of the oral hearing is included in the record as Exhibit 3005.

² The Board has added a copy of the ’074 patent as Exhibit 3006.

with vehicles. Ex. 3006, 1:9-11. Specifically, the speed limit indicator and the method for displaying speed and the relevant speed limit have particular utility in connection with displaying the current speed of a vehicle and how it relates to the legal speed limit at the current location of a vehicle. Ex. 3006, 1:11-16. The invention eliminates the need for the driver to take his or her eyes off the road to look for speed limit signs, and resolves any confusion that might exist as to what is the current legal speed limit. Ex. 3006, 1:22-25. The specification states that by allowing the driver to keep his or her eyes on the road more, the speed limit indicator reduces the chance of an accident. Ex. 3006, 1:27-29.

Only one embodiment is described in the specification of the '074 Patent with a meaningful degree of specificity. It is a mechanical embodiment that does not make use of a liquid crystal display for displaying speed or how the current speed relates to the speed limit for the current location of the vehicle.

Figure 1 is reproduced below:

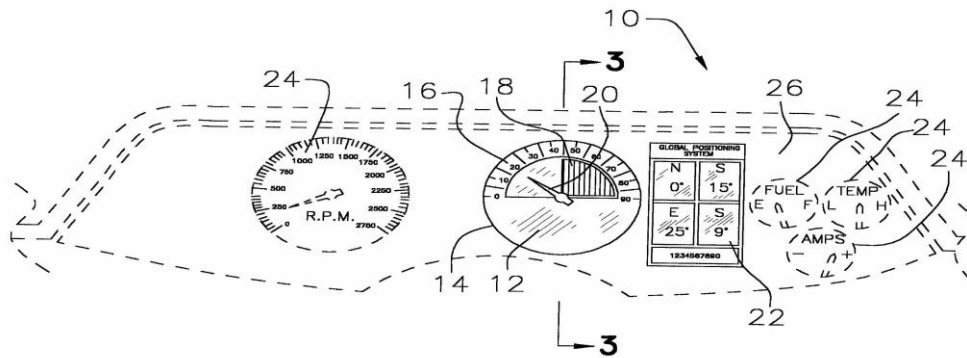

FIG. 1

Figure 1 illustrates a specifically disclosed embodiment. In that embodiment, speedometer 12 is mounted on dashboard 26. Ex. 3006, 5:8-9. It has a backplate 14 made of plastic, speed denoting markings 16 painted on backplate

14, a colored display 18 made of a red plastic filter, and a plastic needle 20 rotatably mounted in the center of backplate 14. Ex. 3006, 5:8-11. A global positioning system receiver 22 is positioned adjacent to speedometer 12, and other gauges typically present on a vehicle dashboard 26 are also provided. Ex. 3006, 5:13-15.

Figure 2 is reproduced below:

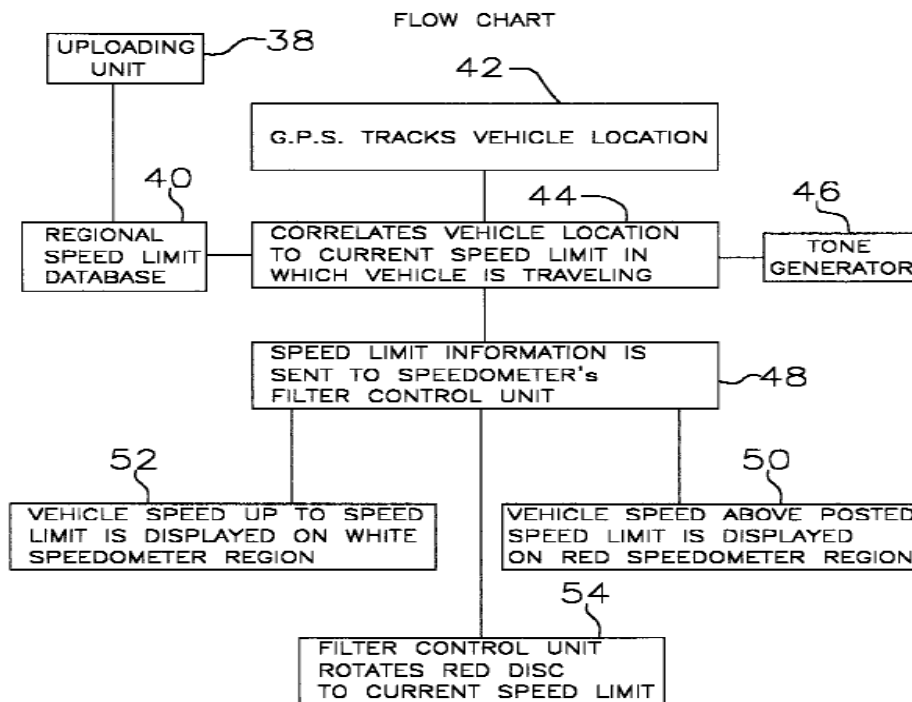

FIG. 2

Figure 2 illustrates in block diagram form the steps carried out by a speed limit indicator shown in Figure 1. Referring to the flowchart of Figure 2, the specification of the '074 Patent describes operation of the speed limit indicator as follows (Ex. 3006, 5:25-39, emphasis added):

Uploading unit **38** uploads current data to a regional speed limit database **40**. The global positioning system receiver **42** tracks the vehicle's location and speed, and identifies the relevant speed limit

from the database for that location. The global positioning system receiver compares the vehicle's speed and the relevant speed limit **44**, and uses a tone generator **46** to generate a tone in the event that the vehicle's speed exceeds the relevant speed limit. The speed limit information is sent from the global positioning system receiver to a filter control unit **48**. **The control unit adjusts the colored filter so that the speeds above the legal speed limit are displayed in red 50 while the legal speeds are displayed in white 52. This is accomplished by the control unit rotating the red filter disc 54 to the appropriate degree.**

Thus, in the step shown in block 54, a filter control unit rotates a red filter disc, which is element 18 in Figure 1, to cover portions of the speed display on speedometer 12, such that readings covered or overlapped by the red filter disc reflect speeds above the speed limit for the current location of the vehicle.

In column 6 of the '074 Patent, lines 31-34, there is brief mention of a different embodiment. It also is stated generally (Ex. 3006, 6:11-14):

And although a red filter disc has been described, it should be appreciated that the colored display herein described could also take the form of a liquid crystal display.

In that regard, claim 12, which depends on claim 10, also recites that "said colored display is a liquid crystal display." Ex. 3006, 7:15-16. The above-quoted text does not describe any specific implementation and indicates only generally that a liquid crystal display may be used in place of the red filter disc. That does not describe an embodiment in which the speed readings themselves "and" the delineation of which speeds are above the speed limit at the current location are both shown on the same liquid crystal display. As is noted by Garmin (Reply at 3, n.1), the liquid crystal display simply may provide colored lighting to a conventional mechanical speedometer needle and backplate.

Similarly, claim 18, which depends on claim 10, recites “wherein said speedometer comprises a liquid crystal display,” but does not provide any manner of specific implementation. It only indicates, generally, that the speedometer may include a liquid crystal display. That does not describe an embodiment in which the speed readings themselves “and” the delineation of which readings are above the speed limit are both shown on the same liquid crystal display.

During oral argument, counsel for Cuozzo acknowledged that even if the features added by dependent claims 12 and 18 are considered together, the combination does not require use of one liquid crystal display to show both speed readings themselves and a delineation of whether the current speed exceeds an applicable speed limit for the current location of the vehicle. Ex. 3005, 78:6-9.

C. The Alleged Grounds of Unpatentability

The prior art references as applied to claims 10, 14, and 17 are:

Aumayer	U.S. 6,633,811	Oct. 14, 2003; filed Oct. 19, 2000	Ex. 1001
Awada	U.S. 6,515,596	Feb. 4, 2003; filed Mar. 8, 2001	Ex. 1010
Tegethoff	German DE 19755470 A1 English Translation	Sept. 24, 1998	Ex. 1002 Ex. 1003
Evans	U.S. 3,980,041	Sept. 14, 1976	Ex. 1009
Wendt	U.S. 2,711,153	June 21, 1955	Ex. 1011

Citations to Tegethoff refer to its English translation, Ex. 1003.

The Board instituted trial on the following grounds of unpatentability:

Reference(s)	Basis	Claims Challenged
Aumayer, Evans, and Wendt	§ 103	10, 14, 17
Tegethoff, Awada, Evans, and Wendt	§ 103	10, 14, 17

DISCUSSION

An appropriate construction of the term “integrally attached” in independent claim 10 is central to the patentability analysis of claims 10, 14, and 17.

Claim 10 is reproduced below (emphasis added):

10. A speed limit indicator comprising:

a global positioning system receiver;

a display controller connected to said global positioning system receiver, wherein said display controller adjusts a colored display in response to signals from said global positioning system receiver to continuously update the delineation of which speed readings are in violation of the speed limit at a vehicle’s present location; and

a speedometer integrally attached to said colored display.

Claim 10 requires that a speedometer be “integrally attached” to a colored display, which is adjustable to update continuously the delineation of which speeds are in violation of the speed limit at the vehicle’s present location. Claim 14 depends on claim 10, and claim 17 depends on claim 14.

A. Claim Construction

Principles of Law

In an *inter partes* review, claim terms in an unexpired patent are interpreted according to their broadest reasonable construction in light of the specification of the patent in which they appear. 37 C.F.R. § 42.100(b); *Office Patent Trial Practice Guide*, 77 Fed. Reg. 48756, 48766 (Aug. 14, 2012). Claim terms are also given their ordinary and customary meaning as would be understood by one of ordinary skill in the art in the context of the entire disclosure. *In re Translogic Tech., Inc.*, 504 F.3d 1249, 1257 (Fed. Cir. 2007).

If an inventor acts as his or her own lexicographer, the definition must be set forth in the specification with reasonable clarity, deliberateness, and precision. *Renishaw PLC v. Marposs Societa' per Azioni*, 158 F.3d 1243, 1249 (Fed. Cir. 1998). Neither Petitioner nor Patent Owner contends that the specification of the '074 Patent, as filed, coined a new meaning for any term.

If a feature is not necessary to give meaning to what the inventor means by a claim term, it would be “extraneous” and should not be read into the claim. *Renishaw PLC*, 158 F.3d at 1249; *E.I. du Pont de Nemours & Co. v. Phillips Petroleum Co.*, 849 F.2d 1430, 1433 (Fed. Cir. 1988). The construction that stays true to the claim language and most naturally aligns with the inventor’s description is likely the correct interpretation. *See Renishaw PLC*, 158 F.3d at 1250.

Board’s Construction of “integrally attached”

According to plain and common usage, the central characteristic of “integrally attached” stems from the word “attached.” That is because the term “integrally” modifies “attached” by specifying a form of attachment. The general characteristic of two components being “attached” to each other cannot be eliminated whatever is the effect of adding “integrally” to modify “attached.”

For a speedometer to be “integrally attached” to a colored display, there must be a speedometer and a colored display that are separately identifiable from each other, or else “attached” effectively would be read out of the claim. Adding the modifier “integrally” does not negate or nullify “attached.” That does not mean the speedometer and the colored display may not share any part. But it does mean that the sharing may not be so substantial, e.g., the entirety of the colored display is subsumed within the speedometer, that the speedometer and the colored display lose their separate identities. It would be illogical to regard one unit as being “attached” to itself.

The Board construes “integrally attached” as applied to the colored display and the speedometer in the context of the disclosure of the ’074 Patent as meaning:
discrete parts physically joined together as a unit without each part losing its own separate identity.

In the joined unit, the colored display is still the colored display and the speedometer is still the speedometer; each retains its own separate identity. That is consistent with the specification. With reference to Figure 1, the specification of the ’074 Patent discloses that colored display 18 in the form of a red plastic filter is a separate item from backplate 14, speed denoting marking 16 on backplate 14, and needle 20. Ex. 3006, 5:9-12. All of those other components, exclusive of the red plastic filter, form the speedometer, which is separate from the colored display.

Cuozzo’s Construction of “integrally attached”

Cuozzo disagrees with the Board’s construction, and argues that “integrally attached” should be construed to mean: joined or combined to work as a complete unit. PO Resp. 3. On the surface, it would appear that the difference between the Board’s construction and Cuozzo’s construction is that Cuozzo’s construction is broader and encompasses the Board’s construction, because Cuozzo’s construction

does not require two separate parts to retain their separate identities. In actuality, however, Cuozzo's construction is not broader.

If Cuozzo's construction is broader and encompasses the Board's construction, then whatever prior art that applies under the Board's construction still applies under Cuozzo's construction and claims 10, 14, and 17 would be equally unpatentable. Responding to the Board's inquiry at oral argument, counsel for Cuozzo acknowledged that Cuozzo's construction is "not" just broader than the Board's construction. Ex. 3005, 62:6-22.

Cuozzo's construction is diametrically different from the Board's construction, because Cuozzo reads its construction as requiring an "integral display" in the sense that there are no longer separate identities between the speedometer and the colored display. Cuozzo's arguments are directed to an "integral display" rather than a speedometer that is "integrally attached" to a colored display as actually is recited in claim 10.

Cuozzo's construction reads out the "attached" portion of the "integrally attached" recitation in the claim. Cuozzo effectively converts the claim feature actually claimed to an "integral display" that shows both current speed readings and the delineation of which speed readings are in violation of the speed limit. During oral argument, counsel for Cuozzo indicated that under Cuozzo's construction, there has to be a display that both functionally and structurally integrates the speedometer and the colored display, such that there only is a single display. Ex. 3005, 36:3-37:18.

The Specification and Prosecution History

The term "integrally attached" does not appear in the specification and original claims of the application, which was filed on March 18, 2002, and later issued as the '074 Patent. The term was proposed during examination by

amendment to application claims 1 and 11 to distinguish over Awada.³ Ex. 1013, 1-3. In the remarks submitted with that amendment, support for the feature that the speedometer is “integrally attached” to the colored display is said to exist in parts of the specification that are now column 5, lines 9-12, column 5, lines 45-49, and Figures 1, 3, and 4 of the ’074 Patent. Ex. 1013, 7:23-25.

The above-quoted portions of the specification describe speedometer backplate 14, speed denoting markings 16 painted on backplate 14, and plastic needle 20, as separate and discrete elements from the colored display 18, which is a rotatable red plastic filter. The specification of the ’074 Patent discloses that colored display 18, in the form of a red plastic filter, is a separate item from backplate 14, speed denoting marking 16 on backplate 14, and needle 20, which form a speedometer separate from the red plastic filter. Ex. 3006, 5:9-12.

Thus, Cuozzo relied on separate and discrete components, joined as one unit, as providing written description support for “integrally attached.”

We are cognizant that the specification of the ’074 Patent states: “Speedometer **12** has a backplate **14** made of plastic, speed denoting markings **16** painted on backplate **14**, a colored display **18** made of a red plastic filter, and a plastic needle **20** rotatably mounted in the center of backplate **14**.” Ex. 3006, 5:9-12. That is an expression that speedometer 12 includes colored display 18, which appears to be contrary to the Board’s construction of “integrally attached.” But there is no such inconsistency, as is explained below.

With respect to the mechanical embodiment shown in Figure 1 and described in column 5, lines 9-12, and column 5, lines 45-49, even though there is language referring to speedometer 12 as including colored display 18, there is no language referring to speedometer 12 as being “integrally attached” to the colored

³ Application claim 11 issued as patent claim 10.

display 18. Had there been such language, coexistent with language noting that the speedometer includes the colored display, we would accord it appropriate weight.

Speedometer 12 is a speedometer with or without red plastic filter 18. It is speedometer 12 without the red plastic filter 18 that is “integrally attached” to the colored display that is red plastic filter 18. Cuozzo does not contend, and reasonably cannot contend, that speedometer 12 is not a speedometer unless colored display 18 is a component of the speedometer. The construction that stays true to the claim language, e.g., “integrally attached,” and most naturally aligns with the inventor’s description is likely the correct interpretation. *See Renishaw PLC*, 158 F.3d at 1250. It is illogical to regard an apparatus as being attached to a component completely contained within itself.

When amending application claims to distinguish the claimed invention from Awada, the applicant stated, Ex. 1013, 7:25-8:2:

The cited Awada (6,515,596) lacks a speedometer integrally attached to the speed limit display (column 2, lines 40-42 and Figs. 1 and 4-6). The vehicle’s driver is forced to look in two separate locations and then mentally compare the speed limit with his vehicle’s speed to determine how close he is to speeding if he is not already doing so sufficiently to activate the light and/or tone.

Figure 1 of Awada is reproduced below:

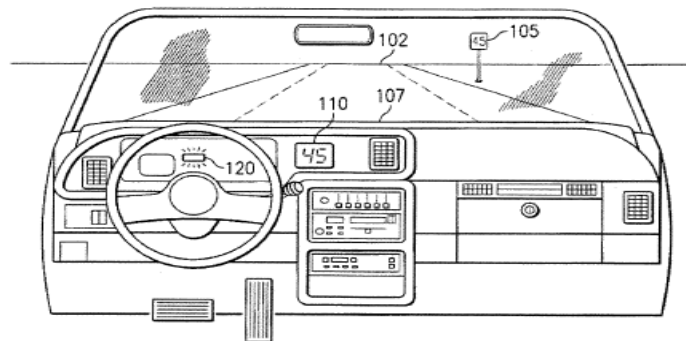

FIG. 1

Figure 1 illustrates a display 110, separate and remote from the speedometer, which shows the speed limit. Display 110 showing the speed limit is located at a substantial distance from the speedometer, which is located at a conventional location within the dashboard of the vehicle. “Integrally attached” would require the speedometer and the display 110 to be combined physically as one unit, without each losing its own separate identity, thus providing a distinction from Awada’s arrangement. It is not necessary to read into the claims an “integral display” to provide such a distinction, and converting “integrally attached” to “integral display” would read out of the claims the plain and ordinary meaning of “attached.”

Expert testimony

We also have considered Cuozzo’s argument that the disclosure in the ’074 Patent as filed would teach one with ordinary skill in the art to combine the speedometer readout with speed limit information on the colored display, resulting in an electronic embodiment making use of a common LCD (liquid crystal display) shared by the speedometer and the colored display. Cuozzo states:

Prof. Morris explained how these disclosures, in his opinion, would teach one of skill in the art “to combine the speedometer readout with the speed limit information on the LCD.” Morris Decl., Exhibit 2002 to Paper 21, at ¶¶ 27-29. The resulting electronic embodiment would have a common LCD component shared by the speedometer and colored display.

PO Resp. 5:12-17.

Cuozzo’s argument and the supporting testimony of Prof. Morris are unpersuasive.

Prof. Morris states: “It is my opinion that it would be natural for one skilled in the art at the time of the invention to combine the speedometer readout with the

speed limit information on the LCD.” Ex. 2002 ¶ 28. Prof. Morris further states: “It is my opinion that the mention of an LCD in confirmed claims 12 and 18 and col. 3, lines 4-6 and col. 6, lines 10-14 of the ’074 [Patent] implies that there is an electronic embodiment to one skilled in the art at the time of the invention.”

Ex. 2002 ¶ 29.

The language of Prof. Morris’s statements is vague. It is uncertain just how much is deemed to be described by the disclosure itself, and how much is filled-in or completed by one with ordinary skill in the art, who possesses ordinary creativity and is not an automaton. *KSR Int’l Co. v. Teleflex Inc.*, 550 U.S. 398, 421 (2007). What would have been obvious to one with ordinary skill in the art does not establish what actually is described in the specification. *Lockwood v. Am. Airlines, Inc.*, 107 F.3d 1565, 1572 (Fed. Cir. 1997). In any event, even assuming that such an embodiment is deemed to have been disclosed, the specification explains inadequately why such an embodiment would be covered by the claim language at issue, i.e., “integrally attached” as applied to the speedometer and a colored display.

Furthermore, it is undisputed that an electronic embodiment is disclosed in the specification, just not an electronic embodiment that makes use of the same liquid crystal display to show current speed readings of the speedometer and delineations of which speed readings are in violation of the speed limit at the present location of the vehicle. Prof. Morris’s testimony refers broadly to an electronic embodiment, not specifically to an electronic embodiment that makes use of a common liquid crystal display for showing speed readings and delineations of which speed readings are in violation of the speed limit.

Even assuming that an electronic embodiment of the right type is deemed to have been disclosed, it is explained inadequately why such an embodiment would

be covered by the claim language at issue, i.e., “integrally attached” as applied to the speedometer and a colored display.

We find the following testimony of Prof. Morris, on cross-examination, meaningful and instructive (emphasis in original):

Q But the claims never specifically recite that the speedometer and the colored display are implemented on the same LCD; right?

MR. CONNOR: Objection to form.

A I never saw that specific thing said, that they should be, said they should be integrated. The amendment said that they were integrally attached or the important feature was that they were integrated in the same place, but I never saw the specific words put all these on the same LCD display.

Ex. 1021, 11:41:2-12. Thus, even Cuozzo’s own expert, Prof. Morris, recognizes a distinction between (1) a speedometer that is “integrally attached” to a colored display, and (2) an integrated or integral electronic display using a single liquid crystal display. The former is what is claimed, not the latter.

Consistent with the Board’s claim construction, Prof. Morris states that it would be “uncommon” to refer to two things displayed on a common display as attached. Ex. 1021, 18:69:2-6. Prof. Morris additionally states that he would not use the term “attached” to refer to the relationship between two items that are graphically displayed on the same display. Ex. 1021, 18:70:23-18:71:2.

Prof. Morris further states: “It is further my opinion that the Amendment [Ex. 1013 discussed previously] provides a reasonable basis for finding that the inventor added the term ‘integrally’ to claim 10 to limit the attachment to an integrated display that displays the speed and speed limit in the same location.” Ex. 2002 ¶ 32. The language used by Prof. Morris actually comports more with the Board’s construction of “integrally attached,” not Cuozzo’s construction.

Prof. Morris refers to displaying speed and speed limit “in the same location,” which is not the same as using the same liquid crystal display to show speed and speed limit. We decline to equate one to the other.

District Court Interpretations

Cuozzo argues that its construction of “integrally attached” is supported by a U.S. District Court’s construction of “integrally connecting” in *Safety Rail Source, LLC v. Bilco Co.*, 656 F.Supp.2d 468 (D.N.J. 2009). PO Resp. 8:16-18.

According to Cuozzo, the District Court concluded that “integrally connecting” requires the connected pieces be joined to make up a single complete piece or unit, such that the connection becomes part of the single complete unit. PO Resp. 9:5-8.

Cuozzo also cites to *Sci. Specialties Inc. v. Thermo Fisher Sci. Inc.*, 684 F.Supp.2d 1187, 1191-1193 (N.D. Cal. 2010), for its determination that “integral and integrally must mean something more than contiguous.” PO Resp. 9, n.3.

The Board’s construction of “integrally attached” in this case is not at odds with the District Court’s construction of “integrally connecting” in *Safety Rail Source, LLC*. According to Cuozzo, the District Court stated that weight must be given to “integrally.” PO Resp. 8:18-20. The Board has given due weight to “integrally” as a modifier to “attached.” The two parts must be physically joined together as one unit.

Cuozzo’s arguments are unpersuasive. The terms at issue are different. “Attached” is not the same as “connecting.” “Integrally attached” is not the same as “integrally connecting.” The involved patents all have different disclosures. The field of invention and the level of ordinary skill in the art have not been shown to be the same for all cases. The arguments presented by the parties and the expert testimony on the issue have not been shown to be the same for all cases. Each case

must be decided on its own facts. Also, Cuozzo presents the terms at issue out of context, without the preceding and succeeding text in the involved claim or claims. There is not an adequate basis to make a proper comparison. Furthermore, district courts do not apply the rule of broadest reasonable interpretation for construing claim terms. Additionally, in the Board’s construction, “integrally” has a significance that is more than just “contiguous.”

Doctrine of Claim Differentiation

Cuozzo argues that the doctrine of claim differentiation supports its claim construction. PO Resp. 9-13. The argument is without merit.

An independent claim is presumed to be broader than a claim dependent thereon. Under the doctrine of claim differentiation, when a dependent claim adds a limitation relative to the independent claim on which it depends, there is a rebuttable presumption that the independent claim does not require that limitation. *Bancorp Servs. L.L.C. v. Sun Life Assur. Co. of Can.*, 687 F.3d 1266, 1275 (Fed. Cir. 2012); *Phillips v. AWH Corp.*, 415 F.3d 1303, 1315 (Fed. Cir. 2005). Cuozzo provides a diagram, reproduced below (PO Resp. 11):

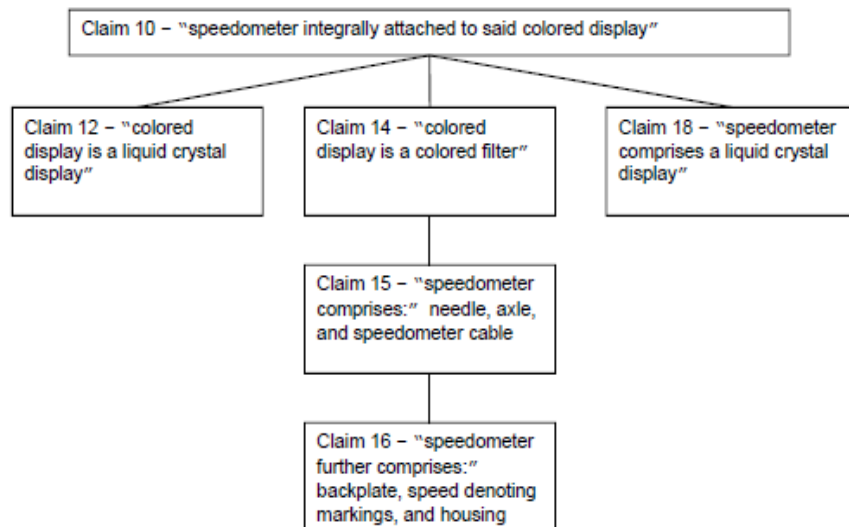

The diagram illustrates the relationship between certain claims. We agree with Cuozzo's assertion that because each of dependent claims 12 and 18 additionally recites a liquid crystal display relative to independent claim 10, independent claim 10 is presumed not to require that liquid crystal display and, thus, may read on a mechanical embodiment. We also agree with Cuozzo's assertion that because each of dependent claims 14-16 additionally recites mechanical components for the colored display or the speedometer, independent claim 10 is presumed not to require those mechanical components and, thus, also may read on an electronic embodiment employing a liquid crystal display. It reasonably is not disputable, and has not been disputed by Garmin, that independent claim 10 reads on a mechanical embodiment as well as an electronic embodiment having at least one liquid crystal display, which either is the colored display (claim 12) or is comprised within the speedometer (claim 18).

The rest of Cuozzo's application of the doctrine of claim differentiation, however, is misplaced, as explained below, even though Cuozzo correctly notes that dependent claim 12 adds the feature that said colored display of claim 10 is a liquid crystal display, and that dependent claim 18 adds the feature that the speedometer of claim 10 comprises a liquid crystal display. PO Resp. 12:5-7.

Cuozzo contends that neither claim 12 nor claim 18, presumably via the respective feature added thereby, requires the speedometer's liquid crystal display to be separate from the colored display's liquid crystal display. PO Resp. 12:7-8. On that basis, Cuozzo asserts that claim 18 encompasses a single electronic display that itself operates as a speedometer, or at least the display portion of a speedometer, and a colored display. PO Resp. 12:15-17. Therefore, Cuozzo argues that because independent claim 10 is presumed to be broader than dependent claim 18, claim 10 also must not require the liquid crystal display of the

speedometer and the liquid crystal display of the colored display to be separate. PO Resp. 12:18 to 13:2. Cuozzo thus reasons that the “integrally attached” feature of independent claim 10 “must encompass a single electronic display that itself operates as a speedometer (or at least display portion of a speedometer) and a colored display.” PO Resp. 13:3-7.

To the extent that it can be understood, we rephrase, more clearly, the reasoning of Cuozzo as follows:

Because a feature added by dependent claim 12 or by dependent claim 18 does not include a requirement that the liquid crystal display of the speedometer (claim 18) and the liquid crystal display that is the colored display (claim 12) are separate liquid crystal displays, independent claim 10 also must not have that requirement. Thus, claim 10 must read on a single electronic display that operates as the speedometer display and as the colored display.

The doctrine of claim differentiation does not stand for the proposition that if a dependent claim does not add a certain limitation by further recitation, then the independent claim on which it depends is presumed to be without that limitation. The failure of a dependent claim to add a requirement in its recitations relative to an independent claim on which it depends cannot negate or nullify a limitation that is already in the independent claim. The doctrine of claim differentiation cannot broaden claims beyond their correct scope, determined in light of the specification and the prosecution history and any relevant extrinsic evidence. *Multiform Desiccants, Inc. v. Medzam, Ltd.*, 133 F.3d 1473, 1480 (Fed. Cir. 1998).

A correct application of the doctrine of claim differentiation supports the Board’s claim construction. Claim 13 indirectly depends on claim 10 through claim 12, and claim 13 specifies that the display controller adjusts the liquid crystal display independently of the speedometer. Claim 17 indirectly depends on claim 10 through claim 14, and claim 17 specifies that the display controller rotates the

colored filter independently of the speedometer. Such a claim structure means claim 10 must be sufficiently broad to cover the case in which the speedometer and the colored display retain their separate identities and are independently operable. Claim 10 cannot require a single integral display.

B. Antedating Aumayer and Awada

Aumayer has an effective filing date of October 19, 2000. Awada has an effective filing date of March 8, 2001. Both Aumayer and Awada qualify as prior art under 35 U.S.C. § 102(e)(2), because the effective filing date of each is earlier than the effective filing date of the '074 Patent.

Cuozzo has sought to disqualify Aumayer and Awada as prior art, by demonstrating a date of invention prior to the effective filing date of the references, because 35 U.S.C. § 102(e)(2) requires a prior art patent to have been filed “before the invention by the applicant for patent.” *See, e.g., Loral Fairchild Corp. v. Matsushita Elec.*, 266 F.3d 1358, 1362 (Fed. Cir. 2001); *Mahurkar v. C.R. Bard, Inc.*, 79 F.3d 1572, 1577 (Fed. Cir. 1996). Priority of invention goes to the first party to reduce to practice unless the other party can show that it was the first to conceive the invention and that it exercised reasonable diligence in later reducing that invention to practice. *Brown v. Barbacid*, 276 F.3d 1327, 1337 (Fed. Cir. 2002); *Cooper v. Goldfarb*, 154 F.3d 1321, 1327 (Fed. Cir. 1998); *Mahurkar*, 79 F.3d at 1577.

Conception

An inventor’s testimony, standing alone, is insufficient to prove conception, as some form of corroboration is required. *Mahurkar*, 79 F.3d at 1577; *Price v. Symsek*, 988 F.2d 1187, 1194 (Fed. Cir. 1993). A rule of reason applies to determine whether the inventor’s testimony has been corroborated. *Price*, 988 F.2d at 1194. The requirement for corroboration of inventor’s testimony arose

out of a concern that inventors testifying at trial would be tempted to remember facts favorable to their case by the lure of protecting their patent or defeating another's patent. *Mahurkar*, 79 F.3d at 1577.

Cuozzo's inventor, Giuseppe A. Cuozzo, states in his declaration (Ex. 3001, ¶¶ 8-9) that on November 28, 1999, he was pulled over and ticketed by a police officer for speeding, and that while the officer was writing the ticket:

I [Giuseppe A. Cuozzo] came up with the idea of using GPS technology combined with instrumentation for displaying a speed limit and its relation to vehicle speed in a manner that would alert a driver as to whether he or she was speeding without requiring the driver to refer to roadside speed limit signs.

The above-noted testimony of the inventor lacks corroboration. The driving record of the inventor, submitted as Exhibit B of Exhibit 3001, corroborates only that the inventor received a speeding ticket on November 28, 1999, not anything that Giuseppe A. Cuozzo conceived on that day. In that regard, there is only what the inventor himself states he conceived on that day.

Furthermore, Cuozzo has not explained adequately how the above-quoted idea properly accounts for (1) a colored display and adjustments of the colored display, as are recited in independent claim 10 and carried into dependent claims 14 and 17, (2) a colored filter as is recited in claim 14, and (3) a display controller that rotates the colored filter independently of the speedometer to update continuously the delineation of which speed readings are in violation of the speed limit at the vehicle's present location.

Accordingly, Cuozzo has not established that Giuseppe A. Cuozzo conceived of the invention of claims 10, 14, or 17, as of November 28, 1999.

Cuozzo also submitted the inventor's written disclosure to the Invention Submission Corporation, Exhibit E of Exhibit 3001, titled "Disclosure To ISC And

Record Of Invention,” to show conception. Garmin does not dispute the sufficiency of the content of that disclosure for showing conception of the subject matter of claims 10, 14, and 17, and we are satisfied with the sufficiency of its technical content. In that regard, for purposes of antedating a prior art reference, the evidence of prior invention may be sufficient if it demonstrates obviousness of the claimed invention. *E.g., In re Spiller*, 500 F.2d 1170, 1178 (CCPA 1974); *In re Stryker*, 435 F.2d 1340, 1341 (CCPA 1971).

However, the date of that invention disclosure needs corroboration other than the inventor’s own representation. The disclosure document is a form including a series of questions with spaces filled-in by answers in handwriting presumably by the inventor Giuseppe A. Cuzzo, and the date of the document is partially filled-in by handwriting as “30th” day of “OCTOBER” 20“00.” Exhibit E of Exhibit 3001. We recognize that our reviewing court has set forth clearly that corroboration is not required when a party seeks to prove conception through the use of physical exhibits. *Mahurkar*, 79 F.3d at 1577. But that principle is directed to the technical content of a document, not to the date or origin of the document.

The law requires sufficient proof for the date and identity of a physical exhibit offered to show conception. In that regard, the Federal Circuit stated “[t]his rule is not new to patent law” and observed:

[C]onception by an inventor, for the purpose of establishing priority, **can not be proved by his mere allegation nor by his unsupported testimony where there has been no disclosure** to others or embodiment of the invention in some clearly perceptible form, such as drawings or model, **with sufficient proof of identity in point of time**. For otherwise[,] such facile means of establishing priority of invention would, in many cases, offer great temptation to perjury, and would have the effect of virtually precluding the adverse party from the possibility of rebutting such evidence. Hence it has been ruled in many cases that the mere unsupported evidence of the alleged

inventor, on an issue of priority, as to . . . conception and the time thereof, can not be received as sufficient proof of . . . prior conception.

Price v. Symsek, 988 F.2d at 1194-95 (emphases added) (citations omitted).

The signature of a witness appears on the front page of the invention disclosure document, at a location just below the filled-in date of October 30, 2000. If the signature is authenticated by testimony of the witness, it would serve as effective corroboration that the document existed on October 30, 2000. However, Cuozzo offered no testimony from the witness and has not indicated the identity of the witness who presumably witnessed the document on October 30, 2000. Cuozzo also has not represented, much less established, that the copy of the invention disclosure document was obtained from files that have been maintained regularly or continuously as a routine business record, which may serve as circumstantial evidence of corroboration under a rule of reason analysis.

On this record, and under a rule of reason analysis, the earliest date of conception we accord Cuozzo is December 8, 2000. The record includes a letter from a patent attorney to the inventor, Exhibit H of Exhibit 3001, dated December 8, 2000, which refers to the inventor's "Disclosure to ISC and Record of Invention." A pertinent part of that letter is reproduced below (emphasis in original):

You authorized ISC to provide us with information we require and have authorized us to provide ISC with information concerning the work we are performing on your behalf. We have received from ISC your "**Disclosure to ISC and Record of Invention**" and other materials relating to your invention and your relationship with ISC. We will immediately commence the preliminary patentability search.

Corroboration can be by independent circumstantial evidence. *Lacotte v. Thomas*, 758 F.2d 611, 613 (Fed. Cir. 1985). The source and content of the letter

constitutes sufficient independent circumstantial evidence to corroborate the existence of inventor's "Disclosure To ISC and Record of Invention" that is Exhibit E of Exhibit 3001, as of December 8, 2000.

Reasonable Diligence

We now turn to the issue of reasonable diligence toward reduction to practice. During the period in which reasonable diligence must be shown, there must be continuous exercise of reasonable diligence. *In re McIntosh*, 230 F.2d 615, 619 (CCPA 1956); *see also Burns v. Curtis*, 172 F.2d 588, 591 (CCPA 1949) (referring to "reasonably continuous activity"). A party alleging diligence must account for the entire critical period. *Griffith v. Kanamuru*, 816 F.2d 624, 626 (Fed. Cir. 1987); *Gould v. Schawlow*, 363 F.2d 908, 919 (CCPA 1966).

Even a short period of unexplained inactivity is sufficient to defeat a claim of diligence. *Morway v. Bondi*, 203 F.2d 742, 749 (CCPA 1953); *Ireland v. Smith*, 97 F.2d 95, 99-100 (CCPA 1938). In *In re Mulder*, 716 F.2d 1542, 1542-46 (Fed. Cir. 1983), the Federal Circuit affirmed a determination of lack of reasonable diligence, where the evidence of record was lacking for a two-day critical period. Likewise, in *Rieser v. Williams*, 255 F.2d 419, 424 (CCPA 1958), there was no diligence where no activity was shown during the first 13 days of the critical period.

A party alleging diligence must provide corroboration with evidence that is specific both as to facts and dates. *Gould v. Schawlow*, 363 F.2d at 920; *Kendall v. Searles*, 173 F.2d 986, 993 (CCPA 1949). The rule of reason does not dispense with the need for corroboration of diligence that is specific as to dates and facts. *Gould*, 363 F.2d at 920; *Kendall*, 173 F.2d at 993; *see also Coleman v. Dines*, 754 F.2d 353, 360 (Fed. Cir. 1985).

The record shows two extended periods of little activity, which have not been explained adequately. The first is approximately a two-month period extending from January 2001 to March 2, 2001, and the second is approximately a five-month period extending from March 10, 2001, to August 8, 2001. Both periods are subsequent to the effective filing date of Aumayer, and only the second period is subsequent to the effective filing date of Awada.

First Gap in Showing of Diligence

Inventor Mr. Cuozzo states in Paragraph 16 of his declaration, Exhibit 3001:

16. I received a preliminary report in January 2001 that identified several patents as potential prior art. I analyzed these patents and, on March 2, 2001, I sent my analysis to Monica Bealles, ISC Patent Services Coordinator, to forward to Mr. Kaardal [patent attorney], which she did on March 7, 2001. **Exhibit I** is a copy of my analysis, which I faxed to Ms. Bealles along with a copy of her forward to Mr. Kaardal.

The testimony is not specific as to when in January of 2001, Mr. Cuozzo received the preliminary report. On the issue of diligence, because Cuozzo would benefit with a later date of receipt of the preliminary report, we fairly can assume only the earliest day in January as the date of receipt of the report. *Cf., Haultain v. De Windt*, 254 F.2d 141, 142 (CCPA 1958) (Where testimony places a date to be proven within a time period, no date earlier than the last day has been proven.).

Cuozzo has not explained why it took as long as two months for the inventor to provide comments on the preliminary report, which identified several patents as potential prior art. Specific facts have not been provided for the circumstances and activities that occurred during those two months. For instance, it has not been indicated, even generally, on which days Mr. Cuozzo reviewed and prepared comments on the preliminary search report and why he did not do so on other days. We cannot conclude that during the two-month period from January 1, 2001, to

March 2, 2001, there was reasonably continuous activity toward reducing the invention to practice, sufficient to support a determination of reasonable diligence.

Second Gap in Showing of Diligence

Mr. Cuozzo explains that on March 10, 2001, he received yet another “Preliminary Patentability Search Report” stating that “utility patent protection could potentially be obtainable for your invention.” Ex. 3001 ¶ 17. Mr. Cuozzo explains that in light of the “good news” that his invention was potentially patentable, he then discussed the patent application process with ISC, and was informed that patenting referral services could not begin until he paid a minimum of \$ 3,500 to ISC, and that the total cost was \$ 9,945. Ex. 3001 ¶ 18. Mr. Cuozzo states that on August 8, 2001, he delivered a cashier’s check to ISC for \$ 9,545 and also paid the balance of \$ 400 in cash. Ex. 3001 ¶ 19. Thus, approximately five months passed between the time when Mr. Cuozzo received notice, on March 10, 2001, in a patentability search report that a utility patent was potentially obtainable for his invention, to the time when Mr. Cuozzo commenced the patenting process with ISC on August 8, 2001, by paying the advance fee that was required by ISC.

To explain the extended duration of that time, Mr. Cuozzo stated in Paragraph 19 of his declaration, Exhibit 3001:

The cost of the ISC Submission Agreement and patent services presented a significant financial obstacle to me, as I had insufficient income and financing through ISC was not an option. My only option was to use money that was in a trust account set up by my parents when I was a child. Gathering that money from the trust account and convincing my parents that I needed to do that took a few months.

The burden is on Cuozzo to show reasonable diligence covering the entirety of the approximately five-month critical period. The above-quoted testimony is not specific as to either dates or facts. The time of concern covers the period from

March 10, 2001, to August 8, 2001. The testimony indicates that the only obstacle standing in the way of commencing the patenting process was a minimum advance payment of \$ 3,500, even though the entire cost would be \$ 9,945, and that there was enough money in the trust account to cover the entire cost.

It is not clear, however, whether Mr. Cuozzo had authority to draw from the trust account or must obtain approval from his parents. While the Patent Owner Response states, on page 21, that the trust account was not accessible to Mr. Cuozzo, and cites to Paragraph 19 of Mr. Cuozzo's declaration, the testimony from Paragraph 19 of the declaration does not so indicate. On cross-examination, Mr. Cuozzo indicated that his parents exercised no control over the amount and frequency of payments from the trust account, which were fixed, and that he actually borrowed the money directly from his parents and then paid them back with money from his trust account when it was paid to him. Ex. 1024, 2-4.

Whether it is obtaining approval from parents to withdraw money from his trust account, or borrowing money from his parents to be paid back by future payments from his trust account, the declaration of Mr. Cuozzo does not present sufficient facts and dates for the approximately five-month critical period. The issue here lies with insufficiency of proof, and not with recognizing that efforts to obtain money to prepare and file a patent application do constitute qualifying activity. It is fund raising for purposes of commercial development, which does not constitute qualifying activity for diligence. *See, e.g., Scott v. Koyama*, 281 F.3d 1243, 1247-48 (Fed. Cir. 2002), *Griffith*, 816 F.2d at 627.

Additionally, Cuozzo has not made known what other efforts, if any, Mr. Cuozzo made during the approximately five-month period, to secure the necessary funding, or at least the \$ 3,500 required to initiate the patenting process. On cross-examination, Mr. Cuozzo stated that he did not try to borrow money from

anyone else. Ex. 1024, 4:106:11-13. The evidence does not support a conclusion that there was reasonably continuous activity in the approximately five-month period to secure funding to begin the patenting process, sufficient to support a determination of reasonable diligence from March 10, 2001, to August 8, 2001.

Cuozzo has not antedated successfully either Aumayer or Awada. At this stage in the proceeding, both Aumayer and Awada remain as applicable prior art against Cuozzo.

C. Claims 10, 14, and 17 as unpatentable
over Aumayer, Evans, and Wendt

Aumayer

Aumayer discloses a method for displaying vehicle speed. Ex. 1001, Abstract: 1-5. Also, it discloses displaying to the driver the speed limit at the current location of the vehicle, as it states: “In addition, speed limits at the current location may be displayed on the speed scale itself by highlighting an appropriate scale mark or producing a scale mark of a different length or color.” Ex. 1001, Abstract: 9-12. Aumayer further states that the current location of the vehicle may be determined by an on-board GPS. Ex. 1001, Abstract: 12-13.

Aumayer discloses that the speed limit at the current location of the vehicle is retrieved from a data storage media according to the current location. Ex. 1001, Abstract: 13-15, 4:45-53. Aumayer discloses an electronic embodiment of its invention, which makes use of a liquid crystal display, a plasma screen, or a cathode ray tube. Ex. 1001, 7:34-37. Figure 2d of Aumayer is reproduced below:

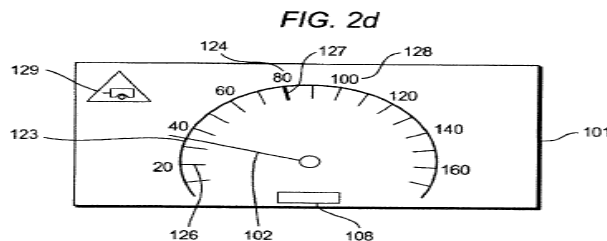

Figure 2d illustrates an embodiment of Aumayer's electronic display. Aumayer describes that the determined speed limit of 80 km/hr for the vehicle's current location is shown by the speed scale value 124 and speed scale mark 127 at the speed limit, both of which are highlighted or emphasized such as by use of color different from that used for the remainder of the display device, by enlargement, and/or by widening, on the electronic display. Ex. 1001, 6:21-27. Aumayer states expressly that the speed limit is highlighted or emphasized by the scale mark 127. Ex. 1001, 6:33-35.

Aumayer discloses continuously updating the applicable speed limit, based on the vehicle's current location. It states (Ex. 1001, 2:36-42):

It is especially advantageous if an acoustic and/or optical warning signal is produced when the display of the actual vehicle speed and/or the speed limits or maximum allowed speed value changes. The user of the vehicle is thus signaled that he should now consider another speed limit and/or other physical units being used in the region in which the vehicle is now currently located.

Aumayer also discloses updating the stored speed limit data in the vehicle by a radio connection or a data carrier, as it recognizes that maximum speed values may change and desires to display "the correct speed limits." Ex. 1001, 2:57-61.

Aumayer further states that "it is also possible to use a commercial combined apparatus with mechanical display elements for the display device **211**." Ex. 1001, 7:42-44. Specific details of that mechanical embodiment are not described. However, Aumayer states that, for example, "a speed limit can be made visible by background lighting in a different color at the scale mark associated with the corresponding speed limit." Ex. 1001, 7:48-51.

As discussed above, Aumayer describes every feature of claim 10, except for the requirement that the speedometer is "integrally attached" to a colored display

that delineates which speed readings are in violation of the speed limit at the vehicle's present location. The single electronic display screen of Aumayer, showing both the image of a speedometer and a colored scale mark indicating the current speed limit, does not meet the claim recitation of a speedometer that is "integrally attached" to a colored display that delineates which speed readings are in violation of the speed limit at the vehicle's present location. The speedometer and the colored display are not discrete components joined to each other with each retaining its own separate identity.

Aumayer states that "it is also possible to use a commercial combined apparatus with mechanical display elements for the display device **211**." Ex. 1001, 7:42-44. Aumayer also states that "a speed limit can be made visible by background lighting in a different color at the scale mark associated with the corresponding speed limit." Ex. 1001, 7:48-51. But none of that indicates that a colored display necessarily is attached integrally to the speedometer.

Evans

Evans discloses a combined vehicle speedometer and speed warning indicator. Ex. 1009, 1:68 to 2:23. The speed warning indicator is installed on the speedometer cover. Ex. 1009, 2:16-17. It comprises a transparent plate attached to the front cover of the speedometer. Ex. 1009, 2:1-3. Evans describes the speed warning indicator as follows, Ex. 1009, 2:3-8 (emphasis added):

The plate bears **warning indicia**, for example, **a special color and/or a plurality of marks, spaces, ridges, etc.** so that when the speedometer dial is viewed through it, a portion of the dial representing speeds in excess of a predetermined limit are demarked by the warning indicia.

Evans describes that a driver can tell what speeds are under or in excess of the speed limit by making a swift reference to the speedometer through the

indicator and seeing whether the speedometer needle is in or out of the warning area on the indicator plate. Ex. 1009, 2:9-13. Evans further describes that the indicator plate can be made adjustable for changes in the speed limit. Ex. 1009, 2:18-19. As shown in Figure 3, reproduced below, the red colored plate 12 is positioned on speed dial 30 so that only the portion of the dial that contains numbers representing speeds in excess of the speed limit is overlaid by the plate:

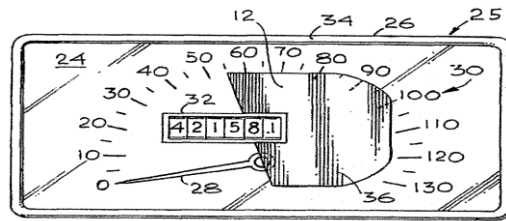

Fig. 3

Figure 3 illustrates the speedometer display and colored plate combination of Evans. The colored plate 12 of Evans is a fixed structure integrally attached to the speedometer. Although the plate may be removed and replaced, in its operational state it is a fixed, non-moveable, and non-adjustable structure. In that respect, Evans states, Ex. 1009, 3:37-44:

It will be understood that plate **12** can, if desired, be removed from cover **24** and either another similar plate of different configuration can be substituted or plate **12** can be recut and repositioned or merely repositioned on cover **24** so as to extend over another range of speed numbers on dial **30**. For example this would be desirable in the event that the 55 mph current speed limit were abolished.

Wendt

Wendt's invention relates to an automobile speed limit indicator adapted to be used "upon the speedometer of any automobile by being readily attached and adjusted at all times to indicate the proper speed limit by means of a pointer." Ex. 1011, 1:15-20. The speed limit indicator is attachable by a suction cup to the

glass cover of a speedometer, and includes a moveable pointer preferably provided with a handle or a knob. Ex. 1011, 2:30-41; 3:12-16. Figure 4 is shown below:

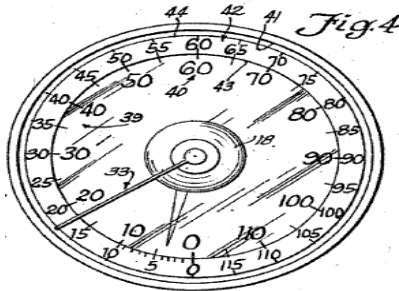

Figure 4 illustrates a front plan view of the speed limit indicator already attached to the glass cover of a speedometer. Wendt describes that when the vehicle operator observes that the speed limit is 20, he turns the pointer 16 to the speedometer indication 20, and that if the speed limit changes to 25, 30, or 35, or whatever it may be, the driver again should adjust the pointer by rotating the knob 17. Ex. 1011, 3:17-25.

The Obviousness Reasoning

In an obviousness analysis, it is not necessary to find precise teachings in the prior art directed to the specific subject matter claimed because inferences and creative steps that a person of ordinary skill in the art would employ can be taken into account. *See KSR Int'l Co.*, 550 U.S. at 418. A basis to combine teachings need not be stated expressly in any prior art reference. *In re Kahn*, 441 F.3d 977, 987-88 (Fed. Cir. 2006). There need only be an articulated reasoning with rational underpinnings to support a motivation to combine teachings. *Id.* at 988. Also, the level of ordinary skill in the art usually is evidenced by the references themselves. *See Okajima v. Bourdeau*, 261 F.3d 1350, 1355 (Fed. Cir. 2001); *In re GPAC Inc.*, 57 F.3d 1573, 1579 (Fed. Cir. 1995); *In re Oelrich*, 579 F.2d 86, 91 (CCPA 1978).

As discussed above, Evans describes a colored plate for indicating the speed limit, which plate is attached integrally to the speedometer in a fixed position but

replaceable by a plate having a different shape to reflect a different speed limit. Also as discussed above, Wendt describes use of a rotatable pointer for indicating the applicable speed limit dynamically. Such disclosures of Evans and Wendt logically would have suggested to one with ordinary skill in the art that the colored plate of Evans can be made dynamically-adjustable by the driver.

In light of Aumayer's electronic speed limit indicator, which makes use of a GPS receiver to determine a vehicle's current location, and which then makes use of the determined location to look up the applicable speed limit at that location for display, one with ordinary skill in the art would have known to apply the same automated approach to the manually-adjustable colored plate suggested by Evans and Wendt. One with ordinary skill possesses ordinary creativity and is not an automaton. *KSR Int'l Co.*, 550 U.S. at 421. In that connection, one with ordinary skill would have recognized and appreciated that the manually-adjustable colored plate of Evans and Wendt can be improved by adding automatic control if the dynamic settings are automatically determinable, as in the case of Aumayer's device. *See, e.g., Leapfrog Enters., Inc. v. Fisher-Price, Inc.*, 485 F.3d 1157, 1161-62 (Fed. Cir. 2007). Cuozzo does not argue that one with ordinary skill in the art would not have known how to implement the automatic control on the manually-adjustable colored plate of Evans and Wendt.

Cuozzo argues that Aumayer does not disclose updating continuously the delineation of which speed limit readings are in violation of the speed limit at a vehicle's present location, as is recited in claim 10, because, according to Cuozzo, the speed limit discussed in Aumayer "is a speed limit for a certain class of road in a given region and is not based on the 'vehicle's present location.'" PO Resp. 25:1-5. Cuozzo notes that one with ordinary skill would not consider a region, such as a state, country, or city, as a vehicle's present location. PO Resp. 25:9-11.

The argument is misplaced. Based on facts determined above with regard to Aumayer, it is indisputable that Aumayer displays the speed limit for the current location of a vehicle as determined by a GPS receiver, and not merely the speed limit for a certain class of road in a given region without any connection to the vehicle's current location. Cuozzo does not address, meaningfully, the portions of Aumayer identified and discussed above. Rather, Cuozzo focuses on the manner in which Aumayer obtains the speed limit for the present location of the vehicle.

Cuozzo has identified nothing in the claims that precludes a system from first dividing all possible locations into regions and class of roads within each region, then storing speed limit information based on such organization, and then looking up the applicable speed limit based on a vehicle's current location as determined by a GPS receiver and where that current location falls within the classification. Aumayer discloses that a region is an area having the same speed limit for the same type of streets or roads. Ex. 1001, 8:1-6. Aumayer also discloses that as a vehicle travels from one class of street or road to another, the speed limit display will be changed to reflect any change in the applicable speed limit. Ex. 1001, 5:2-5; 5:63; 2:57-59. It is inconsequential that Aumayer obtains the speed limit for a vehicle's present location by accessing a database, which is organized by regions and class of roads within each region. The updating is as continuous as it needs to be to indicate the speed limit at the current location.

Furthermore, Cuozzo has articulated no purpose, let alone any benefit noted in the disclosure of Aumayer, for displaying to the driver of a vehicle the speed limit of any class of road in any region, when the vehicle is not presently on that class of road in that region. That is not the invention or the disclosure of Aumayer.

Cuozzo argues that one with ordinary skill in the art would not have combined the dynamic, continuously controlled display system of Aumayer with

the immovable color plate 12 of Evans or the manually rotated pointer 16 and rubber suction cup unit of Wendt. PO Resp. 27:6-10. The argument is without merit. The reasoning for arriving at the invention of claim 10, based on the collective teachings of Aumayer, Evans, and Wendt, is articulated and explained above and is not undermined by Cuozzo's argument. As discussed above, one with ordinary skill would have recognized that the dynamically-adjustable colored plate suggested by Evans and Wendt can be improved by adding automatic control, if the dynamic settings are automatically-determinable.

Teaching Away Argument

Cuozzo further argues that all three of Aumayer, Evans, and Wendt teach away from a combination of Aumayer, Evans, and Wendt. The argument is not supported by the respective reference disclosures.

To constitute properly a "teaching away," the teaching must be evaluated from a technological perspective, not merely a comparative perspective. For instance, it is not a "teaching away" of significance unless one with ordinary skill in the art would have understood the teaching as conveying that the method or structural configuration at issue reasonably cannot be expected to achieve what it is required to achieve according to the claimed invention. *See, e.g., Syntex (U.S.A) LLC v. Apotex, Inc.*, 407 F.3d 1371, 1380 (Fed. Cir. 2005) ("Under the proper legal standard, a reference will teach away when it suggests that the developments flowing from its disclosures are unlikely to produce the objective of the applicant's invention." (citing *In re Gurley*, 27 F.3d 551, 553 (Fed. Cir. 1994))).

A prior art reference must be considered for everything it teaches by way of technology and is not limited to the particular invention it is describing and attempting to protect. *EWP Corp. v. Reliance Universal Inc.*, 755 F.2d 898, 907 (Fed. Cir. 1985). The use of patents as references is not limited to what the

patentees describe as their own inventions or to the problems with which they are concerned, as they are a part of the literature and are relevant for all they contain. *In re Heck*, 699 F.2d 1331, 1333 (Fed. Cir. 1983) (citing *In re Lemelson*, 397 F.2d 1006, 1009 (CCPA 1968)).

There is no requirement that anything disclosed in a prior art reference, such as its stated purpose, goal, or objectives, must be preserved or further developed by every reliance on its teachings as prior art. All of the disclosures of a prior art reference, including non-preferred embodiments, must be considered. *In re Lamberti*, 545 F.2d 747, 750 (CCPA 1976); *see also In re Susi*, 440 F.2d 442, 446 n.3 (CCPA 1971) (one is not significantly “taught away” from a “particularly preferred embodiment” by the suggestion that something else may be even better).

According to *Cuozzo*, because *Aumayer* describes that its combined instrument (one device for use in multiple countries) “advantageously comprises a display screen so that the method according to the invention can be performed without mechanical or structural arrangements,” Ex. 1001, 2:49-53, it teaches away from combining with *Evans* and *Wendt*. PO Resp. 27:10-20. For reasons discussed above, the argument is without merit. A mechanical embodiment is not described as inoperative, just less advantageous or less preferred.

According to *Cuozzo*, *Evans* states that use of a speedometer of a special design “like the combined instrument in *Aumayer*” would be too expensive and unsuccessful. PO Resp. 28:9-17. That is simply incorrect. *Evans* was issued in 1976 and *Aumayer* in 2003. *Evans* could not have been referring specifically to the device of *Aumayer*. *Evans* does state that certain specialized speed limit indicator devices have been used in the past but not extensively or successfully. Ex. 1009, 1:46-52. That does not teach away from applying the transparent

colored plate of the combined teachings of Evans and Wendt to the glass cover of Aumayer's speed limit indicator.

Evans describes that prior speed limit indicators were expensive and invariably required disassembly of the vehicle speedometer or construction of a new speedometer to substitute for the one with which a vehicle initially is equipped. Ex. 1009, 1:46-52. That does not mean the preexisting speed limit indicators were inoperative or nonfunctional, and certainly not that Aumayer's speed limit indicator appearing 27 years later will be inoperative or nonfunctional, particularly if it is to incorporate the transparent colored plate according to the combined teachings of Evans and Wendt.

According to Cuozzo, the device of Wendt was meant to work with a mechanical speedometer. That is true, but it does not mean Wendt discloses that its device cannot work with a speedometer with an electronic display. It also does not mean that a combined device of Evans and Wendt will be inoperative, or nonfunctional, if applied to the glass cover of an electronic display.

Cuozzo argues that Wendt teaches away from an automatically adjusting speed limit display such as that disclosed by Aumayer, because Wendt discloses benefits for having the driver manually manipulate the mechanical pointer to adjust the speed limit indication. PO Resp. 29:3-10. The pertinent portion of Wendt is reproduced below (Ex. 1011, 5:8-15):

The present speed indicator, when used on a speedometer, will discipline the driver and cause him to look for and observe speed limit signs and then make a temporary record of the speed limit by moving the pointer to that point on the speedometer.

It will be a useful aid to the driver to prevent him from forgetting the speed limit and to remind him that the speedometer pointer must not pass the speed limit pointer.

The above-quoted text would not have conveyed to one with ordinary skill in the art that automatic updating of the speed limit display without driver participation cannot be accomplished or would be inoperative or nonfunctional. Rather, one with ordinary skill in the art would have recognized and appreciated that automatic updating of the speed limit display provides the driver of the vehicle a different kind of reminder, a visual reminder through the automatically updated display. Also, as discussed above, there is no requirement that in determining obviousness, every goal or objective of a prior art reference must be advanced when relying on any technical disclosure of the reference. The obviousness analysis is not an attempt to incorporate every feature of each reference. The value of a prior art reference is not limited to the particular invention it is describing and attempting to protect. *EWP Corp.*, 755 F.2d at 907.

All of Cuozzo's arguments alleging a "teaching away" of the combined teachings of Aumayer, Evans, and Wendt are without merit.

Claim 14 depends on claim 10, and claim 17 depends on claim 14. We are persuaded that claims 10, 14, and 17 would have been obvious over the combined teachings of Aumayer, Evans, and Wendt. With regard to claims 14 and 17, Cuozzo makes no argument separate from those it has raised with respect to claim 10 and already discussed above. With respect to claim 14, we note that the colored display according to the combined teachings of Evans and Wendt is a colored filter. With respect to claim 17, we note that the colored filter according to the combined teachings of Evans and Wendt would be rotated independently by a controller to update continuously the delineation of which speed readings are in violation of the speed limit at the vehicle's present location.

- D. Claims 10, 14, and 17 as unpatentable
over Tegethoff, Awada, Evans, and Wendt

Tegethoff

Tegethoff discloses an image display system for use on a vehicle, which includes an image screen and an image generating computer. Ex. 1003, 4:2:16-18. The image displayed on the screen imitates analog mechanical pointer instruments, and in image form cannot be distinguished from actual mechanical devices. Ex. 1003, 4:2:34-40.

Figure 2 of Tegethoff is reproduced below:

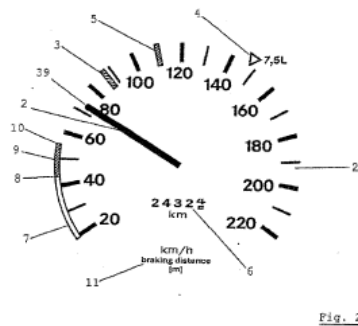

Figure 2 illustrates an image of Tegethoff's speedometer display. Ex. 1003, 5:2:30-32. On the image shown is a mark 5 for indicating the currently permissible maximum speed for the road section where the vehicle is located. Ex. 1003, 6:1:9-12. That maximum speed can be set according to an element for navigation and a database. Ex. 1003, 6:1:13-15. Tegethoff describes that the critical markings such as that showing the speed limit can be colored red. Ex. 1003, 7:1:38-45.

Awada

Awada discloses a method and apparatus for reporting the legal speed limit to the driver of a vehicle. Exhibit 1010, 1:36-38. Awada describes using a GPS receiver to determine the present location of the vehicle, and then using that

determined position as a search key in a database to retrieve speed limit for that location. Ex. 1010, 1:39-43. The retrieved speed limit then is reported to the driver. Ex. 1010, 1:43-44. Awada discloses that the database of speed limit information may be stored locally or stored in a remote location that is accessible by a wireless communication link. Ex. 1010, 1:39-47. Awada further discloses that in one embodiment a warning chime is played through a speaker or through the earpiece of the driver's cellular telephone, if the vehicle exceeds the speed limit. Ex. 1010, 1:50-55.

Figure 1 of Awada is reproduced below:

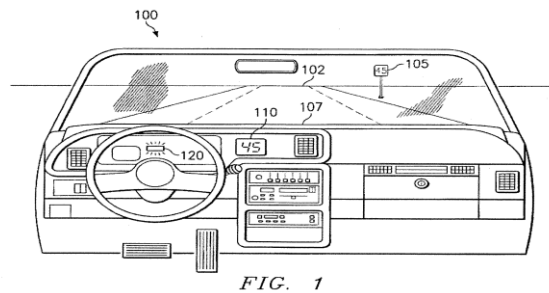

Figure 1 illustrates an embodiment of Awada's speed limit display. As is depicted in Figure 1, a vehicle is traveling on road 102, which has a posted legal speed limit 105, and mounted on the dashboard 107 of the vehicle is a display 110, which shows the driver the speed limit at the vehicle's current location. Ex. 1010, 2:24-30. Also mounted on the dashboard is a warning light 120, which indicates when the vehicle exceeds the speed limit. Ex. 1010, 2:30-31.

The Obviousness Reasoning

We first address a key argument advanced by Cuozzo, i.e., that the reference to "maximum permissible speed" in Tegethoff is not directed to the speed limit contemplated by the claimed invention, i.e., the legal speed limit. We agree with Cuozzo, that "speed limit" in claim 10 of the '074 Patent means the legal speed limit. However, a legislative speed limit is a legal speed limit.

Cuozzo notes that Tegethoff describes that the “maximum permissible speed” can be set in one of three ways: (1) manually by the driver, (2) “according to an element for navigation and a database with traffic control information,” and (3) “by an element for receiving transmitters outside the vehicle for traffic control.” PO Resp. 30:11-16. Cuozzo states that none of those ways suggests that the “maximum permissible speed” is the legal speed limit. PO Resp. 30:16-18.

Cuozzo’s argument is unpersuasive. It fails to address other language in the disclosure of Tegethoff. In particular, Tegethoff states, Ex. 1003, 7:1:38-48 (emphasis added):

With the markings shown above in the shape of marks or display bars, the coloring can also help quicker classification of information by the driver. Thus, for example, warnings that require immediate action or represent a critical technical or **legislative limit**, can appear in the color red (e.g., a **maximum speed** or the part of the breaking distance or stopping distance that exceeds the distance to the vehicle ahead).

In light of the above-quoted text referring to the “legislative limit” in the context of a “maximum speed,” one with ordinary skill in the art would have recognized that Tegethoff discloses the legislative speed limit as one form of implementation of what is referred to as “maximum permissible speed” in the disclosure of Tegethoff. At the very least, Tegethoff reasonably would have suggested the legislative speed limit as the “maximum permissible speed.”

Tegethoff is not sufficiently specific about how its system obtains the “maximum permissible speed,” for example, the legislative speed limit. Awada, however, discloses that the legal speed limit can be obtained by using a GPS receiver to obtain the present location of a vehicle, and then using that determined location to access a speed limit database to retrieve the speed limit at the vehicle’s current location. Ex. 1010, 1:39-43, 2:24-42.

In light of Tegethoff and Awada, one with ordinary skill in the art would have known to use the method disclosed in Awada to obtain the legal speed limit at the vehicle's current location and regard it as the "maximum permissible speed" in Tegethoff. Tegethoff even specifically mentions the use of "an element for navigation" for setting the maximum speed. Ex. 1003, 6:1:13-16.

As described above, Tegethoff and Awada collectively account for every feature of claim 10, except for the requirement that the speedometer is "integrally attached" to a colored display that delineates which speed readings are in violation of the speed limit at the vehicle's present location. The single electronic display screen of Tegethoff, showing both the image of a speedometer and a colored scale mark indicating the current speed limit, does not meet the claim recitation of a speedometer that is attached integrally to a colored display that delineates which speed readings are in violation of the speed limit at the vehicle's present location. As is the case with Aumayer, described above, the speedometer and the colored display are not discrete components joined to each other with each retaining its own identity. Rather, there is a single integral display, which performs the function of both the speedometer and colored display.

In light of the colored plate in Evans for indicating the speed limit, which plate is attached integrally to the speedometer in a fixed manner but replaceable by a plate having a different shape to reflect a different speed limit, and also the rotatable pointer of Wendt for indicating the applicable speed limit dynamically, one with ordinary skill in the art would have known to make Evans' colored plate manually-adjustable by the driver to reflect changes in speed limit dynamically.

Based on the combined teachings of Tegethoff and Awada with regard to a speed limit indicator that makes use of a GPS receiver to determine a vehicle's current location, and then makes use of the determined location to look up the

speed limit at that location for display, one with ordinary skill in the art would have known to apply an automated approach to the manually-adjustable colored plate of Evans and Wendt. One with ordinary skill would have recognized that the manually-adjustable colored plate of Evans and Wendt can be improved by adding automatic control provided by a GPS receiver and electronically stored speed limit values based on vehicle location, as is disclosed by Tegethoff and Awada. *See, e.g., Leapfrog Enters., Inc.*, 485 F.3d at 1161-62.

Cuozzo argues that Awada merely discusses reporting the speed limit to the driver and nowhere mentions displaying the speed of the vehicle to the driver, much less delineating which “speed readings” of the vehicle are in violation of the applicable speed limit. PO Resp. 32:1-13. The argument is misplaced, because Awada is relied on solely for its teachings of how to obtain the speed limit for the current location of the vehicle. One cannot show non-obviousness by attacking references individually where the grounds of unpatentability are based on combinations of references. *In re Merck*, 800 F.2d 1091, 1097 (Fed. Cir. 1986); *In re Keller*, 642 F.2d 413, 426 (CCPA 1981).

Cuozzo argues that neither Evans nor Wendt discloses or suggests the use of a display controller or a global positioning system receiver. PO Resp. 32:19 to 33:1. That argument equally is misplaced, as it is also premised on attacking the references individually when the ground of unpatentability is based on a combination of references. Evans and Wendt are not relied on for teaching or suggesting the use of a display controller or a global positioning system receiver. Cuozzo’s contention does not undermine the obviousness rationale based on the combined teachings of Tegethoff, Awada, Evans, and Wendt.

Cuozzo argues that one with ordinary skill would not have combined Awada’s dynamic speed limit display system with the immovable colored plate

12 of Evans. PO Resp. 34:10-13; 35:2-4. The argument again is misplaced, for attacking references individually cannot show non-obviousness where the ground of unpatentability is based on a combination of references. Evans and Wendt in combination suggest a manually-adjustable colored plate for indicating the speed limit. Cuozzo's reading of Evans as disclosing an "immovable" colored plate that is not combinable with "dynamic" aspects of Awada's system fails to consider the teachings of Evans and Wendt in collectively conveying an adjustable colored plate indicative of the speed limit.

Cuozzo further makes a number of "teaching away" arguments, all of which misapply the concept of "teaching away" in a similar manner as we have rejected its "teaching away" arguments in the context of Aumayer, Evans, and Wendt.

First, Cuozzo contends that both Tegethoff's and Wendt's manually-adjustable control teach away from a combination with Awada because the potential to set the alert at above the speed limit is contrary to Awada's goal of being alerted when the speed limit is exceeded. PO Resp. 33:14 to 34:2; 34:4-6; 34:19 to 35:5. The argument is without merit. Each of Tegethoff and Wendt is concerned with being alerted of the vehicle's exceeding the legal speed limit. A manual setting is just one implementation of Tegethoff. Other implementations rely on a navigation device and a database. Ex. 1003, 6:1:13-18.

Secondly, Cuozzo argues that Tegethoff and Awada teach away from mechanical speedometers like those used in Evans and Wendt. PO Resp. 35:6 to 36:7. Cuozzo refers to this language in Tegethoff (Ex. 1003, 2:2:33-40):

The object of the present invention is to create a display system that has the good readability of analog pointer instruments and, moreover, in an easily understandable manner provides additional information that facilitates the safe and economical operation of the vehicle. This object is attained with a display system.

Cuozzo also refers to this language in *Awada* (Ex. 1010, 1:17-20):

In such cases, it would be helpful if the driver were provided with a constant indication of the posted speed limit, as a display on the dashboard of an automobile, for instance.

Cuozzo's "teaching away" argument is misplaced. The fact that *Tegethoff* recognizes a benefit of an electronic display over a mechanical speedometer does not mean that elements designed for use with the latter, such as the manually-adjustable colored display of *Evans and Wendt*, have been indicated as unusable with a speedometer having an electronic display. Even though the device of *Evans and Wendt* is designed to work with a conventional mechanical speedometer, one with ordinary skill in the art would have recognized that the colored display of *Evans and Wendt* can be mounted to the glass cover of either a conventional mechanical speedometer or an electronic version of the same. With regard to the above-quoted statement in *Awada*, Cuozzo fails to point to credible evidence reasonably indicating that the colored display according to the combined teachings of *Evans and Wendt* cannot be put under automatic control.

In any event, as we already have discussed above, specific goals and advantages noted in a prior art reference need not always be preserved when relying on its technical teachings. A prior art reference must be considered for everything it teaches by way of technology and is not limited to the particular invention it is describing and attempting to protect. *EWP Corp.*, 755 F.2d at 907.

According to Cuozzo, *Evans* states that use of a speedometer of a special design "like the display system in *Tegethoff* and the automatic display system of *Awada* would be too expensive and unsuccessful." PO Resp. 36:7-9. That is simply incorrect. *Evans* issued in 1976; *Tegethoff* issued in 1998; and *Awada* issued in 2003. *Evans* could not have been referring specifically to the device of

Tegethoff or Awada. Evans does state that certain specialized speed limit indicator devices have been used in the past but not extensively or successfully. Ex. 1009, 1:46-52. It is not evident what that has to do with a teaching away from applying the transparent colored plate of Evans and Wendt to the glass cover of an electronic speed limit indicator of Tegethoff and Awada.

Evans describes that prior speed limit indicators were expensive and required disassembly of the speedometer or construction of a new speedometer. Ex. 1009, 1:46-52. That does not mean preexisting indicators were inoperative or nonfunctional, and certainly not that Tegethoff's or Awada's indicator appearing twenty-two and twenty-seven years later, respectively, will be inoperative or nonfunctional.

According to Cuozzo, the device of Wendt was meant to work in conjunction with a standard mechanical speedometer. However, that does not mean Wendt discloses that its device cannot work with a speedometer having an electronic display. It also does not mean that a combined device of Evans and Wendt will be inoperative, or nonfunctional, if applied to the glass cover of a speedometer with an electronic display.

Cuozzo argues that Wendt teaches away from automatically adjusting the speed limit display, because Wendt discloses benefits for having the driver manually manipulate the mechanical pointer. PO Resp. 37:1-8. We already have rejected that argument in the context of the obviousness ground over Aumayer, Evans, and Wendt. We note further that one with ordinary skill in the art would have recognized that automatic updating of the speed limit display provides the driver a different kind of reminder than that provided by physical manipulation.

Cuozzo's arguments alleging a "teaching away" from a combination of Aumayer, Evans, and Wendt that meets the claimed invention are unpersuasive.

We are persuaded that claims 10, 14, and 17 would have been obvious over Tegethoff, Awada, Evans, and Wendt. With regard to claims 14 and 17, Cuozzo makes no argument separate from those it has raised for claim 10.

E. Cuozzo's Motion to Amend Claims

Cuozzo filed a motion (Paper 32) to amend claims. Cuozzo seeks to replace claim 10 with substitute claim 21, claim 14 with substitute claim 22, and claim 17 with substitute claim 23. Claims 22 and 23 each depend on claim 21.

With respect to claim 10, substitute claim 21 adds:

wherein the speedometer comprises a liquid crystal display, and wherein the colored display is the liquid crystal display.

The above-noted addition represents more than just incorporating the limitations of original dependent claims 12 and 18 into independent claim 10, because claim 18 recited only that the speedometer comprises a liquid crystal display, not also that the colored display is that same liquid crystal display.

Also included within substitute claim 21 is this limitation pre-existing in claim 10: a speedometer integrally attached to said colored display.

Thus, as written in proposed substitute claim 21, the speedometer has to be “integrally attached” to a colored display, which is a liquid crystal display and which also is a component comprised within the speedometer itself.

Per 35 U.S.C. § 316(d)(3), a claim amendment in an *inter partes* review may not enlarge the scope of the claims of the patent or introduce new matter.

The Patent Owner has the burden to set forth written description support in the original disclosure for each added or amended claim. 37 C.F.R. § 42.121(b)(1). Given the proper construction of “integrally attached,” in the context of the original disclosure, Cuozzo has not shown that the original disclosure of the '074 Patent provides written description for this trifecta: (1) speedometer

comprises a liquid crystal display; (2) colored display is that liquid crystal display comprised by the speedometer; and (3) the speedometer is attached integrally to that colored display, which is the liquid crystal display comprised by the speedometer.

Cuozzo points to original patent claim 18 for describing “wherein the speedometer comprises a liquid crystal display.” Motion, at 7:3-8. It does. For each of the other two elements in the trifecta, both requiring the colored display to be “the” liquid crystal display comprised by the speedometer, Cuozzo merely points to the disclosure, which indicates that the colored display “is a liquid crystal display” (claim 12, emphasis added), “may take the form of a colored filter” (Ex. 3006, 3:3-6, emphasis added), and “could also take the form of a liquid crystal display” (Ex. 3006, 6:11-14, emphasis added). Motion (Paper 32) at 7:9-15. The showing is not commensurate in scope with what is claimed, i.e., that the colored display is the liquid crystal display comprised by the speedometer.

Cuozzo does not adequately explain how the evidence relied on describes the “integrally attached” requirement between the speedometer and the colored display where the colored display is the liquid crystal display comprised by the speedometer. In that regard, we note further the analysis contained in the claim construction section of this opinion, which concludes that the original disclosure of the ’074 Patent does not describe an embodiment using a single liquid crystal display to show the speed readings of a speedometer as well as the delineations of which speed readings violate the speed limit at the vehicle’s present location.

Cuozzo has failed to set forth how proposed substitute claims 21-23 satisfy the written description requirement of 35 U.S.C. § 112, first paragraph.

Substitute claims 21-23 also enlarge the scope of the respective original patent claims which they replace. As is pointed out by Garmin, a proper

construction of “a speedometer integrally attached to said colored display” in the context of original patent claims 10, 14, and 17, and as articulated by the Board, does not cover a speedometer and a colored display that is subsumed completely within the speedometer. Yet, that arrangement would be within the scope of substitute claim 21, as Cuozzo redefines the meaning of “integrally attached.” The scope of each of claims 10, 14, and 17 has been enlarged because a structure not covered by those claims would be covered by respective substitute claims 21-23.

F. Cuozzo’s Motion to Exclude Evidence

Cuozzo seeks to exclude certain testimony of Prof. James Morris. Motion (Paper 48), at 2:5-8. The motion is *dismissed* as moot, because we have not reached the merits of Garmin’s argument that relied on the testimony Cuozzo seeks to exclude, i.e., the argument that substitute claim 23 enlarges the scope of original patent claim 17, because claim 23 has been broadened to cover displaying a single speed reading in red once the speed reading exceeds the speed limit.

CONCLUSION

Garmin has met its burden of proof by a preponderance of the evidence in showing that claims 10, 14, and 17 of the ’074 Patent are unpatentable under 35 U.S.C. § 103: (1) as obvious over Aumayer, Evans, and Wendt, and (2) as obvious over Tegethoff, Awada, Evans, and Wendt.

In consideration of the foregoing, it is

ORDERED that claims 10, 14, and 17, of the ’074 patent are CANCELLED;
FURTHER ORDERED that Cuozzo’s Motion to Exclude Evidence is *dismissed*; and

FURTHER ORDERED Cuozzo’s Motion to Amend Claims is *denied*.

Case IPR2012-00001
Patent 6,778,074

For PETITIONER:

Jennifer C. Bailey
HOVEY WILLIAMS LLP
jcb@hoveywilliams.com

For PATENT OWNER

John R. Kasha
Kasha Law LLC
john.kasha@kashalaw.com

Cabrach J. Connor
Reed & Scardino LLP
cconnor@reedscardino.com