

UNITED STATES DISTRICT COURT  
CENTRAL DISTRICT OF CALIFORNIA

Priority \_\_\_\_\_  
Send \_\_\_\_\_  
Enter \_\_\_\_\_  
Closed \_\_\_\_\_  
JS-5/JS-6 \_\_\_\_\_  
Scan Only \_\_\_\_\_

CIVIL MINUTES - GENERAL

CASE NO.: CV 13-06089 SJO (FFMx) DATE: January 23, 2015

TITLE: MAG Aerospace Industries, Inc. v. B/E Aerospace, Inc.

=====

**PRESENT: THE HONORABLE S. JAMES OTERO, UNITED STATES DISTRICT JUDGE**

Victor Paul Cruz Not Present  
Courtroom Clerk Court Reporter

**COUNSEL PRESENT FOR PLAINTIFF:** Not Present  
**COUNSEL PRESENT FOR DEFENDANT:** Not Present

=====

**PROCEEDINGS (in chambers): ORDER GRANTING PLAINTIFF'S MOTION FOR SUMMARY JUDGMENT AS TO ASSIGNOR ESTOPPEL [Docket No. 260] AND GRANTING IN PART DEFENDANT'S MOTION FOR SUMMARY JUDGMENT OF NONINFRINGEMENT AND INVALIDITY [Docket No. 261]**

This matter is before the Court on Plaintiff MAG Aerospace Industries, Inc.'s ("Plaintiff") Motion for Summary Judgment as to Assignor Estoppel ("Plaintiff's Motion"), and on Defendant B/E Aerospace, Inc.'s ("Defendant") Motion for Summary Judgment of Noninfringment and Invalidity ("Defendant's Motion"), both filed December 8, 2014. On December 22, 2014, Plaintiff and Defendant filed Oppositions to the Motions. On December 29, 2014, Plaintiff and Defendant filed Replies to the Oppositions. The Court held a hearing on this matter on January 15, 2015. For the following reasons, the Court **GRANTS** Plaintiff's Motion and **GRANTS IN PART** Defendant's Motion.

**I. FACTUAL AND PROCEDURAL BACKGROUND**

This case concerns three patents owned by Plaintiff: U.S. Patent Nos. 6,353,942 ("the '942 Patent"); 6,536,054 ("the '054 Patent"); and 6,536,055 ("the '055 Patent") (collectively, "Asserted Patents"). (See *generally* Compl., ECF No. 1.) The patents relate to vacuum toilet assemblies and methods for repairing these toilets. (Compl. ¶ 10 & Exs. A-C.) On August 20, 2013, Plaintiff filed the instant lawsuit alleging that Defendant's sale and manufacture of vacuum toilets for aircraft applications infringe multiple claims of the Asserted Patents. (See *generally* Compl.)

The application for the '942 Patent was filed on November 16, 2000, and the patent was issued on March 12, 2002. On February 1, 2002, a continuation application was filed, and the continuation was issued as the '055 Patent on March 25, 2003. A different patent application was also filed on November 16, 2000, and a continuation of this application was issued as the '054 Patent on March 25, 2003. Both the '942 Patent and the '055 Patent are titled "Modular Vacuum Toilet with Line Replaceable Units." These two patents describe a modular vacuum toilet and methods for repairing that toilet by replacing specific modules within the toilet without removing

UNITED STATES DISTRICT COURT  
#12070  
CENTRAL DISTRICT OF CALIFORNIA

Priority \_\_\_\_\_  
Send \_\_\_\_\_  
Enter \_\_\_\_\_  
Closed \_\_\_\_\_  
JS-5/JS-6 \_\_\_\_\_  
Scan Only \_\_\_\_\_

**CIVIL MINUTES - GENERAL**

**CASE NO.:** CV 13-06089 SJO (FFMx)

**DATE:** January 23, 2015

the entire toilet, thus making repair quicker and easier. The '054 Patent, titled "Vacuum Toilet Bowl Assembly Having Removable Bowl," describes a vacuum toilet with a toilet bowl positioned on a support frame. The toilet bowl can be removed and replaced without tools, again making repair simple and fast.

A claim construction hearing was held on July 2, 2014. On July 24, 2014, the Court issued an order construing four claim terms as follows:

- (1) "Out-turned flange supported by the top of the support structure"  
Found in Claims 1 and 13 of the '942 Patent ('942 Patent 10:13-14, 11:6-7)

**Outside rim or edge turned away from the sidewall, transferring loads to the top of the support structure.**

- (2) "Line replaceable unit ('LRU')"  
Found in Claims 13, 14, and 17 of the '942 Patent ('942 Patent 11:17-23, 24-25, 31-34) and Claims 1 and 15 of the '055 Patent ('055 Patent 10:35-40, 11:32-41)

**A single module targeted for easy replacement in the field.**

- (3) "Toollessly"  
Found in Claims 1 and 10 of the '054 Patent ('054 Patent 4:65, 5:23)

**Without the use of any tools.**

- (4) "Lifting the receptacle . . . so that . . ."  
Found in Claim 10 of the '054 Patent ('054 Patent 5:36-40).

The claim term "lifting the receptacle" means "**pulling in a generally upward direction on the receptacle.**" The rest of the phrase has its plain and ordinary meaning.

On December 8, 2014, the parties filed the instant motions for summary judgment. Plaintiff MAG seeks to strike the invalidity defenses asserted by Defendant B/E under the doctrine of assignor estoppel. Defendant B/E seeks summary judgment of noninfringement of all asserted claims of all asserted patents and summary judgment of invalidity of the asserted claims of the '942 and '054 Patents.

///  
///  
///

II. LEGAL STANDARDS

UNITED STATES DISTRICT COURT  
#12071  
CENTRAL DISTRICT OF CALIFORNIA

Priority \_\_\_\_\_  
Send \_\_\_\_\_  
Enter \_\_\_\_\_  
Closed \_\_\_\_\_  
JS-5/JS-6 \_\_\_\_\_  
Scan Only \_\_\_\_\_

**CIVIL MINUTES - GENERAL**

**CASE NO.:** CV 13-06089 SJO (FFMx)

**DATE:** January 23, 2015

A. Summary Judgment

Federal Rule of Civil Procedure 56(a) mandates that a court must "grant summary judgment if the movant shows that there is no genuine dispute as to any material fact and the movant is entitled to judgment as a matter of law." Fed. R. Civ. P. 56(a). The moving party bears the initial burden of establishing the absence of a genuine issue of material fact. *See Celotex Corp. v. Catrett*, 477 U.S. 317, 323 (1986). "When the party moving for summary judgment would bear the burden of proof at trial, it must come forward with evidence which would entitle it to a directed verdict if the evidence went uncontroverted at trial. In such a case, the moving party has the initial burden of establishing the absence of a genuine issue of fact on each issue material to its case." *C.A.R. Transp. Brokerage Co. v. Darden Rests., Inc.*, 213 F.3d 474, 480 (9th Cir. 2000) (citations and quotations omitted). In contrast, when the nonmoving party bears the burden of proving the claim or defense, the moving party does not need to produce any evidence or prove the absence of a genuine issue of material fact. *See Celotex Corp.*, 477 U.S. at 325. Rather, the moving party's initial burden "may be discharged by 'showing'—that is, pointing out to the district court—that there is an absence of evidence to support the nonmoving party's case." *Id.* Once the moving party meets its initial burden, the "party asserting that a fact cannot be or is genuinely disputed must support the assertion." Fed. R. Civ. P. 56(c)(1). "The mere existence of a scintilla of evidence in support of the [nonmoving party]'s position will be insufficient; there must be evidence on which the jury could reasonably find for the [nonmoving party]." *Anderson v. Liberty Lobby, Inc.*, 477 U.S. 242, 252 (1986); *accord Matsushita Elec. Indus. Co. v. Zenith Radio Corp.*, 475 U.S. 574, 586 (1986) (the nonmoving party "must do more than simply show that there is some metaphysical doubt as to the material facts."). Further, "[o]nly disputes over facts that might affect the outcome of the suit . . . will properly preclude the entry of summary judgment [and] [f]actual disputes that are irrelevant or unnecessary will not be counted." *Anderson*, 477 U.S. at 248. At the summary judgment stage, a court does not make credibility determinations or weigh conflicting evidence. *See Anderson*, 477 U.S. at 249. A court is required to draw all inferences in the light most favorable to the nonmoving party. *Matsushita*, 475 U.S. at 587. When evaluating a motion for summary judgment, the court views the record evidence through the prism of the evidentiary standard of proof that would pertain at a trial on the merits. *Anderson*, 477 U.S. at 254.

B. Noninfringement

"An infringement analysis entails two steps. The first step is determining the meaning and scope of the patent claims asserted to be infringed." *Markman v. Westview Instruments, Inc.*, 52 F.3d 967, 976 (Fed. Cir. 1995) (en banc) (citation omitted), *aff'd*, 517 U.S. 370 (1996). "The second step is comparing the properly construed claims to the device accused of infringing." *Id.*

Here, the claims have been construed. Thus, the Court may proceed to compare the Patents-in-Suit to the Products to determine whether the Defendants are liable for patent infringement. *See Bayer AG v. Elan Pharm. Research Corp.*, 212 F.3d 1241, 1247 (Fed. Cir. 2000). This is a

UNITED STATES DISTRICT COURT  
#12072  
CENTRAL DISTRICT OF CALIFORNIA

Priority \_\_\_\_\_  
Send \_\_\_\_\_  
Enter \_\_\_\_\_  
Closed \_\_\_\_\_  
JS-5/JS-6 \_\_\_\_\_  
Scan Only \_\_\_\_\_

**CIVIL MINUTES - GENERAL**

**CASE NO.:** CV 13-06089 SJO (FFMx)

**DATE:** January 23, 2015

question of fact. *Id.* (citing *Insituform Techs., Inc. v. Cat Contracting, Inc.*, 161 F.3d 688, 692 (Fed. Cir. 1998)). "To prevail, the plaintiff must establish by a preponderance of the evidence that the accused device infringes one or more claims of the patent either literally or under the doctrine of equivalents." *Id.* (citation omitted); see also *Warner-Jenkinson Co. v. Hilton Davis Chem. Co.*, 520 U.S. 17, 21 (1997).

1. Literal Infringement

"Literal infringement requires the patentee to prove that the accused device contains each limitation of the asserted claim(s) . . . If any claim limitation is absent from the accused device, there is no literal infringement as a matter of law." *Bayer AG*, 212 F.3d at 1247 (internal citation omitted). A product that does not infringe an independent claim cannot literally infringe a claim that is dependent on that independent claim. *London v. Carson Pirie Scott & Co.*, 946 F.2d 1534, 1539 (Fed. Cir. 1991) (citing *Wahpeton Canvas Co. v. Frontier, Inc.*, 870 F.2d 1546, 1552 n.9 (Fed. Cir. 1989)).

2. Infringement by Equivalents

Under the doctrine of equivalents, "a product or process that does not literally infringe upon the express terms of a patent claim may nonetheless be found to infringe if there is 'equivalence' between the elements of the accused product or process and the claimed elements of the patented invention." *Warner-Jenkinson*, 520 U.S. at 21 (citation omitted). A claim element is equivalently present in an accused device only if insubstantial differences distinguish the missing claim element from the corresponding aspects of the accused device. *Sage Prods., Inc. v. Devon Indus., Inc.*, 126 F.3d 1420, 1423 (Fed. Cir. 1997) (citation omitted). Prosecution history estoppel, however, may bar the patentee from asserting equivalents if the scope of the claims has been narrowed by amendment during prosecution. *Honeywell Int'l, Inc. v. Hamilton Sundstrand Corp.*, 370 F.3d 1131, 1139 (Fed. Cir. 2004) (en banc). "A patentee who narrow[ed] a claim as a condition for obtaining a patent disavow[ed] his claim to the broader subject matter . . ." and must not be allowed to recapture what he relinquished. See *Festo Corp. v. Shoketsu Kinzoku Kogyo Kabushiki Co. (Festo VIII)*, 535 U.S. 722, 737 (2002).

Estoppel may arise when an amendment is made to secure the patent, usually in response to an examiner's rejection, and to comply with any provision of the Patent Act. See *id.* at 733-34. A voluntary amendment, not required by the examiner or made in response to a rejection by an examiner, may also give rise to estoppel if the voluntary amendment narrows the scope of a claim. See *Festo Corp. v. Shoketsu Kinzoku Kogyo Kabushiki Co., Ltd. (Festo IX)*, 344 F.3d 1359, 1366 (Fed. Cir. 2003). In these situations, when the patentee surrendered subject matter during patent prosecution, the Court must presume that the patentee is precluded from using the doctrine of equivalents to recapture that subject matter. See *AquaTex Indus., Inc. v. Techniche Solutions*, 479 F.3d 1320, 1325 (Fed. Cir. 2007) (citations omitted). "[T]he rewriting of dependent claims into

#12073  
**UNITED STATES DISTRICT COURT  
 CENTRAL DISTRICT OF CALIFORNIA**

Priority \_\_\_\_\_  
 Send \_\_\_\_\_  
 Enter \_\_\_\_\_  
 Closed \_\_\_\_\_  
 JS-5/JS-6 \_\_\_\_\_  
 Scan Only \_\_\_\_\_

**CIVIL MINUTES - GENERAL**

**CASE NO.:** CV 13-06089 SJO (FFMx)

**DATE:** January 23, 2015

independent form coupled with the cancellation of the original independent claims [also] creates a presumption of prosecution history estoppel." *Honeywell*, 370 F.3d 1134. Even when the Court is "unable to determine the purpose underlying a narrowing amendment," the Court is required to "presume that the patentee surrendered all subject matter between the broader and the narrower language." *Festo VIII*, 535 U.S. at 740.

The patentee, however, may rebut this presumption by "demonstrat[ing] that the alleged equivalent would have been unforeseeable at the time of the narrowing amendment, that the rationale underlying the narrowing amendment bore no more than a tangential relation to the equivalent in question, or that there was 'some other reason' suggesting that the patentee could not reasonably have been expected to have described the alleged equivalent." *Festo IX*, 344 F.3d at 1368 (quoting *Festo VIII*, 535 U.S. at 740-41). In rebutting the presumption, the patentee "is restricted to the evidence in the prosecution history record." *Id.* at 1367 (citation omitted).

Prosecution history estoppel is determined by the Court. *Warner-Jenkinson*, 520 U.S. at 39 n.8. The Court is empowered to also resolve factual issues underlying the estoppel determination. See *DePuy Spine, Inc. v. Medtronic Sofamor Danek, Inc.*, 567 F.3d 1314, 1324 (Fed. Cir. 2009). The Court's determination of whether prosecution history estoppel applies is reviewed *de novo*, *Cybor Corp. v. FAS Techs., Inc.*, 138 F.3d 1448, 1460 (Fed. Cir. 1998) (en banc), but the resolution of underlying factual issues will not be disturbed unless those findings were made in clear error, *DePuy Spine*, 567 F.3d at 1324 (citation omitted).

### III. DISCUSSION

The Motions address Defendant's claims of invalidity and noninfringement of Plaintiff's patents. The issues of invalidity and noninfringement will be addressed in turn.

#### A. Invalidity

##### 1. Assignor Estoppel

As a preliminary matter, Plaintiff claims that assignor estoppel prevents Defendant from making its invalidity defense. "[A]ssignor estoppel is an equitable doctrine that prohibits an assignor of a patent or patent application, or one in privity with him, from attacking the validity of that patent when he is sued for infringement by the assignee." *Semiconductor Energy Lab. Co. v. Nagata*, 706 F.3d 1365, 1369 (Fed. Cir. 2013) (citing *Diamond Scientific Co. v. Ambico, Inc.*, 848 F.2d 1220, 1224 (Fed. Cir. 1988)). Assignor estoppel is an equitable challenge to a defense of invalidity, applied "to prevent unfairness and injustice." *Diamond*, 848 F.2d at 1224, 1227. The doctrine is "mainly concerned with the balance of the equities between the parties." *Shamrock Techs., Inc. v. Medical Sterilization, Inc.*, 903 F.2d 789, 793 (Fed. Cir. 1990). "Those in privity with

#12074  
**UNITED STATES DISTRICT COURT  
CENTRAL DISTRICT OF CALIFORNIA**

Priority \_\_\_\_\_  
Send \_\_\_\_\_  
Enter \_\_\_\_\_  
Closed \_\_\_\_\_  
JS-5/JS-6 \_\_\_\_\_  
Scan Only \_\_\_\_\_

**CIVIL MINUTES - GENERAL**

**CASE NO.:** CV 13-06089 SJO (FFMx)

**DATE:** January 23, 2015

the assignor partake of that balance; hence, extension of the estoppel to those in privity is justified." *Id.*

Here, one of the inventors of the patents in suit, Mark Pondelick, now works for Defendant. (Def.'s Opp'n 1.) Plaintiff alleges that Mr. Pondelick assigned the patents to his former employer, who in turn assigned them to Plaintiff. (Pl.'s Mem. P&A 6; Def.'s Opp'n 1.)

The most significant question is whether Mr. Pondelick is in privity with Defendant. The closer the relationship between an inventor and his or her new company, the more the equities will favor applying the doctrine of assignor estoppel to the new company. *Shamrock*, 903 F.2d at 793; *Mentor Graphics Corp. v. Quickturn Design Sys., Inc.*, 150 F.3d 1374, 1379 (Fed. Cir. 1998) (citations omitted). In *Shamrock*, for example, the court found privity where the inventor joined the defendant as vice president in charge of operations, owned 50,000 shares of stock in the defendant, oversaw the entry of the defendant into a new, infringing line of business, and was in charge of the defendant's infringing operations. See *Shamrock*, 903 F.2d at 794. A "corporation founded by [an] assignor" would be in privity with the assignor. *Diamond*, 848 F.2d at 1224. Further, privity has been found where a corporation of which the assignor/inventor was a major shareholder and chief executive officer directly transferred the technology to the defendant. See *Intel Corp. v. U.S. Int'l Trade Comm'n*, 946 F.2d 821, 838-39 (Fed. Cir. 1991). In *BASF Corp. v. Aristo, Inc.*, privity was found where the assignor, albeit a mere consultant, supervised the defendant's allegedly infringing operations and where the defendant "needed" the inventor's expertise to conduct infringement. 872 F. Supp. 2d 758, 775 (N.D. Ind. 2012). In another case, the court found privity where the inventor was initially a part-time consultant who "participated in design discussions" and later became Chief Architect of the defendant. *Brocade Commc'ns Sys., Inc. v. A10 Networks, Inc.*, No. 10-CV-03428-LHK, 2012 WL 2326064, at \*5-\*6 (N.D. Cal. June 18, 2012) (finding privity where the inventor was responsible for the design and wrote some code, and the allegedly infringing activity did not begin until after the assignors were involved).

A number of court decisions have also found a lack of privity. The court in *HWB, Inc. v. Braner, Inc.* found that there was no privity where the assignor/inventor was a vice president of sales at the defendant's company and did not start up the alleged infringing operations or oversee the construction of the facilities necessary to perform the infringing operations; rather, the defendant had purchased the assets of a third party company and continued to manufacture the products the third party had previously sold. 869 F.Supp. 579, 580-81 (N.D. Ill. 1994). In a second case, *Fiber Systems International v. Applied Optical Systems*, summary judgment of assignor estoppel was denied based on a dispute of material facts relating to privity: while the plaintiff had provided evidence that the assignor was a cofounder of the defendant, the defendant had produced evidence that the product was manufactured to government specifications and thus did not require the assignor's knowledge and skill to produce. See *Fiber Sys. Int'l v. Applied Optical Sys.*, No. 2:06-CV-473 (TJW-CE), 2008 U.S. Dist. LEXIS 121343 at \*6-\*7 (E.D. Tex. Sep. 8, 2008); cf. *Intel*, 946 F.2d at 839 ("What is significant is whether the ultimate infringer availed itself of the inventor's

UNITED STATES DISTRICT COURT  
#12075  
CENTRAL DISTRICT OF CALIFORNIA

Priority \_\_\_\_\_  
Send \_\_\_\_\_  
Enter \_\_\_\_\_  
Closed \_\_\_\_\_  
JS-5/JS-6 \_\_\_\_\_  
Scan Only \_\_\_\_\_

**CIVIL MINUTES - GENERAL**

**CASE NO.:** CV 13-06089 SJO (FFMx)

**DATE:** January 23, 2015

'knowledge and assistance' to conduct infringement."). A third district court found there was no assignor estoppel in a case where the assignor was one of twenty-six vice presidents of the defendant and owned an insignificant number of the defendant's shares. *Acushnet Co. v. Dunlop Maxfli Sports Corp.*, No. CIV. A. 98-717-SLR, 2000 WL 987979, at \*3 (D. Del. June 29, 2000).

Defendant argues that its attempts not to infringe, as illustrated by the fact that it consulted outside counsel to work around the patent claims, should prevent assignor estoppel from being applied. However, it does not matter whether or not Defendant thought it was infringing the patents in suit. The Federal Circuit has made clear that "an illicit purpose is not necessary to conclude that there was privity." *Intel*, 946 F.2d at 839. The privity section of the *Intel* decision refers to an "allegedly infringing" product and does not include actual infringement in its list of factors contributing to its finding of privity. Accordingly, the Court finds that Defendant's efforts to avoid infringement are not relevant to whether Mr. Pondelick and Defendant are in privity.

Courts have found it helpful to analyze the factors that contributed to a finding of privity in *Shamrock*. See, e.g., *Brocade*, 2012 WL 2326064 at \*5. While these factors are not dispositive, they provide useful guidance. The Court will analyze each factor individually as in *Brocade*, *id.* at \*5-\*9.

1. *The Assignor's Leadership Role at the New Employer.* The Federal Circuit in *Shamrock*, in support of its finding of privity, noted that the assignor left the plaintiff to join the defendant as vice president in charge of operations. Here, Defendant initially hired Mr. Pondelick as a consultant in February 2008. (Def.'s Statement of Genuine Disputes ¶ 23.) Defendant paid Mr. Pondelick \$23,000 per month for 35 hours per week pursuant to his consulting agreement. (Def.'s Statement of Genuine Disputes ¶ 25.) The parties dispute what Mr. Pondelick's role was during his time as a consultant. Plaintiff contends that Mr. Pondelick was hired as a consultant to lead the development of Defendant's vacuum toilet. (Pl.'s Statement of Uncontroverted Facts ¶¶ 23, 28.) Plaintiff cites the testimony of Robert Schafer that "Mark Pondelick was in charge of the design team." (Mosley Decl. Ex. G ("Schafer Dep.") 22:11-14.) Defendant disagrees, citing Mr. Pondelick's testimony that no "particular person" was responsible for the overall design and Mr. Schafer's testimony that the hiring of new employees had been delegated to Mr. Hoang. (Mosley Decl. Ex. D 79:17-22; Haber Decl. Ex. S ("Schafer Dep.") 114:1-9.) However, one need not be solely responsible for the design or involved in hiring to be in a leadership role, so this is not sufficient to raise a genuine dispute of material fact. Defendant's own documents indicate that Mr. Pondelick acted "as the Director of Engineering" for B/E Ecosystems during his time as a consultant, and the Court finds this dispositive that Mr. Pondelick had a leadership role. (Mosley Decl. Ex. L 271.)

In approximately June 2012, Mr. Pondelick's title changed to Vice President and General Manager of B/E EcoSystems, a small division of Defendant. (Def.'s Statement of Genuine Disputes ¶ 39.) This clearly constitutes a leadership role. In 2013 Mr. Pondelick signed a contract on behalf of

UNITED STATES DISTRICT COURT  
#12076  
CENTRAL DISTRICT OF CALIFORNIA

Priority \_\_\_\_\_  
Send \_\_\_\_\_  
Enter \_\_\_\_\_  
Closed \_\_\_\_\_  
JS-5/JS-6 \_\_\_\_\_  
Scan Only \_\_\_\_\_

**CIVIL MINUTES - GENERAL**

**CASE NO.:** CV 13-06089 SJO (FFMx)

**DATE:** January 23, 2015

Defendant to replace and maintain Alaska Airlines' vacuum toilets. (See Mosley Decl. Ex. M 9.) The facts here are very similar to *Brocade*. Here as in *Brocade*, the assignor was initially a part-time consultant and then took on a clear leadership role at Defendant. "Privity does not require that the assignor directly design the infringing features of the accused product." *Brocade*, 2012 WL 2326064 at \*5 (citing *Mentor Graphics*, 150 F.3d at 1379). Here, as in *Brocade*, there is no material dispute as to this factor.

2. *The Assignor/Inventor's Ownership Stake in the Defendant Company.* The *Shamrock* court found it significant that the assignor owned 50,000 shares of stock in the defendant. *Shamrock*, 903 F.2d at 794. It is undisputed that Mr. Pondelick owns stock in Defendant. (Def.'s Statement of Genuine Disputes ¶ 44.) The amount of stock owned, however, is disputed: Defendant argues that Mr. Pondelick owns around 150-200 shares of B/E stock, citing Mr. Pondelick's testimony to that effect, while Plaintiff argues that Mr. Pondelick owns over 1,000 shares of stock, citing Mr. Pondelick's subsequent testimony that "it could be slightly more than 1,000." (Mosley Decl. Ex. D 184:12-14.) In either case, given that over one hundred million shares are outstanding, this amounts to no more than about one thousandth of one percent of the company. If, as Defendant has shown, the B/E EcoSystems subsidiary accounted for around \$2.53 million (0.07%) of Defendant's total revenue in 2013, Mr. Pondelick stood to gain less than \$30 per year of the subsidiary's revenue as a B/E shareholder. (See Def.'s Additional Undisputed Facts ¶ 44.)

Plaintiff also points out that Mr. Pondelick stands to benefit from Defendant's performance in other ways. It is undisputed that Mr. Pondelick participates in an executive-level stock indexed bonus program and an employee stock purchase program. (Def.'s Statement of Genuine Disputes ¶ 43.) It is also undisputed that Mr. Pondelick participates in a management incentive program. (Def.'s Statement of Genuine Disputes ¶ 42.) Defendant provides evidence that this program depends on the performance of the facility he manages and is paid out at a capped discretionary percentage of his base salary. (Def.'s Statement of Genuine Disputes ¶ 42.) Defendant also provides uncontroverted evidence that these programs are standardized, company-wide programs. Plaintiff has not shown that the compensation from these programs creates anything more than a minimal ownership interest in Defendant. Thus, this factor does not significantly weigh toward a finding of privity. However, a lack of significant ownership does not necessarily preclude a finding of privity if Defendant availed itself of Mr. Pondelick's knowledge and assistance to conduct infringement. See *Intel*, 946 F.2d at 839.

3. *Whether the Defendant Company Changed Course from Manufacturing Non-Infringing Goods to Infringing Activity After the Inventor Was Hired.* The *Shamrock* court found it significant that the defendant corporation was formed for completely unrelated, non-infringing purposes but built facilities for allegedly infringing activity as soon as the assignor was hired. *Shamrock*, 903 F.2d at 794. It is undisputed that Defendant set out to design a vacuum waste system in October 2007. (Def.'s Statement of Genuine Disputes ¶ 16.) It is also undisputed that Mr. Schafer was hired by Defendant in November 2007 and that his role included the task of developing a team to design,

UNITED STATES DISTRICT COURT  
#12077  
CENTRAL DISTRICT OF CALIFORNIA

Priority \_\_\_\_\_  
Send \_\_\_\_\_  
Enter \_\_\_\_\_  
Closed \_\_\_\_\_  
JS-5/JS-6 \_\_\_\_\_  
Scan Only \_\_\_\_\_

**CIVIL MINUTES - GENERAL**

**CASE NO.:** CV 13-06089 SJO (FFMx)

**DATE:** January 23, 2015

develop, market, and manufacture vacuum waste systems. (Def.'s Statement of Genuine Disputes ¶ 17.) It is also undisputed that Defendant and Mr. Schafer had discussed hiring Mr. Pondelick before Mr. Schafer was hired in November 2007. (Def.'s Statement of Genuine Disputes ¶ 18.) According to Defendant, Mr. Pondelick began consulting in February 2008. (Def.'s Additional Undisputed Facts ¶ 18.) While it is clear that Mr. Pondelick was involved at a very early stage in Defendant's development of vacuum waste systems, it appears that Defendant changed course slightly before, not after, Mr. Pondelick was hired. B/E had at least "rough sketches" at the time Mr. Pondelick was hired. (Def.'s Statement of Genuine Disputes ¶ 27.) Thus, this factor does not clearly weigh toward a finding of privity, though it alone does not preclude a finding of privity.

*4. The Assignor's Role in the Infringing Activities.* The *Shamrock* court found it significant that the assignor oversaw the design and construction of the defendant's allegedly infringing facilities. *Shamrock*, 903 F.2d at 794. It is undisputed that Mr. Pondelick was significantly involved in the design of the toilets. (See Def.'s Statement of Genuine Disputes ¶¶ 28-30.) While it is disputed whether Mr. Pondelick in fact took a leadership role during his time as a consultant, Defendant has stated that the majority of its vacuum toilet business "is based on [Mr. Pondelick's] designs" and that Mr. Pondelick had been "essential to its success." (Def.'s Statement of Genuine Disputes ¶ 37; Mosley Decl. Ex. L 271.) Defendant contends that the requirement of using a removable bowl, which is central to Plaintiff's infringement accusations, had been established by engineers in Anaheim before Mr. Pondelick was retained as a part-time consultant. (Def.'s Additional Undisputed Facts ¶ 23; Hoang Decl. ¶ 9.) However, the Federal Circuit "has not required that the assignor be personally involved in designing the allegedly infringing aspects of a product before finding the doctrine of assignor estoppel applicable." *Synopsys, Inc. v. Magma Design Automation, Inc.*, 04-CV-3923-MMC, 2005 WL 1562779, at \*6 (N.D. Cal. July 1, 2005). Overall, this factor weighs toward a finding of privity.

*5. Whether the Inventor Was Hired to Start the Infringing Operations.* The *Shamrock* court found it significant that the assignor was hired in part to start up the defendant's allegedly infringing operations. *Shamrock*, 903 F.2d at 794. Defendant admits that "Mr. Pondelick was hired because he was (and is) a very competent vacuum toilet engineer with a good reputation, and he was available and interested in developing a new vacuum waste system for B/E." (Def.'s Statement of Genuine Disputes ¶ 31.) There is no dispute that Mr. Pondelick was hired to help start Defendant's vacuum waste business. Defendant argues that when Mr. Pondelick was hired it was not for the express purpose of building infringing vacuum toilets but rather for building vacuum waste systems generally. However, the fact remains that the operations Mr. Pondelick was hired to help start are the operations now accused of infringement. Thus, this factor weighs toward a finding of privity.

*6. Whether the Decision to Manufacture the Infringing Product Was Made Partly by the Inventor.* The *Shamrock* court found it significant that the decision to begin infringing activity was made

UNITED STATES DISTRICT COURT  
CENTRAL DISTRICT OF CALIFORNIA

Priority \_\_\_\_\_  
Send \_\_\_\_\_  
Enter \_\_\_\_\_  
Closed \_\_\_\_\_  
JS-5/JS-6 \_\_\_\_\_  
Scan Only \_\_\_\_\_

CIVIL MINUTES - GENERAL

CASE NO.: CV 13-06089 SJO (FFMx)

DATE: January 23, 2015

jointly by the assignor and the defendant's president. *Shamrock*, 903 F.2d at 794. As discussed above, the general decision to enter the vacuum waste business was made before Mr. Pondelick started working for Defendant. Mr. Pondelick was involved in the toilet design concept and the design of the valves. (Def.'s Statement of Genuine Disputes ¶ 29.) The Court in *Brocade* held that in a case like this where the assignor participated in decisions related to the manufacture, it is immaterial whether the assignor participated in the ultimate decision of whether to manufacture the product or not: the sixth *Shamrock* factor does not preclude a finding of privity. See *Brocade*, 2012 WL 2326064 at \*8.

7. *Whether the Defendant Company Began Manufacturing the Accused Product Shortly After Hiring the Inventor/Assignor.* The *Shamrock* court found it significant that the defendant began manufacturing the accused product roughly two years after hiring the assignor. *Shamrock*, 903 F.2d at 794. Here, Mr. Pondelick began consulting for Defendant in February 2008. (Def.'s Additional Undisputed Facts ¶ 18.) The parties have not specified when manufacturing of the accused products began. (See generally Pl.'s Statement of Uncontroverted Facts; Def.'s Additional Undisputed Facts.) However, given that development had just started when Mr. Pondelick was hired, this does not raise a genuine dispute that would preclude a finding of privity.

8. *Whether the Inventor/Assignor Was in Charge of the Infringing Operation.* The *Shamrock* court found it significant that the assignor was in charge of the defendant's allegedly infringing operations. *Shamrock*, 903 F.2d at 794. In 2012, Mr. Pondelick became Vice President of Engineering for B/E EcoSystems, the division that manufactured the accused toilets. (Def.'s Statement of Genuine Disputes ¶ 38.) It is not material that the assignor was "initially a part-time consultant." *Brocade*, 2012 WL 2326064 at \*8. This factor weighs toward a finding of privity.

In sum, all the *Shamrock* factors either weigh toward a finding of privity or fail to raise a genuine dispute that would preclude a finding of privity. The Court finds that Defendant availed itself of Mr. Pondelick's "knowledge and assistance" to conduct infringement, and thus Defendant and Mr. Pondelick are in privity. Defendant is therefore estopped from arguing the invalidity of the asserted patents. Accordingly, Plaintiff's Motion for Summary Judgment is **GRANTED**.

2. Anticipation and Indefiniteness

Defendant's Motion for Summary Judgment seeks a finding of invalidity based on anticipation and indefiniteness. First, Defendant argues that the asserted claims of the '942 Patent are invalid because the claims are anticipated by prior art vacuum toilet systems and their associated documentation. Second, Defendant argues that claims 1, 4-7, and 9 of the '054 Patent are invalid as indefinite, as a matter of law, because the claims attempt to cover a mixed method and apparatus in violation of *IPXL Holdings, L.L.C. v. Amazon.com, Inc.*, 430 F.3d 1377, 1384 (Fed. Cir. 2005) and related cases. As discussed above, Defendant is estopped from making these invalidity arguments.

UNITED STATES DISTRICT COURT  
CENTRAL DISTRICT OF CALIFORNIA

Priority \_\_\_\_\_  
Send \_\_\_\_\_  
Enter \_\_\_\_\_  
Closed \_\_\_\_\_  
JS-5/JS-6 \_\_\_\_\_  
Scan Only \_\_\_\_\_

CIVIL MINUTES - GENERAL

CASE NO.: CV 13-06089 SJO (FFMx)

DATE: January 23, 2015

With respect to Defendant's claims against the '054 Patent, Defendant argues that assignor estoppel cannot apply to invalidity issues that arose after Mr. Pondelick's assignment. Specifically, Defendant argues that the invalidity challenge to Claim 1 of the '054 Patent is based on claim language that was added after Mr. Pondelick's assignment.

Defendant correctly notes that an assignor has no way of knowing what future amendments may be made to the claims in an assigned patent application. However, courts generally do not let this fact bar the application of assignor estoppel. "That [plaintiff] may have later amended the claims in the application process . . . does not give [defendants'] arguments against estoppel any greater force." *Diamond*, 848 F.2d at 1226; see also *BASF*, 872 F. Supp. 2d at 774-75 (discounting assignor's argument that claims were changed during prosecution without assignor's approval). Case law does not provide a specific exception for claim amendments made after assignment. However, *Diamond* suggests that there may be an exception if the claims are later improperly broadened: "to the extent [Plaintiff] may have broadened the claims . . . beyond what could be validly claimed in light of the prior art, *Westinghouse* may allow appellants to introduce evidence of prior art to narrow the scope of the claims of the patents." *Id.* (citing *Westinghouse Elec. & Mfg. Co. v. Formica Insulation Co.*, 266 U.S. 342, 352-53 (1924)).

In this case, Defendant's validity challenge is based on the language "wherein the receptacle is toollessly inserted into and removed from . . ." This language was added to Claim 1 of the '054 Patent after Mr. Pondelick's assignment took place. (Def.'s Mot. 24-25.) Defendant argues that the claim is invalid because it is an apparatus claim yet the added language improperly recites a method for using that apparatus. See *IPXL Holdings, L.L.C. v. Amazon.com, Inc.*, 430 F.3d 1377, 1384 (Fed. Cir. 2005).

This amendment was made after Mr. Pondelick's assignment, and Defendant argues that it would be unfair to hold Mr. Pondelick and Defendant unable to challenge claims they had no hand in creating. But here, Mr. Pondelick continued to provide feedback in the prosecution of the patent application after the initial assignment. (See Def.'s Statement of Genuine Disputes ¶ 12.) In any event, the amendment narrowed rather than broadened the claim, and there is no case law supporting the concept that assignor estoppel does not apply where narrowing amendments occurred after assignment. Accordingly, Defendant is estopped from arguing that the '054 Patent is invalid. Defendant's Motion is **DENIED** with respect to invalidity.

B. Noninfringement

Defendant's Motion for Summary Judgment seeks a finding of noninfringement for each of the three asserted patents. The Court will address Defendant's arguments for each patent in turn. The parties make numerous evidentiary objections on various grounds. To the extent this order relies on evidence objected to, those evidentiary objections are overruled.

UNITED STATES DISTRICT COURT  
CENTRAL DISTRICT OF CALIFORNIA

Priority \_\_\_\_\_  
Send \_\_\_\_\_  
Enter \_\_\_\_\_  
Closed \_\_\_\_\_  
JS-5/JS-6 \_\_\_\_\_  
Scan Only \_\_\_\_\_

CIVIL MINUTES - GENERAL

CASE NO.: CV 13-06089 SJO (FFMx)

DATE: January 23, 2015

1. '054 Patent

Defendant seeks summary judgment that B/E does not infringe the asserted claims of U.S. Pat. No. 6,536,054 because there can be no genuine dispute that the B/E toilet bowl is not "toollessly" inserted and removed. (Def.'s Mem. P & A 3-7.) Claim 1 of the '054 Patent reads as follows:

1. A waste receptacle assembly for use in a vacuum toilet system having an inlet coupling, the waste receptacle assembly comprising:
  - a frame including at least two vertical supports and a top member attached to the at least two vertical supports, the top member defining an opening and having a receptacle engaging portion; and
  - a receptacle sized for at least partial insertion through the frame top member opening, the receptacle having an abutting portion positioned to engage the receptacle engaging portion of the frame when the receptacle is at least partially inserted through the frame top member opening thereby to maintain the receptacle in an installed position, the receptacle further having an outlet sized and adapted for releasable sealing engagement with the inlet coupling when the receptacle is in the installed position;
 wherein **the receptacle is toollessly inserted into and removed from** the installed position independent of the frame.

U.S. Patent No. 6,536,054 (emphasis added). Claims 2-9, the other system claims in the patent, are dependent upon Claim 1. The Court previously construed "toollessly" to mean "without the use of any tools." (Order Construing Claim Terms ("Markman Order") 13-14.)

The accused B/E toilet bowl is partly secured to the frame using 1/4-turn fasteners. (Pl.'s Statement of Genuine Disputes ¶ 4.) Defendant argues that at least a coin is necessary to loosen these 1/4-turn fasteners, that a coin is a tool within the meaning of the patent claims, and therefore that the B/E toilet bowl cannot infringe a patent claim requiring it to be toollessly inserted and removed. (Def.'s Mem. P & A 3.) Plaintiff responds that B/E's documentation repeatedly states that the toilet can be disassembled and assembled without tools, and that genuine issues of material fact remain regarding whether a coin is a tool. (See Def.'s Opp'n 2-7.)

First, while the Court did not explicitly construe the term "tool" in its claim construction order, the Court made clear that even nonconventional tools such as a coin would be considered tools in the context of the '054 Patent. (Markman Order 13-14.) "[T]he claims and specification never describe the types of tools that could or could not be used to remove or install the toilet, nor does the patent make any reference to mechanics. Furthermore, that these toilets are typically repaired by mechanics does not compel the interpretation that the term 'toollessly' is limited only to those tools commonly used by mechanics." (Markman Order 14.) Plaintiff identifies testimony from a

UNITED STATES DISTRICT COURT  
CENTRAL DISTRICT OF CALIFORNIA

Priority \_\_\_\_\_  
Send \_\_\_\_\_  
Enter \_\_\_\_\_  
Closed \_\_\_\_\_  
JS-5/JS-6 \_\_\_\_\_  
Scan Only \_\_\_\_\_

CIVIL MINUTES - GENERAL

CASE NO.: CV 13-06089 SJO (FFMx)

DATE: January 23, 2015

number of witnesses suggesting that a coin is not a tool in this context and argues that this creates a disputed issue of material fact. (Pl.'s Opp'n 6.) However, the Court has already implicitly rejected Plaintiff's argument in its claim construction order, which controls the interpretation of the term "toollessly." Accordingly, the Court will consider a coin to be a tool for the purposes of the claims of the '054 Patent.

The remaining issue, then, is whether a coin (or other tool) is in fact necessary to remove the fasteners and release the toilet bowl. Plaintiff argues that no coin is necessary. (Pl.'s Opp'n 2-3.) Notably, Plaintiff cites 29 of Defendant's documents which state that Defendant's toilets are serviceable "without tools" and the testimony of a B/E employee, Mr. Neary, who stated that the turns could be done by hand. (Pl.'s Statement of Additional Undisputed Facts ¶¶ 3-4, 20-22.)

Defendant, on the other hand, contends that at least a coin is necessary. (Def.'s Mem. P & A 4.) Defendant contends that the documents cited by Plaintiff are marketing documents, not maintenance manuals, that contain inadvertent errors. (Def.'s Mem. P & A 6-7.) Defendant cites testimony claiming that these documents are erroneous. (Def. Statement of Undisputed Facts ¶ 20.) Defendant further notes that Plaintiff's theory that the toilets can be removed using only a fingernail was not disclosed in any of MAG's infringement contentions. (Def.'s Mem. P & A 7.)

Plaintiff relies heavily on deposition testimony from Mr. Neary to support its contention that no coin is necessary. Mr. Neary was asked, "Do you recall which components could be released without tools?" (Haber Decl. Ex. G, Neary Dep. ("Neary Dep.") 56:5-6.) His response, though somewhat rambling, indicated that "through the trials . . . we . . . introduced some quick turns that didn't require a . . . coin or anything" and that "[y]ou could release the rinse, flush, and bowl." (Neary Dep. 56:9-57:9.) Later in the same deposition, however, Mr. Neary was asked more directly whether he was able to remove a toilet bowl without tools: "And were you able do to it without using tools?" (Neary Dep. 159:5.) He responded: "I used a quarter. I've used a euro. I've used a Brazilian real. Every time we do it, we'd show that you could do it with a coin. Almost every time, a mechanic reaches in their pocket and hands you their own coin. It's – it's pretty fun." (Neary Dep. 159:7-11.) And Mr. Neary was later asked in reference to the fasteners, "You said you used a coin. So in other words, you used some sort of device or implement other than your bare hands to remove those fasteners; correct?" (Neary Dep. 181:14-16.) He responded "Yes." (Neary Dep. 181:19.) Taking Mr. Neary's testimony as a whole, it is clear that he considered it necessary to use a coin to remove the toilet bowl.

Defendant argues that Plaintiff did not disclose in its Final Infringement Contentions any theory that the B/E toilets could be removed using one's fingernail. (Pl.'s Statement of Genuine Disputes ¶ 34). Plaintiff responds that the Final Infringement Contentions identified that Defendant's documents indicated B/E toilets are "designed to be dis-assembled, assembled, maintained, and serviced without tools." (Pl.'s Statement of Genuine Disputes ¶ 34; Mosley Decl. Ex. BE, MAG's Final Infringement Contentions, Ex. 3 ("Infringement Contentions") 13). However, in the Final

UNITED STATES DISTRICT COURT  
CENTRAL DISTRICT OF CALIFORNIA

Priority \_\_\_\_\_  
Send \_\_\_\_\_  
Enter \_\_\_\_\_  
Closed \_\_\_\_\_  
JS-5/JS-6 \_\_\_\_\_  
Scan Only \_\_\_\_\_

CIVIL MINUTES - GENERAL

CASE NO.: CV 13-06089 SJO (FFMx)

DATE: January 23, 2015

Infringement Contentions, this quote is immediately followed by a statement: "For example, B/E documents explain that the B/E toilet bowls can be removed with coins. Thus, the receptacle may be removed and replaced without the use of any tools." (Infringement Contentions 13 (citation omitted).) Given this context, it is clear that Plaintiff did not explicitly contend that B/E toilets could be removed using a fingernail, but instead envisioned that removal "without tools" could be accomplished through the use of a coin.

It is undisputed that Defendant has produced a large number of documents containing the phrases "Except for two (2) fasteners, the LRUs are designed to be assembled, maintained, and serviced without tools," or "The Modular Replaceable Units are designed to be assembled, maintained, and serviced without special tools." (Pl.'s Statement of Genuine Disputes ¶ 21.) Some documents, however, are less specific, containing language like the following:

The toilet is designed to be dis-assembled, assembled, maintained, and serviced without tools. The ¼ turn fasteners to remove and replace the toilet bowl are located at the front of the toilet assembly for ease of access and to lock the toilet bowl to the toilet structure."

(Pl.'s Statement of Additional Undisputed Facts ¶ 4.) Given the significant evidence that a coin or other tool is in fact necessary to remove the toilet bowl, and given that there is some inherent ambiguity in whether or not a coin is considered a tool, it seems to the Court that this statement is simply using a definition of "tools" that excludes coins. Further, two of B/E's witnesses testified that the statement that the toilet is "designed to be disassembled, assembled, maintained, and serviced without tools" is erroneous. (Haber Decl. Ex. K (Pondelick Aug 22 Dep.) 148:1-149:6; Haber Decl. Ex. H (Montiero Dep.) 170:1-171:20.)

Considering all of the above evidence, the Court finds that there is no genuine dispute of material fact that a coin or other tool is necessary to remove the toilet bowl. Because the asserted claims require that the bowl be removed "toollessly," the Court **GRANTS** summary judgment of noninfringement with respect to the asserted claims of the '054 Patent.

Finally, Defendant also seeks summary judgment of noninfringement of claims 10, 12-15, and 17 (the method claims) of the '054 patent. (Def.'s Mem. P & A 8.) Plaintiff admitted at the hearing that it has offered no expert testimony regarding infringement of these claims and that it has "voluntarily declined to pursue [these] claims" at this stage of the lawsuit. (Pl.'s Statement of Genuine Disputes ¶¶ 37, 38.) Plaintiff argues that there is no need to adjudicate these claims now. (Pl.'s Opp'n 7.) However, there has been no order dismissing these claims without prejudice, and MAG has failed to adequately pursue its claims of infringement. Further, the method claims also require toolless removal, and as discussed above, the "toollessly" portion of the claim language means that B/E's toilet bowls, which can only be removed using a tool, do not

UNITED STATES DISTRICT COURT  
CENTRAL DISTRICT OF CALIFORNIA

Priority \_\_\_\_\_  
Send \_\_\_\_\_  
Enter \_\_\_\_\_  
Closed \_\_\_\_\_  
JS-5/JS-6 \_\_\_\_\_  
Scan Only \_\_\_\_\_

CIVIL MINUTES - GENERAL

CASE NO.: CV 13-06089 SJO (FFMx)

DATE: January 23, 2015

infringe. Accordingly, the Court **GRANTS** summary judgment of noninfringement with respect to claims 10, 12-15, and 17 of the '054 patent.

2. '942 Patent - Out-Turned Flange

Defendant seeks summary judgment that it does not infringe the asserted claims of the '942 Patent. Defendant contends that there can be no genuine dispute that the B/E toilet does not, literally or under the doctrine of equivalents, have "an out-turned flange supported by the top of the support structure." The Court previously construed the phrase "out-turned flange supported by the top of the support structure," found in Claims 1 and 13 of the '942 Patent, to mean "outside rim or edge turned away from the sidewall, transferring loads to the top of the support structure." (Markman Order 9, 16.)

Plaintiff argues that the surfaces (which it refers to as "edges") at the bottom of the ribs on the side of B/E's toilets constitute an "out-turned flange" as described in the '942 patent. (Pl.'s Opp'n 8.) The Court, however, noted in its claim construction order that "a person having ordinary skill in the art would understand 'flange' to include rims and edges, but not ribs." (Markman Order 8.) The question faced by the Court, then, is whether the Defendant's toilet bowl is resting on "ribs" or "edges."

UNITED STATES DISTRICT COURT  
CENTRAL DISTRICT OF CALIFORNIA

Priority \_\_\_\_\_  
Send \_\_\_\_\_  
Enter \_\_\_\_\_  
Closed \_\_\_\_\_  
JS-5/JS-6 \_\_\_\_\_  
Scan Only \_\_\_\_\_

CIVIL MINUTES - GENERAL

CASE NO.: CV 13-06089 SJO (FFMx)

DATE: January 23, 2015

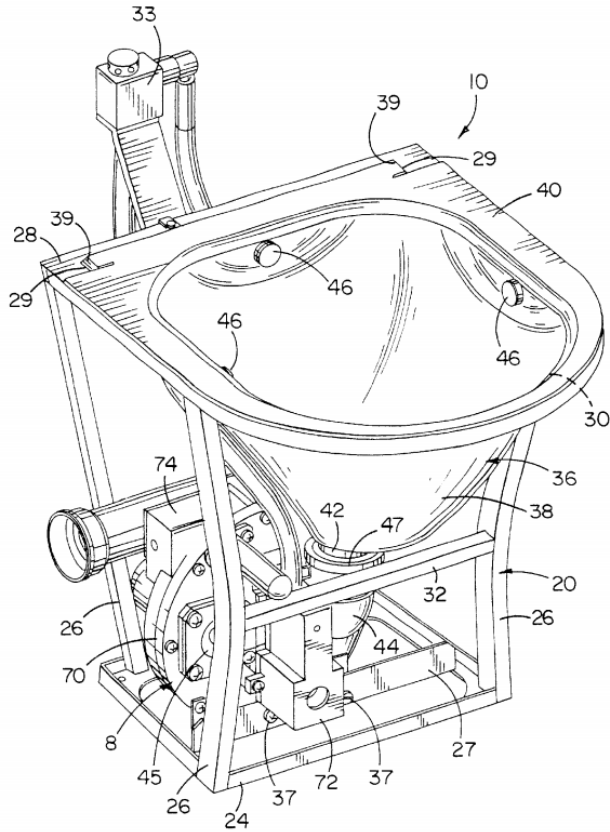

FIG. 1A

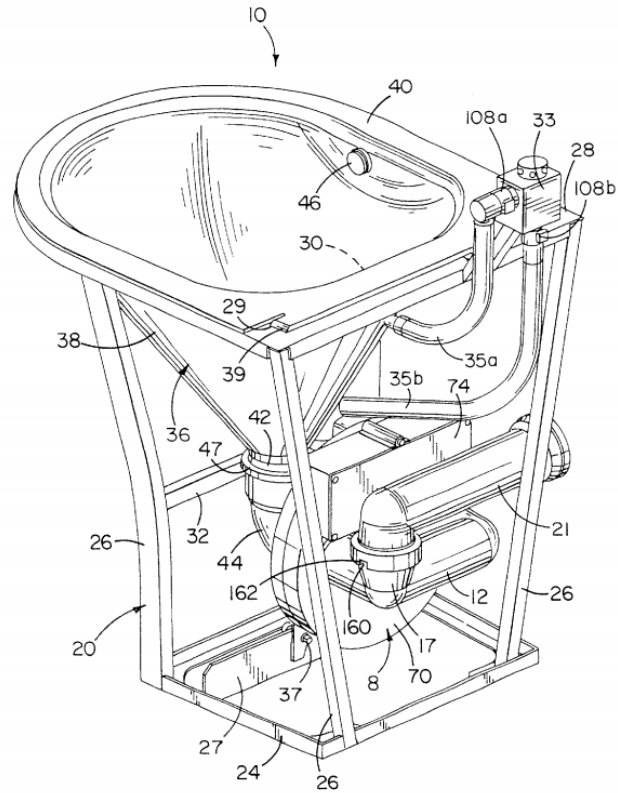

FIG. 1B

**Figure 1: Figures 1A and 1B of the '942 Patent.** These figures illustrate a vacuum toilet having a waste bowl 36, with the bowl having "a curved sidewall 38 and an out-turned flange 40 extending about an upper edge of the sidewall." ('942 Patent 4:53-55.)

UNITED STATES DISTRICT COURT  
CENTRAL DISTRICT OF CALIFORNIA

Priority \_\_\_\_\_  
Send \_\_\_\_\_  
Enter \_\_\_\_\_  
Closed \_\_\_\_\_  
JS-5/JS-6 \_\_\_\_\_  
Scan Only \_\_\_\_\_

CIVIL MINUTES - GENERAL

CASE NO.: CV 13-06089 SJO (FFMx)

DATE: January 23, 2015

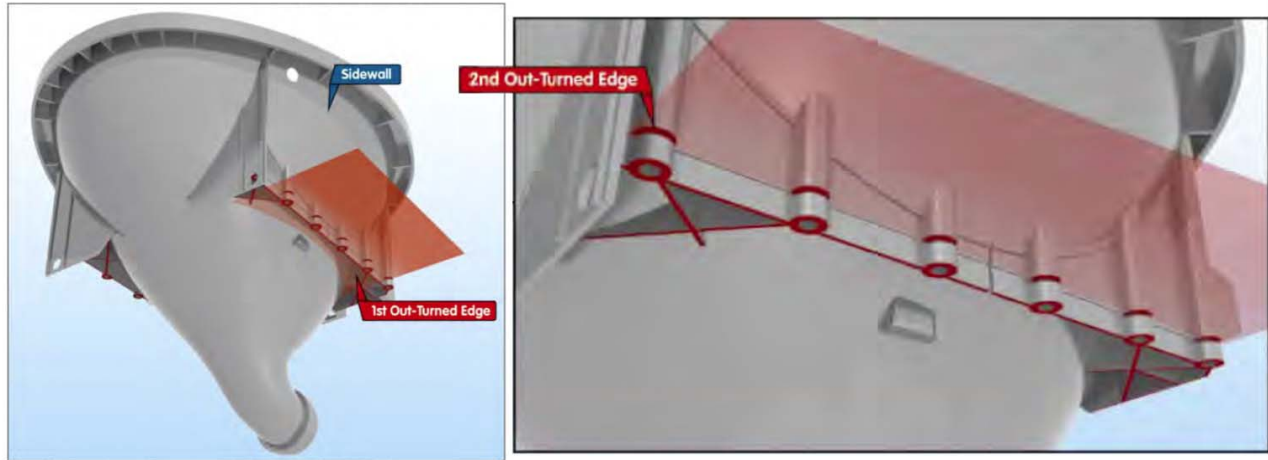

**Figure 2: B/E's CAD Drawings.** These excerpts from Defendant's CAD figures illustrate two different planes adjacent to the ribs on Defendant's toilet bowl. Defendant refers to them as "edges." (Meyers Decl. Ex. B Appx. C, Part 1 of 3, 19-20.)



**Figure 3: Photo of Support Structure.** Defendant cites this photo as evidence that there is a gap of approximately one-eighth of an inch between the bottom surface of the B/E toilet identified by Mr. Meyers and the support structure. (Def.'s Statement of Undisputed Facts ¶ 51; Haber Decl. Ex. Y.)

The analysis is further complicated by the fact that there are two different places on the ribs where the toilet bowl might be resting. One surface, referred to in Figure 2 as the "1st Out-Turned Edge," is at the very bottom of the ribs. The second surface, referred to as the "2nd Out-Turned Edge," is a notch above the first surface. Defendant claims that the toilet bowl does not rest on the first surface, since there is a gap of one-eighth of an inch between the bottom of the ribs and the support structure. (Def.'s Statement of Undisputed Facts ¶ 51.) Plaintiff disagrees, citing

UNITED STATES DISTRICT COURT  
CENTRAL DISTRICT OF CALIFORNIA

Priority \_\_\_\_\_  
Send \_\_\_\_\_  
Enter \_\_\_\_\_  
Closed \_\_\_\_\_  
JS-5/JS-6 \_\_\_\_\_  
Scan Only \_\_\_\_\_

CIVIL MINUTES - GENERAL

CASE NO.: CV 13-06089 SJO (FFMx)

DATE: January 23, 2015

computer-aided design drawings that show no gap. (Pl.'s Statement of Genuine Disputes ¶ 51.) Defendant, however, provides evidence that this was an early conceptual design that was never actually implemented. (Def.'s Statement of Undisputed Facts ¶ 52.)<sup>1</sup> Without some evidence that the CAD drawing was actually produced as a real product, this is not sufficient to create a genuine material dispute. Accordingly, the Court finds that the first surface cannot be the claimed flange.

Plaintiff's expert cites a finite element analysis simulation showing load transfer around the two surfaces. (Pl.'s Additional Material Facts ¶ 31; Meyers Decl. Ex. B Appx. C, Part 1 of 3, 25-26.) While this simulation clearly shows that load transfer occurs in the area of the two surfaces, the simulation does not show whether load is transferred on both surfaces or only on the second surface. At oral argument, Plaintiff suggested that the simulation showed that due to bending created by the force on the toilet bowl, both surfaces contacted the support structure. However, the simulation assumed that a force of 500 pounds was placed on the toilet bowl, significantly more force than would be encountered in a real-world situation. (Meyers Decl. Ex. B Appx. C, Part 1 of 3, 24-26.) Plaintiff's finite element analysis simulation does not create a genuine dispute of material fact: again, the first surface cannot be the claimed flange.

Alternatively, there is another reason that the first surface cannot be the claimed flange. In order to infringe, the flange must be "supported by the top of the support structure." If we read "flange" to refer to the first surface, the question remains whether each surface transfers loads to the "top of the support structure" as required by the claim language. (See Def.'s Mem. P. & A. 11 n.5.) As discussed above, the Court presumes that both surfaces rest on the support structure for the purpose of this summary judgment motion, with the second surface sitting above the first surface. If both surfaces are resting on the support structure, and the second surface touches the top of the support structure, the first surface would not touch the top of the structure. Rather, because the first surface is below the second surface, it would touch an intermediate point on the support structure. For this reason, the first surface cannot rest on the *top* of the support structure as required by the claim language. The Court, therefore, need only analyze the second surface.

It is clear from Figures 2 and 3 that the second surface is a slot within a series of cylindrical columns or "ribs" extending vertically, not part of a flat "edge" or "rim." Instead of a flat horizontal piece sticking out, the entire set of ribs rests on the support structure. In light of the claim construction order, a surface that is a "rib" cannot literally constitute a flange. (See Markman Order 8.) Thus, the second surface cannot literally be a "flange." Accordingly, the Court finds that there is no literal infringement of the '942 Patent.

---

<sup>1</sup> Both parties object to the late disclosure of evidence relevant to this issue. (See Def.'s Mem. P & A 10 n. 4; Pl.'s Opp'n 10 n.4.) The Court declines to strike or exclude the evidence at this stage of the proceedings.

#12087  
**UNITED STATES DISTRICT COURT  
 CENTRAL DISTRICT OF CALIFORNIA**

Priority \_\_\_\_\_  
 Send \_\_\_\_\_  
 Enter \_\_\_\_\_  
 Closed \_\_\_\_\_  
 JS-5/JS-6 \_\_\_\_\_  
 Scan Only \_\_\_\_\_

**CIVIL MINUTES - GENERAL**

**CASE NO.:** CV 13-06089 SJO (FFMx)

**DATE:** January 23, 2015

In the absence of literal infringement, Plaintiff argues that the surfaces are instead flanges under the doctrine of equivalents. (Pl.'s Opp'n 11.) Defendant responds that Plaintiff cannot argue the doctrine of equivalents for two reasons: (1) the Court has already ruled that ribs do not satisfy the "flange" limitation; and (2) prosecution history estoppel bars a patent owner from recapturing subject matter that was surrendered to acquire the patent. (Def.'s Mem. P. & A. 12.) Defendant's first argument fails, as the doctrine of equivalents is not a binary exercise: just because a rib is not a "flange" does not mean it inherently cannot perform a substantially similar function in a substantially similar way to achieve a substantially similar result. *See Deere & Co. v. Bush Hog, LLC*, 703 F.3d 1349, 1356 (Fed. Cir. 2012) ("Courts should be cautious not to shortcut this inquiry by identifying a 'binary' choice in which an element is either present or 'not present.'").

Defendant's second argument is more persuasive. The phrase "out-turned flange supported by the top of the support structure" was added during prosecution to distinguish the claims from U.S. Patent No. 5,604,938 ("Tyler"). Under *Festo*, this creates a presumption "that the patentee surrendered all subject matter between the broader and the narrower language." *Festo VIII*, 535 U.S. at 740. Plaintiff argues that the "tangential relation" exception applies. To rebut the presumption, a patentee must demonstrate that "the rationale underlying the amendment bore no more than a tangential relation to the equivalent in question," or, in other words, that "the narrowing amendment was peripheral, or not directly relevant, to the alleged equivalent." *Honeywell Intern., Inc. v. Hamilton Sundstrand Corp.*, 523 F.3d 1304, 1315 (Fed. Cir. 2008) (quoting *Festo IX*, 344 F.3d at 1369). However, "[t]he tangential relation criterion for overcoming the *Festo* presumption is very narrow." *Honeywell*, 523 F.3d at 1315 (citing *Cross Med. Prods., Inc. v. Medtronic Sofamor Danek, Inc.*, 480 F.3d 1335, 1342 (Fed. Cir. 2007)). "The tangential relation criterion focuses on the patentee's objectively apparent reason for the narrowing amendment." *Honeywell*, 523 F.3d at 1315 (quoting *Festo IX*, 344 F.3d at 1369). The reason for the narrowing amendment "should be discernible from the prosecution history record. . . ." *Id.*

Here, the amendment was made to distinguish from the Tyler patent, a toilet with a different support mechanism. (See Pl.'s Statement of Genuine Disputes ¶ 57.) The applicants added a specific type of support mechanism to the claim to "avoid the application of prior art." (Pl.'s Statement of Genuine Disputes ¶ 59.) Defendant's toilets have yet another, slightly different, kind of support: they use ribs instead of flanges. Given how narrow the tangential relation exception is, and considering that the narrowing amendment was directly related to the physical elements that support the toilet bowl, the Court concludes that the tangential relation exception does not apply. Accordingly, Plaintiff is estopped from arguing the doctrine of equivalents on this issue.

Since neither the first nor second surfaces literally constitute "an out-turned flange supported by the top of the support structure," and because Plaintiff cannot argue the doctrine of equivalents, the Court finds that Defendant does not infringe the asserted claims of the '942 Patent. Accordingly, the Court **GRANTS** summary judgment of noninfringement of the asserted claims of the '942 Patent.

UNITED STATES DISTRICT COURT  
CENTRAL DISTRICT OF CALIFORNIA

Priority \_\_\_\_\_  
Send \_\_\_\_\_  
Enter \_\_\_\_\_  
Closed \_\_\_\_\_  
JS-5/JS-6 \_\_\_\_\_  
Scan Only \_\_\_\_\_

CIVIL MINUTES - GENERAL

CASE NO.: CV 13-06089 SJO (FFMx)

DATE: January 23, 2015

3. '055 Patent - Line Replaceable Unit

Defendant seeks summary judgment that it does not infringe the asserted claims of the '055 Patent. Defendant contends that there can be no genuine dispute that the B/E toilet does not provide "a valve set forming a . . . second line replaceable unit." (Def.'s Mem. P. & A. 13.) The Court previously construed the phrase "line replaceable unit," found in Claims 1 and 15 of the '055 Patent, to mean "a single module targeted for easy replacement in the field." (Markman Order 16.)

Plaintiff argues that Defendant's toilets include a discharge valve and flush control unit ("FCU" or "ISC") that form a valve set, and that this valve set is a line replaceable unit ("LRU"). Defendant provides two arguments for noninfringement: (1) Defendant's toilet does not have a "valve set," and (2) the components identified by Plaintiff as a valve set are not an LRU. (Def.'s Mem. P. & A. 13-16.) The Court addresses each argument in turn.

i. Valve Set

Defendant argues that the discharge valve and ISC do not form a "valve set" because the two components are separately bolted into a rear support structure, there is no evidence that these parts have been provided as a set by B/E, and there is no evidence that any customers have ever replaced the two components together. (Def.'s Mem. P. & A. 13-15.) Plaintiff responds that B/E documentation specifically mentions that the "ISC is mounted to the flush valve." (See, e.g., Meyers Decl. Ex. B. ¶ 3.142.) Defendant also claims that during prosecution, the applicants explicitly distinguished "separately and independently mounted" components of the prior art as not forming a valve set. (Def.'s Mem. P. & A. 14.)

Prosecution disclaimer precludes patentees "from recapturing through claim interpretation specific meanings disclaimed during prosecution." *Omega Eng'g, Inc. v. Raytek Corp.*, 334 F.3d 1314, 1323 (Fed. Cir. 2003) (citation omitted). "[W]here the patentee has unequivocally disavowed a certain meaning to obtain his patent, the doctrine of prosecution disclaimer attaches and narrows the ordinary meaning of the claim congruent with the scope of the surrender." *Id.* at 1324. But the doctrine does not apply "where the alleged disavowal of claim scope is ambiguous." *Id.*

Here, the inventors stated that the prior art "fails to disclose or suggest a toilet having a valve set as a line replaceable unit," instead disclosing "a vacuum toilet having a separately mounted rinse solenoid valve, flush valve assembly, and timer/electronic module. . . ." (Mosley Decl. Ex. D 133.) The inventors go on to explain how each of these components is mounted to a very different part of the toilet: one component is mounted on the discharge pipe, one is mounted in between the legs on the base of the toilet, and one is attached to the rear of the support base. (Mosley Decl. Ex. D 133.) This is sufficient to disclaim a design where each component of the valve set is attached to a different part of the toilet. However, it does not unambiguously disclaim designs like

UNITED STATES DISTRICT COURT  
CENTRAL DISTRICT OF CALIFORNIA

Priority \_\_\_\_\_  
Send \_\_\_\_\_  
Enter \_\_\_\_\_  
Closed \_\_\_\_\_  
JS-5/JS-6 \_\_\_\_\_  
Scan Only \_\_\_\_\_

CIVIL MINUTES - GENERAL

CASE NO.: CV 13-06089 SJO (FFMx)

DATE: January 23, 2015

Defendant's where all the valve set components are attached to a single, removable piece. Because there is not an unambiguous disclaimer of claim scope broad enough to include the features of Defendant's design, the doctrine of prosecution disclaimer does not apply here.

Further, Plaintiff has provided evidence that the "ISC is mounted to the flush valve." (Meyers Decl. Ex. B. ¶ 3.142.) This evidence includes B/E documents that show a small, separate rear support that locks into the rest of the toilet support structure, collectively labeled "Flush Valve." (Meyers Decl. Ex. B. ¶ 3.140.) It also includes photographs depicting the removal of the discharge valve and ISC together as a single component. (Meyers Decl. Ex. B. Appx. C, Part 2 of 3 48-54.) It includes expert testimony that these components form a valve set that can be easily removed as a single component. (Mosley Decl. Ex. AT, Meyers Dep. 212:23-214:17.) As we must resolve any reasonable factual inferences in favor of the nonmoving party, the Court finds that there is a genuine issue of disputed material fact regarding whether the discharge valve and ISC form a valve set, and so Defendant cannot obtain summary judgment of noninfringement on this ground.

ii. Line Replaceable Unit

The second issue is whether the valve set is a "line replaceable unit" - that is, whether it is a single module targeted for easy replacement in the field. Plaintiff points to a training video which shows the flush valve and ISC being removed together during disassembly of the entire toilet but does not appear to explicitly identify the flush valve unit. (Statement of Genuine Disputes ¶ 77-78; Mosley Decl. Ex. AG, BE-MAG-001-0237050, at -237062.) In response, Defendant asserts that all B/E documents that describe the removal of the flush valve and the ISC explicitly describe removal of the two components separately, with the ISC being removed before the flush valve. (Statement of Genuine Disputes ¶ 81-82.) Plaintiff cites only the training video as a counterexample. (Statement of Genuine Disputes ¶ 81-82.)

Plaintiff admits that B/E's Component Maintenance Manuals do not provide instructions for removing and replacing the flush valve and flush control unit as an LRU. (Statement of Genuine Disputes ¶ 73.) It is undisputed that MAG is unaware that the flush valve and ISC have ever been removed at the same time by a customer. (Statement of Genuine Disputes ¶ 74.) It is undisputed that B/E does not sell or offer the flush valve and ISC together as a single unit or set and that each has a separate part number. (Statement of Genuine Disputes ¶¶ 67-68.) Given all these facts, it is unreasonable to infer that the flush valve and ISC are a unit targeted for easy replacement in the field. A disassembly video of an entire toilet which does not appear to explicitly refer to the flush valve or suggest replacement of the flush valve is not sufficient to create a genuine issue of disputed material fact. Accordingly, the Court finds that a "line replaceable unit" as recited by the claims of the '055 Patent is not present in Defendant's toilet, and the Court **GRANTS** summary judgment of noninfringement for the asserted claims of the '055 Patent.

4. '942 and '055 Patents - Performance Within the United States

UNITED STATES DISTRICT COURT  
CENTRAL DISTRICT OF CALIFORNIA

Priority \_\_\_\_\_  
Send \_\_\_\_\_  
Enter \_\_\_\_\_  
Closed \_\_\_\_\_  
JS-5/JS-6 \_\_\_\_\_  
Scan Only \_\_\_\_\_

CIVIL MINUTES - GENERAL

CASE NO.: CV 13-06089 SJO (FFMx)

DATE: January 23, 2015

Defendant seeks summary judgment that it does not infringe the asserted claims of the '055 Patent or claim 14 of the '942 Patent. Defendant contends that Plaintiff cannot prove that anyone, including B/E, performed the claimed methods within the United States. (Def.'s Mem. P. & A. 17-19.) Plaintiff responds that there is evidence that both Defendant and United Airlines have performed the claimed methods by replacing toilet bowls and that Defendant is also liable for indirect infringement because its technical manuals instruct customers how to remove the toilet bowl independently of the frame. (Pl.'s Opp'n 16-18.) While, as discussed above, there is no infringement because of the "valve set" and "flange" language in the '055 and '942 patents respectively, the Court addresses this issue for the sake of completeness.

First, there is no requirement in the claims that infringement take place aboard an aircraft. The method claims of the '055 patent do require replacement "independently of the toilet," and a line replaceable unit is construed as "a single module targeted for easy replacement in the field." (Markman Order 16.) However, there is no particular requirement that replacement take place aboard an aircraft, so long as the module is *targeted* for easy replacement in the field, and for the '055 patent, so long as replacement occurs independently of the toilet. Thus, even if an LRU was replaced while a toilet was in a maintenance shop, that would suffice for infringement.

Plaintiff has provided evidence that Defendant has replaced vacuum toilet bowls at least a dozen times, due to a widespread problem with older, lighter-colored bowls developing coffee stains. (Meyers Decl., Ex. B, Appx. C, Part 1 of 3, 71-73; Part 2 of 3, 68-70.) This is evidence that Defendant has performed the claimed methods within the United States.

With respect to indirect infringement, Plaintiff must show that a third party has directly infringed within the United States. See *Limelight Networks, Inc. v. Akamai Techs., Inc.*, 134 S. Ct. 2111, 2117 (2014). Plaintiff has produced sufficient evidence for a jury to find that United has performed the claimed methods within the United States. There is evidence that United has replaced a toilet bowl, and as discussed above, it does not matter whether this replacement took place on an aircraft. (Mosley Decl. Ex. AU, Peters Dep. 161:2-6.) As United is an airline based in the United States with the majority of its operations in the United States, a reasonable jury could find that United's replacement of a toilet bowl took place within the United States.

Further, Plaintiff has provided evidence that Defendant instructed United regarding toilet bowl replacement. (See Mosley Decl. Ex. AU, Peters Dep. 161:2-6, 175:8-18, 183:8-185:6, 190:12-16, 215:7-21; Mosley Decl. Ex. AG, BE-MAG-001-0237050, at -237069; Meyers Decl. Ex. B ¶¶ 3.3; 3.159.) This evidence would be sufficient for a jury to find indirect infringement. Accordingly, the court declines to grant summary judgment of noninfringement on the grounds that the claimed methods were not performed within the United States.

UNITED STATES DISTRICT COURT  
CENTRAL DISTRICT OF CALIFORNIA

CIVIL MINUTES - GENERAL

CASE NO.: CV 13-06089 SJO (FFMx)

DATE: January 23, 2015

"The court in exceptional cases may award reasonable attorney fees to the prevailing party." 35 U.S.C. § 285. After reviewing the relevant facts, the Court concludes that this is not an exceptional case that would warrant an award of attorney fees.

IV. RULING

Plaintiff's Motion for Summary Judgment as to Assignor Estoppel is hereby **GRANTED**. Defendant's Motion for Summary Judgment of Noninfringement and Invalidity is hereby **GRANTED IN PART AND DENIED IN PART**, as follows:

1. Defendant has not directly or indirectly infringed claims 13, 14, 18, 19, and 22-24 of United States Patent No. 6,353,942;
2. Defendant has not directly or indirectly infringed claims 15, 16, 20, 21, and 24-26 of United States Patent No. 6,536,055;
3. Defendant has not directly or indirectly infringed claims 1, 4-7, and 9 of United States Patent No. 6,536,054;
4. In view of the fact that MAG Aerospace Industries, Inc. has withdrawn its infringement allegations concerning these claims, has not presented any evidence of infringement on these claims, and for other reasons as demonstrated in its motion, B/E Aerospace, Inc. has not directly or indirectly infringed claims 10, 12-15, and 17 of United States Patent No. 6,536,054.
5. Defendant's invalidity claims are **DENIED**.

The trial, pretrial, and all other hearing dates previously set by the Court are vacated and set aside.

IT IS SO ORDERED.