

NOTE: This disposition is nonprecedential.

**United States Court of Appeals
for the Federal Circuit**

JEAN MELCHIOR,
Plaintiff-Appellee

**BORGWARNER, INC.,
BORGWARNER MORSE TEC INC.,**
Third Party Defendants

v.

HILITE INTERNATIONAL, INC.,
Defendant-Appellant

2015-1932

Appeal from the United States District Court for the Northern District of Texas in No. 3:11-cv-03094-M, Judge Barbara M.G. Lynn.

Decided: December 12, 2016

STEVEN DOMINIC SANFELIPPO, Cunningham Swaim, LLP, Dallas, TX, argued for plaintiff-appellee. Also represented by MICHAEL ROSS CUNNINGHAM, THOMAS C. WRIGHT.

JOHN DIMATTEO, Holwell Shuster & Goldberg LLP, New York, NY, argued for defendant-appellant. Also represented by DANIEL MARTIN SULLIVAN; JOHN C. EICHMAN, Hunton & Williams LLP, Dallas, TX.

Before NEWMAN, CLEVINGER, and DYK,
Circuit Judges.

Opinion for the court filed by *Circuit Judge* DYK.

Opinion concurring in the judgment of
no liability filed by *Circuit Judge* NEWMAN.

DYK, *Circuit Judge.*

Jean Melchior sued Hilite International, Inc. for infringing certain claims of U.S. Patent Nos. 5,645,017 (“the ’017 patent”), 5,649,506 (“the ’506 patent”), and 5,507,254 (“the ’254 patent”). Following a jury trial and verdict in favor of Melchior, the district court denied Hilite’s motion for judgment as a matter of law of noninfringement and invalidity, and ordered judgment for Melchior. Because we hold that the district court should have found the asserted patent claims invalid, we *reverse*.

BACKGROUND

I

Because we reach only the issue of invalidity, we have correspondingly limited our recitation of the facts. In a typical internal combustion engine, the explosive forces generated by the combustion of fuel in the engine’s cylinders are translated by pistons into the rotation of a crankshaft. The rotation of the crankshaft is linked by a timing chain to the rotation of one or more camshafts, which in turn controls the opening and closing of the cylinders’ intake and exhaust valves. The opening and closing of the valves permits fuel to enter the cylinders and the combustion byproducts to leave.

A camshaft controls the opening and closing of the intake and exhaust valves through cams, which are lobular protrusions having a particular arrangement along the axis of the camshaft. As the camshaft rotates, a cam opens a valve by coming into physical contact with the valve and pushing it open. As the camshaft rotates the cam away, the valve springs back into a closed position as the cam loses physical contact. The arrangement of cams and the rotation of the camshaft, together, ultimately control the precise timing of the valves' opening and closing.

Well before the filing of the patents-in-suit, it was discovered that engine performance could be optimized if the intake or exhaust valves could, at certain times, open or close sooner or later than they otherwise would. This principle is known as variable valve timing. One way of achieving variable valve timing is through the use of cam phasers, the technology at the center of this case. A cam phaser alters valve timing by rotating the camshaft to be out of "phase" with the crankshaft. The "phase" or "phase difference" between the camshaft and the crankshaft is equivalent to the relative angle between the two. By "advancing" the camshaft (or increasing the phase), the cam phaser causes the valves to open earlier; by "retarding" the camshaft (or decreasing the phase), the cam phaser causes the valves to open later.

The cam phasers disclosed in the asserted patents are hydraulic components that operate by filling and draining two coupled hydraulic chambers. By filling one chamber with an incompressible hydraulic fluid (e.g., oil) and draining the other, the phasers cause the camshaft to either advance or retard. By preventing either chamber from filling or draining, the phasers cause the camshaft's phase to remain constant. These aspects of the cam phasers covered by the patents were known in the prior art.

It was also known in the prior art that a phaser's hydraulic chambers could be filled using a pump. *See, e.g.*, '017 patent, col. 1 ll. 38–40. The claimed innovation disclosed in Melchior's patents is a cam phaser capable of filling its chambers without a pump. Instead of a pump, Melchior's phaser takes advantage of a phenomenon known as a "torque reversal" that generates alternating differences in pressure between the chambers.¹ The asserted claims are drawn to methods and internal combustion engines that use these pressure differentials to force fluid out of one chamber and into the other. Claim 22 of the '017 patent and claim 5 of the '254 patent, for instance, are drawn to methods that recite "varying the position" of the camshaft by "actuating" the hydraulic chambers "in reaction to torque reversals." '017 patent, col. 12 ll. 19–34; '254 patent, col. 19 l. 52–col. 20 l. 15. Claim 7 of the '506 patent similarly provides for an internal combustion engine having a cam phaser with "flow control means . . . operable to be reactive to torque reversals." *See* '506 patent, col. 11 ll. 28–53.

The use of torque reversals is further illustrated by an embodiment of Melchior's phaser shown in figure 3 of the '017 patent, reproduced below.

¹ A torque reversal refers to the pair of forces acting on the camshaft as a cam comes into contact with a valve. As the cam pushes the valve open, it experiences a "pulse" caused by resistance from compressing the valve's return spring. Then, as the valve closes and the cam moves away, the spring's extension creates another "pulse" in the opposite direction.

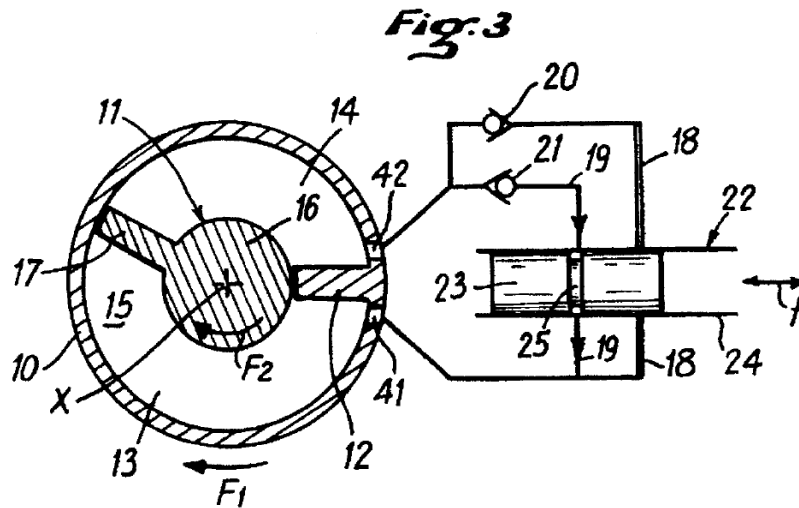

As shown in figure 3, chambers 13 and 14 are “inter-connected by two unidirectional [hydraulic] communication [hydraulic] circuits 18 and 19 of opposite directions owing to the presence of check valves 20 and 21.” ’017 patent, col. 3 ll. 45–50. By appropriately positioning slide 23, one of the circuits can selectively be opened by being aligned with groove 25—as shown in figure 3, circuit 19 is open. ’017 patent, col. 3 ll. 60–67. Once a circuit is opened, the hydraulic fluid in one chamber is able to move down the pressure gradient generated by a torque reversal, through the circuit, and into the other chamber. ’017 patent, col. 4, ll. 23–43. Flow in the opposite direction (back into the first chamber) is prevented by the presence of the corresponding check valve. Accordingly, by using Melchior’s phaser, it is “possible to vary in operation the phase between the [crankshaft] and the [camshaft] without use of a power means such as a source of fluid under pressure,” *i.e.*, a pump. ’017 patent, col. 1, ll. 48–49.

II

Melchior sued Hilite in the United States District Court for the Northern District of Texas alleging, *inter alia*, infringement of claims 22–25 of the '017 patent; claims 7–10, 12–15, and 18 of the '506 patent; and claim 5 of the '254 patent. Melchior asserted that two of Hilite's phasers, the "Fast Phaser" and the "Fam-B OCV," infringed the asserted claims because each phaser, despite generally using a pump to advance and/or retard the camshaft's phase, was also designed to vary the phase *without* the pump at certain points of the accused phaser's operation using torque reversals.² J.A. 10. Hilite defended by arguing that its phasers did not infringe, and that the claims were invalid as, *inter alia*, anticipated by Danckert, a German patent, or rendered obvious by Danckert in view of Shirai, U.S. Patent No. 4,858,572. Danckert was published in 1986, before the priority date of Melchior's patents, and is titled "Device for Load and Speed Dependent Adjustment of the Timing of a Gas Exchange Valve of an Internal Combustion Engine." Shirai has a U.S. filing date that antedates Melchior's priority date and is titled "Device for Adjusting an Angular Phase Difference Between Two Elements."

Melchior and Hilite's respective claims of infringement and invalidity were heard before a jury in February 2015. The jury returned a verdict finding that Hilite's phasers infringed the asserted claims and that the claims were not invalid. Hilite then filed a renewed motion for judgment as a matter of law ("JMOL"), which the district court denied. This appeal followed.

² The parties stipulated that "there is no infringement at any moment in time during which the pump is supplying oil to the phaser chambers . . . even when assisted by" torque reversals. J.A. 5709.

DISCUSSION

I

We have jurisdiction under 28 U.S.C. § 1295. We review the district court's denial of a motion for JMOL *de novo*. See *Nobach v. Woodland Village Nursing Center, Inc.*, 799 F.3d 374, 377 (5th Cir. 2015). Accordingly, we will uphold the jury's verdict as long as it is supported by substantial evidence. See *Z4 Techs., Inc. v. Microsoft Corp.*, 507 F.3d 1340, 1346 (Fed. Cir. 2007) (quoting *Lane V. R.A. Sims, Jr., Inc.*, 241 F.3d 439, 445 (5th Cir. 2001)).

II

Anticipation as a defense to infringement requires proof by "clear and convincing evidence that a single prior art reference discloses each and every element of [the] claimed invention." *K-TEC, Inc. v. Vita-Mix Corp.*, 696 F.3d 1364, 1377 (Fed. Cir. 2012). Hilite maintains that this standard is met by Danckert, and that no reasonable jury could have concluded otherwise on the trial record.

Hilite has offered claim 22 of the '017 patent as representative on appeal, and Melchior does not disagree. Claim 22 provides:

22. In an internal combustion engine having a crankshaft, at least one camshaft, the at least one camshaft being position variable relative to the crankshaft and being subject to torque reversals, the method comprising:

providing oppositely acting first and second hydraulic means for varying the position of the at least one camshaft;

varying the position of the at least one camshaft relative to the crankshaft by transferring hydraulic fluid from one of the first and second hydraulic means to

the other of the first and second hydraulic means; and

actuating the first and second hydraulic means for varying the position of the at least one camshaft relative to the crankshaft in reaction to torque reversals in the at least one camshaft.

'017 patent, col. 12 ll. 19–34.

Danckert teaches a “device for load and speed dependent adjustment of the timing of a gas exchange valve”—*i.e.*, a cam phaser—for which “no additional energy sources are necessary for the adjustment.” J.A. 15715. Danckert renders these “additional energy sources” unnecessary by using “alternative torques generated by the internal combustion during propulsion,” *i.e.*, torque reversals, “for the adjustment of the cam mechanism.” *Id.* Like the other phasers at issue in this case, Danckert’s phaser employs two hydraulic chambers; when a “control piston is displaced,” one chamber is “opened . . . and connected via [] connecting lines to the pressurizing medium inlet or outlet, while at the same time . . . the [other] chamber” is “seal[ed].” J.A. 15720 (figure reference numbers omitted). As a consequence of the “locking” of one chamber, the “simultaneous opening” of the other, and the “axial forces” acting on Danckert’s phaser, a “set piston” between the chambers is adjusted by the “escape” of “[p]ressurizing medium” (oil) from the open chamber into the connecting lines, while “at the same time,” pressurizing medium from the connecting lines “can be filled” into the sealed chamber. *Id.*

At trial, Melchior’s invalidity expert conceded that Danckert satisfied all but one of the recited limitations of claim 22. Specifically, he agreed that: (1) “Danckert discloses an internal combustion engine having a crankshaft and at least one camshaft”; (2) “the at least one camshaft is positioned variable relative to the crankshaft”

and “is subject to torque reversals”; (3) “Danckert discloses oppositely acting first and second hydraulic means”; (4) “Danckert describes actuating the first and second hydraulic means for varying the position of the camshaft relative to the crankshaft”; (5) “[a]nd that [the] actuation is done in reaction to torque reversal[s].” J.A. 7596–98. The only limitation remaining in claim 22 is “transferring hydraulic fluid from one of the first and second hydraulic means to the other of the first and second hydraulic means.” With respect to this limitation, Melchior’s expert agreed that the “only thing [he] dispute[d] . . . with all the claims relative to Danckert, [was] whether the transfer of fluid is a . . . direct transfer in a closed line.” J.A. 7599. According to the expert, Danckert failed to satisfy “direct transfer in a closed line” because the reference “opened” the circuit between the hydraulic chambers to a “central cavity which acts as a sump.” *Id.*; *see also* J.A. 7581 (“The Danckert teachings have two chambers that are not directly connected, providing a closed-loop connection between the chambers. Instead the two chambers are connected to central cavity that is open to the pressure source.”).

The problem with distinguishing Danckert on the basis Melchior’s expert asserted is that the claims do not require “direct transfer in a closed line.” Neither these words nor any approximation thereof appears in representative claim 22, a point which the expert readily conceded. *See* J.A. 7599–600 (“Q. . . . Where in the claims do you see, quote, direct transfer . . . [c]lose quote. . . . A. I don’t see that.”). Melchior also never requested the district court to construe the “transferring” step of claim 22 to require “direct transfer in a closed line.” To the contrary, Melchior requested a much broader construction that the district court ultimately adopted.³ *See, e.g.,* Joint

³ *See* J.A. 4388. In accordance with Melchior’s proposed claim construction, the district court construed the

Claim Construction and Prehearing Statement Exhibit B at 4–5, *Melchior v. Hilite Int’l, Inc.*, No. 3:11-cv-03094-M (N.D. Tex. Aug. 30, 2012), ECF No. 39-1. Nor did the district court adopt any construction that, or instruct the jury that, “direct transfer in a closed line” was otherwise a required claim limitation.

There is also no support for such a construction in the patents’ specification. Melchior does not contend that “direct transfer in a closed line” appears in the patents’ specifications, nor has he identified any portion of the patents’ prosecution history that would support reading in this limitation. Instead, he argues that the specifications “contemplate a direct transfer of fluid from one phaser chamber to the other in a closed circuit” because the “Summary of the Invention” sections of the asserted patents state that “increasing the volume of one or the other of the[] chambers and correlatively decreasing the volume of the opposite chamber . . . is accomplished with the joint action of the unidirectional communication circuits and distribution means, which thereby vary the phase difference . . . by an *exchange* of hydraulic liquid between the two chambers.” ’017 patent, col. 2 ll. 4–10 (emphasis added); *see also* ’506 patent, col. 2 ll. 7–13; ’254 patent, col. 2 ll. 17–21. This language, however, is hardly tantamount to “direct transfer in a closed line.”

Melchior further argues that a statement made in the district court’s *Markman* order explaining its construction of a *different* claim term supports reading claim 22 to require “direct transfer in a closed line.” Specifically, regarding its construction of the limitation “oppositely acting . . . hydraulic means,” the district court explained that “[a] phase shift occurs when there is a direct transfer of hydraulic fluid from one chamber to another.” J.A.

“transferring” step to mean “permitting fluid to flow out of one hydraulic means and into the other oppositely acting hydraulic means.” *Id.*

4388. But the fact that the district court in explanation referred to a “direct transfer” in construing another claim term does not render it a claim limitation, or part of the court’s claim construction. Melchior’s expert also conceded that the words “direct transfer” do not appear in the district court’s claim construction, and that his testimony relied only on his “interpretation of the [c]ourt’s construction.” J.A. 7600–01. And critically, the explanations in the district court’s *Markman* order—including the reference to “direct transfer”—were never given to the jury.⁴

⁴ For the first time at oral argument, Melchior’s counsel argued that the district court’s construction of two means-plus-function limitations in claims 23 and 25 of the ’017 patent supported reading the claims to require direct transfer in a closed line. *See* Oral Argument at 28:30, *Melchior v. Hilite Int’l, Inc.*, No. 15-1932 (Fed. Cir. Oct. 3, 2016), *available at* <http://oralarguments.cafc.uscourts.gov/default.aspx?fl=2015-1932.mp3>. The district court construed “valve means for selectively permitting flow out of one or another of the first and second hydraulic means into an inlet line leading to the other of the first and second hydraulic means,” and “check valve means in the inlet line for permitting hydraulic fluid to flow therethrough only into the other of the first and second hydraulic means.” ’017 patent, col. 12 ll. 40–46, col.13, ll. 4–10. The district court concluded that the structure for the former was the “necessary connection comprising [a] communication circuit and [a] check valve,” and that the function for the latter was to “[p]ermit[] hydraulic fluid to flow . . . *only* into the other of the first and second hydraulic means.” J.A. 4390 (emphasis added).

Melchior’s new argument is waived. *See James v. Santella*, 328 F.3d 1374, 1383–84 (Fed. Cir. 2003). Melchior has agreed that claim 22 of the ’017 patent is representative, and has never suggested that claims 23 and 25 are materially distinguishable from claim 22 for the

Our cases establish that prior art cannot be distinguished on the ground that it lacks features that are not claim limitations. *See, e.g., DDR Holdings, LLC, v. Hotels.com, L.P.*, 773 F.3d 1245, 1252–54 (Fed. Cir. 2014) (“Anticipation challenges under § 102 must focus only on the limitations *actually recited in the claims.*” (emphasis added)); *In re Gleave*, 560 F.3d 1331, 1336 (Fed. Cir. 2009) (“[W]here the claims themselves do not require a particular activity, we have no call to require something more from the anticipating reference.”); *Verdegaal Bros. v. Union Oil Co. of Cal.*, 814 F.2d 628, 632 (Fed. Cir. 1987) (“[T]here is no limitation in the subject claims with respect to the rate at which sulfuric acid is added, and, therefore, it is inappropriate for Verdegaal to rely on that distinction.”). Here, Melchior has conceded that Danckert satisfies all limitations of claim 22, except for one feature that we have concluded is not a claim limitation. Accordingly, the jury’s verdict of no anticipation cannot stand because it is not supported by substantial evidence. *See, e.g., DDR Holdings*, 773 F.3d at 1254–55; *see also, e.g., Ecolab, Inc. v. FMC Corp.*, 569 F.3d 1335, 1348 (Fed. Cir. 2009); *Akamai Techs., Inc. v. Cable & Wireless Internet Servs., Inc.*, 344 F.3d 1186, 1193–94 (Fed. Cir. 2003).

III

On appeal, the parties have treated the issue of invalidity as to all asserted claims as turning solely on whether claim 22 is anticipated by Danckert, and properly so.

purpose of anticipation; Melchior’s invalidity expert, moreover, never relied on the limitations in claims 23 and 25 to overcome Danckert. Even if this argument were not waived, the district court’s construction does not read the claims to require “direct transfer in a closed line.” The district court’s construction simply constrains the “valve means” or “check valve means” to structures that “selectively” permit flow “only” in one direction instead of back into the original chamber.

However, at trial, the defense of anticipation was limited to claims 22–25 of the '017 patent. With respect to the remaining asserted claims of the '506 and '254 patents, the issue is whether those claims would have been obvious over Danckert in view of Shirai.

Like claims 22–25 of the '017 patent, the asserted claims of the '506 and '254 patents require hydraulic components that are “reactive to” or “actuat[ed] . . . in reaction to . . . torque reversals.” '506 patent, col. 11 ll. 47–53, col. 12 ll. 44–50, col. 14 ll. 3; '254 patent, col. 20 ll. 12–15. But these claims are not anticipated by Danckert because claims 7–10, 12–15, and 18 of the '506 patent further require, in relevant part, “a housing . . . rotatable with” the camshaft and “having at least one recess . . . defining a fluid receiving chamber and receiving therein at least one lobe . . . oscillatable within [the] at least one recess,” and “rotary movement transmitting means for transmitting rotary movement from the crankshaft.” '506 patent, col. 11 ll. 38–47, col. 12 ll. 33–43, col. 13 ll. 49–57. Claim 5 of the '254 patent additionally recites “first and second hydraulic chambers” that are “subdivided . . . into subchambers complementary in volume to each other.” '254 patent, col. 19 ll. 54–65.

As Hilite’s invalidity expert succinctly summarized, the difference between the '506 patent claims and Danckert is that the former are drawn to a “rotary” cam phaser, while the latter discloses only a “linear” cam phaser. Transcript of Jury Trial, Volume 4, at 271, *Melchior v. Hilite Int’l, Inc.*, No. 3:11-cv-03094-M (N.D. Tex. Feb. 24, 2015), ECF No. 278. Similarly, claim 5 of the '254 patent requires “subchambers” instead of the pair of chambers taught by Danckert. *Id.* at 268–69. Hilite’s expert testified that these elements are all taught by Shirai, that it would be obvious for one of ordinary skill in the art to combine the teachings of Danckert with Shirai, and that the results would satisfy all limitations of the asserted claims in the '506 and '254 patents.

Melchior did not challenge Hilite's obviousness rationale at trial, nor has he done so on appeal. To the contrary, Melchior's expert conceded to the jury that, with respect to the '506 patent, "Melchior's invention is simply applying his circuit to [a] known configuration." Transcript of Jury Trial, Volume 5, at 145, *Melchior v. Hilite Int'l, Inc.*, No. 3:11-cv-03094-M (N.D. Tex. Feb. 25, 2015), ECF No. 279; *see also KSR Int'l Co. v. Teleflex Inc.*, 550 U.S. 398, 417 (2007). The only argument Melchior presented at trial against Hilite's invalidity defense of obviousness was that Danckert did not teach "direct transfer in a closed line," *i.e.*, that Danckert did not anticipate.

Accordingly, because Melchior's sole argument against obviousness was premised on a lack of anticipation, we conclude that the remaining claims are invalid as obvious over Danckert in view of Shirai, and that the jury's verdict of nonobviousness with respect to the remaining claims is not supported by substantial evidence. *See Leggett Platt & Inc. v. VUTEk Inc.*, 537 F.3d 1349, 1356 (Fed Cir. 2008). In light of our disposition, we decline to address any of the other issues raised in Hilite's appeal, including that the district court should have granted JMOL of noninfringement or otherwise erred in its claim construction.

CONCLUSION

The district court's denial of Hilite's motion for judgment as a matter of law is

REVERSED

NOTE: This disposition is nonprecedential.

**United States Court of Appeals
for the Federal Circuit**

JEAN MELCHIOR,
Plaintiff-Appellee

**BORGWARNER, INC.,
BORGWARNER MORSE TEC INC.,**
Third Party Defendants

v.

HILITE INTERNATIONAL, INC.,
Defendant-Appellant

2015-1932

Appeal from the United States District Court for the Northern District of Texas in No. 3:11-cv-03094-M, Judge Barbara M.G. Lynn.

NEWMAN, *Circuit Judge*, concurring in the judgment of no liability.

With all respect to the panel majority, I do not share the view that the claims, correctly construed, are invalid for anticipation. The jury verdict sustaining validity on this ground is supported by substantial evidence. Anticipation “requires the presence in a single prior art disclosure of all elements of a claimed invention arranged as in

the claim.” *Connell v. Sears, Roebuck & Co.*, 722 F.2d 1542, 1548 (Fed. Cir. 1983); *see also Therasense, Inc. v. Becton, Dickinson & Co.*, 593 F.3d 1325, 1332 (Fed. Cir. 2010); *SynQor, Inc. v. Artesyn Techs., Inc.*, 709 F.3d 1365, 1375 (Fed. Cir. 2013). The record contains sufficient evidence to support a jury finding that Danckert’s teaching of a central cavity connected to the pressure source did not anticipate the invention described and claimed in the Melchior patents.

However, the verdict of infringement is not supported by substantial evidence. By joint stipulation, both parties agreed that no infringement existed at any point in time when the external oil pump in the accused devices was operational. J.A. 5709. To support its infringement theory, Melchior had to present evidence establishing that the accused devices, in the fraction-of-a-second transition between hold and advance modes, operated contrary to design by sealing off the oil pump check valve. No such evidence appears on the record. All evidence of engine operation illustrates oil flowing through the pump valve, even during the transition mode described above.

On the basis that infringement was not established, I concur in the judgment of no liability.