

United States Court of Appeals for the Federal Circuit

2006-1276

BASS PRO TRADEMARKS, L.L.C.,

Plaintiff-Appellee,

v.

CABELA'S, INC.,

Defendant-Appellant.

JoAnn T. Sandifer, Husch & Eppenberger, LLC, of St. Louis, Missouri, argued for plaintiff-appellee.

Thomas I. Ross, Marshall, Gerstein & Borun LLP, of Chicago, Illinois, argued for defendant-appellant. With him on the brief was Matthew C. Nielsen.

Appealed from: United States District Court for the Western District of Missouri

Judge Richard E. Dorr

United States Court of Appeals for the Federal Circuit

2006-1276

BASS PRO TRADEMARKS, L.L.C.,

Plaintiff-Appellee,

v.

CABELA'S, INC.,

Defendant-Appellant.

DECIDED: APRIL 6, 2007

Before NEWMAN, Circuit Judge, CLEVINGER, Senior Circuit Judge, and DYK, Circuit Judge.

NEWMAN, Circuit Judge.

Cabela's, Inc. appeals the judgment of the United States District Court for the Western District of Missouri¹, holding Cabela's in civil contempt for violation of a settlement agreement and Consent Judgment resulting from a previous patent infringement suit. We

¹ Bass Pro Trademarks, L.L.C. v. Cabela's, Inc., No. 03-3124-CV-S-RED (W.D. Mo. Aug. 24, 2005).

conclude that Cabela's redesigned device could not reasonably be found to literally infringe the subject patent. We vacate the contempt order and accompanying sanctions.

DISCUSSION

Bass Pro Trademarks is the owner of United States Patent No. 5,620,227 (the '227 patent) entitled "Vest Garment With Pivotal Seat Member." Throughout the specification, and in all the claims, the patentee describes the invention as a combination of a vest and a folding seat. The "Description of the Invention" describes the "vest member 12" and the "front blouse members 18" of the vest; the "Background of the Invention" discusses "a wide variety of hunting vests which come equipped with several pockets and pouches" and states "[i]t would be desirable to incorporate a seat element into such types of garments"; and in the "Summary of the Invention" the patentee states the invention as follows:

By means of the instant invention there is provided a vest garment having a pivotable seat member. The vest garment is of the type commonly used for hunting, whose structure can approximate the conventional style of vest, or may have open shoulders to give more room and maneuverability to the user

. . . .

It is therefore an object of this invention to provide a vest garment having a seat member which can enable the vest to be utilized as a free-standing chair.

(Emphases added). All of the patent drawings show a vest structure: Patent Figure 1 is a perspective view of the vest 12 and front blouse 18 with the seat member 22 in position for use:

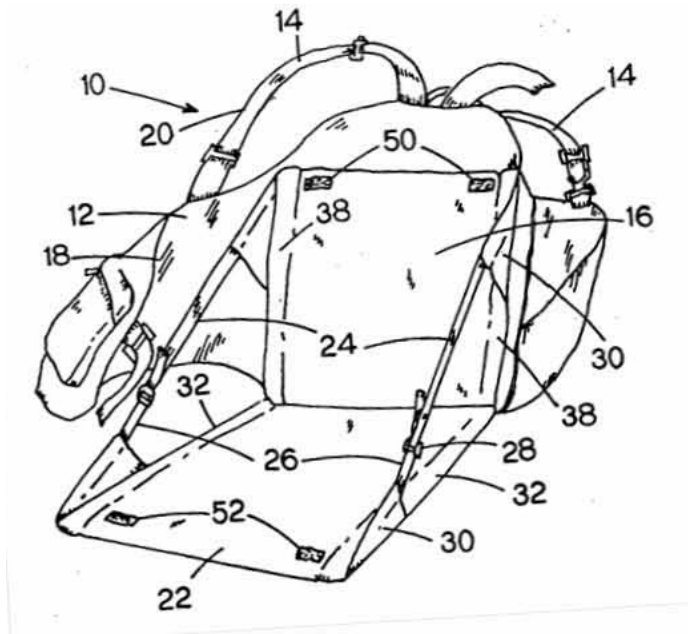

Fig. 1

Patent Figure 2 is a side elevation showing the seat 22 folded up against the vest 12 in a stowed position:

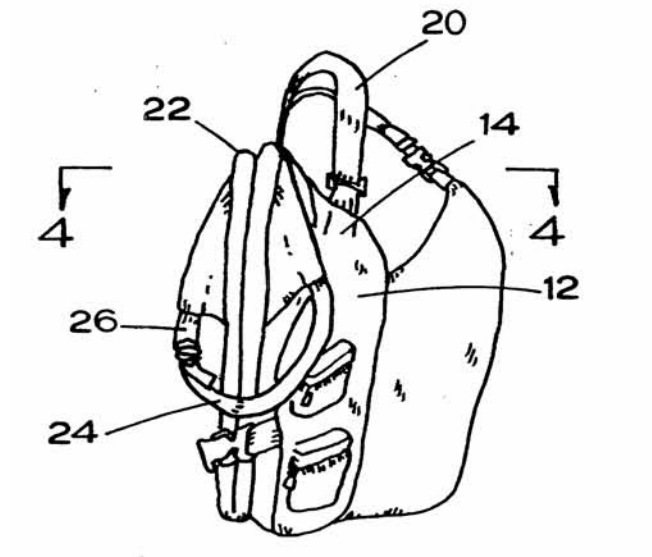

Fig. 2

During prosecution the patentee emphasized that the invention is the vest-seat combination. Claim 1, the broadest claim, follows:

1. A combination vest and pivotable seat member, said vest comprising a fabric to be worn on an upper torso of a user, said vest comprising at least a dorsal member and shoulder support means, said seat member having one end connected to a lower portion of said dorsal member and having straps for being connected to and supported from an upper portion of said dorsal member whereby an effective chair comprised of said seat member and said dorsal member for supporting said user is created, lengths of said straps being adjustable, whereby an angular orientation between said seat member and said dorsal member is adjustable.

In April 2003 Bass Pro charged Cabela's with infringement of the '227 patent, based on Cabela's "Stadium Seat Turkey Vest." Cabela's "Stadium Seat Turkey Vest" device is, without dispute, a combination of a vest and pivotable seat. Cabela's and Bass Pro entered into a settlement agreement embodied in a Consent Judgment, in which Cabela's admitted infringement and agreed to be permanently enjoined from future infringement. The Consent Judgment included Cabela's agreement that it

has infringed the Letters Patent by making and/or selling a stadium seat turkey vest with a pivotable seat member embodying the inventions claimed therein

and that

[Cabela's], its agents, employees, privies, successors, and assigns, are hereby permanently enjoined and restrained from the unauthorized making, using, selling or inducing others to use the inventions claimed in Letters Patent No. 5,620,227.

The district court entered the Consent Judgment on October 3, 2003, encompassing the agreement and final judgment.

A

About two years later Cabela's started to sell a device called the "EZ Chair Combo," which is described by Bass Pro as a folding seat attached to the back of a garment, and described by Cabela's as a folding seat held by backpack-type straps. The accused device is pictured in the record as follows:



It is not disputed that the EZ Chair Combo includes a pivotable seat with support consisting of adjustable straps and a fabric panel at the wearer's back. Bass Pro moved for contempt based on violation of the Consent Judgment. During the contempt hearing the district court construed the '227 claims as not limited to a traditional vest having a front blouse portion with pockets, stating that the prosecution history shows that "the invention was a garment that integrated a rigid seat into it -- not because the invention had a front blouse with

pockets." Bass Pro, slip op. at 7. The district court found that the EZ Chair Combo is a literal infringement of claim 1, and granted the contempt motion.

On appeal, Cabela's argues that its EZ Chair Combo is simply a pivotable seat carried by backpack-type straps. Cabela's states that claim 1, correctly construed, requires a vest as a full front-and-back garment, and that the specification and prosecution history stress the vest portion as a distinction from the prior art. Cabela's argues that the claim cannot be infringed by its use of shoulder straps and a strip of fabric on the wearer's back. Bass Pro responds that the term "vest" is limited to the preamble of the claim, and that the body of the claim requires only "a fabric to be worn on the upper torso of the user, shoulder support means and a dorsal member." The district court construed the claim as proposed by Bass Pro, held that the "preamble" was not controlling of the claim scope, and that a full vest having a front and back is not required by the claim.

The grant of a contempt order for violation, by a modified device, of an injunction against infringement requires that the modified device infringes the patent, either literally or by application of the doctrine of equivalents. In KSM Fastening Systems, Inc. v. H.A. Jones Co., 776 F.2d 1522 (Fed. Cir. 1985) the court explained:

[A] judgment of contempt against an enjoined party for violation of an injunction against patent infringement by the making, using or selling of a modified device may not be upheld without a finding that the modified device falls within the admitted or adjudicated scope of the claims and is, therefore, an infringement.

Id. at 1530. As stated in Laitram Corp. v. Cambridge Wire Cloth Co., 863 F.2d 855, 867 (Fed. Cir. 1989), "[a]bsent infringement, there cannot be contempt for violating an injunction." However, in view of the settlement and Consent Judgment, the burden is on

the movant to establish infringement. The district court deemed that burden to have been met.

B

The district court held that claim 1 does not require a traditional vest as described in the specification, but requires only "said vest comprising a fabric to be worn on an upper torso of a user, said vest comprising at least a dorsal member and shoulder support means," unlimited by other components of a traditional vest. Bass Pro, slip op. at 8. Bass Pro states that the district court correctly recognized that use of a full vest is merely a preferred embodiment and that the scope of the claim encompasses garment structure other than a full vest.

Bass Pro argues that the term "vest" appears only in the "preamble" of claim 1, and that the preamble's phrase "said vest comprising" means that the vest component of the combination is met by the presence of fabric at the user's back, the "dorsal member" that is set forth in the body of the claim. The district court found: "It is clear from the patent that the presence of fabric or pockets on the side or front has nothing to do with the integrity of the seat element." Id.

Bass Pro stresses that the use of "comprising" in claim 1 means that the claim is satisfied by Cabela's device that contains only a dorsal member and shoulder supports, and that it is incorrect to read the claim as also requiring a vest, a term that appears in what Bass Pro designates as a preamble. Cabela's responds that "vest" is a substantive claim limitation, not merely a word of "preamble." Cabela's argues that the district court erred in ruling that the claim did not require a full vest, stressing that the invention described throughout the specification and claim is the combination of a vest and a folding seat, and

that the prosecution history reinforces that the invention is more than a "dorsal" panel of fabric on the wearer's back with shoulder support means. Cabela's cites the prosecution history, where the claims as originally filed did not mention a "vest." Claim 1 as filed was introduced as follows:

1 (filed). A garment having a seat member, said garment comprising of a fabric to be worn on an upper torso of a user, said garment comprising at least a dorsal member and shoulder support means, . . .

The examiner rejected the claims based on references where folding seats were carried by various forms of shoulder straps. For example, a patent to Varanakis showed a backpack frame capable of being converted into a chair, and the examiner stated that "the [Varanakis] assembly forms a garment for covering the user's back"; Bass Pro responded by replacing "a garment having a seat member" with "a combination vest and pivotable seat member," telling the examiner that the Varanakis device has "no vest or other type garment to which it attaches." Discussing another cited reference to Moody, the applicant emphasized the "unique combination of vest and pivotable seat":

[I]n the 40 years that have passed since the issuance of the patent to Moody, no devices similar to applicant's unique combination of vest and pivotable seat member for conversion into a back-supporting seat appear to have been developed, although many other advancements have occurred in the backpack and hunting equipment field.

Throughout the prosecution, the applicant relied on the vest to distinguish the combination from the devices in the references. Thus Bass Pro's argument that the vest "adds nothing" to the claim, and that the invention can include other garments worn on the upper body, is contrary to the prosecution history.

Claims are construed to implement the invention described in the specification and prosecution history, within the confines of the prior art. See Phillips v. AWH Corp., 415

F.3d 1303 (Fed. Cir. 2005) (*en banc*). It is clear that this patentee procured the patent based on the "unique combination of vest and pivotable seat member" stressed in the prosecution history, see Prosecution History of Serial No. 08/625,753, 1, 7-8 (Aug. 19, 1996), where the applicant placed these limitations in the claims. The district court erred in holding that the "vest" of claim 1 was not a material limitation to the claim.

On the correct claim construction the vest is a material element, and the claim cannot reasonably be found to be literally infringed. See Engel Industries, Inc. v. Lockformer Co., 96 F.3d 1398, 1405 (Fed. Cir. 1996) (literal infringement occurs when "every limitation recited in the claim is found in the accused device"). Absent literal infringement, the contempt order that was issued for violation of the injunction cannot stand and is vacated, along with the accompanying sanctions.

VACATED