

# United States Court of Appeals for the Federal Circuit

2006-1562

EGYPTIAN GODDESS, INC.,

Plaintiff-Appellant,

and

ADI TORKIYA,

Third Party Defendant,

v.

SWISA, INC. and DROR SWISA,

Defendants/Third Party Plaintiffs-  
Appellees.

Robert G. Oake, Jr., Oake Law Office, of Allen, Texas, argued for plaintiff-appellant.

Frederick Linton Medlin, Kirkpatrick & Lockhart Preston Gates Ellis LLP, of Dallas, Texas, argued for defendants/third party plaintiffs-appellees. With him on the brief was Linda G. Moore. Of counsel was Jeffrey L. Snow, of Boston, Massachusetts.

F. David LaRiviere, LaRiviere, Grubman & Payne LLP, of Monterey, California, for amicus curiae Monster Cable Products, Inc.

William Dunnegan, Dunnegan LLC, of New York, New York, for amicus curiae Industrial Designers Society of America. With him on the brief was Nikitas E. Nicolakis.

Edward D. Manzo, Cook, Alex, McFarron, Manzo, Cummings & Meher, Ltd., of Chicago, Illinois, for amici curiae Elite Group, Inc., et al.

Kevin T. Kramer, Pillsbury Winthrop Shaw Pittman LLP, of Washington, DC, for amicus curiae Federal Circuit Bar Association. With him on the brief were Edward R. Reines, Federal Circuit Bar Association, of Washington, DC, and Mark P. Walters, Darby & Darby, of Seattle, Washington.

George M. Sirilla, Pillsbury Winthrop Shaw Pittman LLP, of McLean, Virginia, for amicus curiae Daisy Manufacturing Company, Inc. With him on the brief was Stephanie F. Goeller, of Washington, DC.

Frank A. Angileri, Brooks Kushman P.C., of Southfield, Michigan, for amicus curiae Ford Global Technologies, LLC. With him on the brief was Marc Lorelli.

Christopher J. McGeehan, Greer, Burns & Crain, Ltd., of Chicago, Illinois, for amicus curiae Intellectual Property Law Association of Chicago.

Vandana Koelsch, Howrey LLP, of Washington, DC, for amicus curiae Bar Association of the District of Columbia.

Tracy-Gene G. Durkin, Sterne, Kessler, Goldstein & Fox P.L.L.C., of Washington, DC, for amicus curiae Intellectual Property Owners Association. With her on the brief was David K.S. Cornwell. Of counsel on the brief were Steven W. Miller, The Procter & Gamble Company, of Cincinnati, Ohio, and Richard F. Phillips, Exxon Mobil Corporation, of Houston, Texas. Of counsel was Herbert C. Wamsley, Intellectual Property Owners Association, of Washington, DC.

William T. Fryer, III, of Bethesda, Maryland, for amicus curiae Professor William T. Fryer, III.

Christopher J. Renk, Banner & Witcoff, Ltd., of Chicago, Illinois, for amici curiae Electrolux Home Products, Inc., et al. With him on the brief were Erik S. Maurer, of Chicago, Illinois, and Robert S. Katz, of Washington, DC. Of counsel was Christopher B. Roth.

Christopher V. Carani, McAndrews, Held & Malloy, Ltd., of Chicago, Illinois, for amicus curiae American Intellectual Property Law Association. With him on the brief was James Pooley, Morrison & Foerster LLP, of Palo Alto, California.

Perry J. Saidman, Saidman DesignLaw Group, of Silver Springs, Maryland, for amicus curiae Apple Inc.

Alan L. Barry, Bell, Boyd & Lloyd LLP, of Chicago, Illinois, for amici curiae LKQ Corporation, et al. With him on the brief were Heather A. Boice and Brian J. Arnold.

Valerie K. Friedrich, Baker & McKenzie LLP, of Houston, Texas, for amicus curiae Houston Intellectual Property Law Association.

Appealed from: United States District Court for the Northern District of Texas

Judge David C. Godbey

# United States Court of Appeals for the Federal Circuit

2006-1562

EGYPTIAN GODDESS, INC.,

Plaintiff-Appellant,

and

ADI TORKIYA,

Third Party Defendant,

v.

SWISA, INC. and DROR SWISA,

Defendants/Third Party Plaintiffs-  
Appellees.

Appeal from the United States District Court for the Northern District of Texas  
in case no. 3:03-CV-0594, Judge David C. Godbey.

---

DECIDED: September 22, 2008

---

Before MICHEL, Chief Judge, and NEWMAN, ARCHER, MAYER, LOURIE, RADER,  
SCHALL, BRYSON, GAJARSA, LINN, DYK, PROST, and MOORE, Circuit Judges.

BRYSON, Circuit Judge.

We granted rehearing en banc in this design patent case to address the appropriate legal standard to be used in assessing claims of design patent infringement.

Appellant Egyptian Goddess, Inc., (“EGI”) brought this action in the United States District Court for the Northern District of Texas, alleging that Swisa, Inc., and Dror Swisa (collectively, “Swisa”) had infringed EGI’s U.S. Design Patent No. 467,389 (“the ’389

patent”). The patent claimed a design for a nail buffer, consisting of a rectangular, hollow tube having a generally square cross-section and featuring buffer surfaces on three of its four sides. Swisa’s accused product consists of a rectangular, hollow tube having a square cross-section, but featuring buffer surfaces on all four of its sides.

The district court first issued an order construing the claim of the ’389 patent. In so doing, the district court sought to describe in words the design set forth in Figure 1 of the patent, which is depicted below:

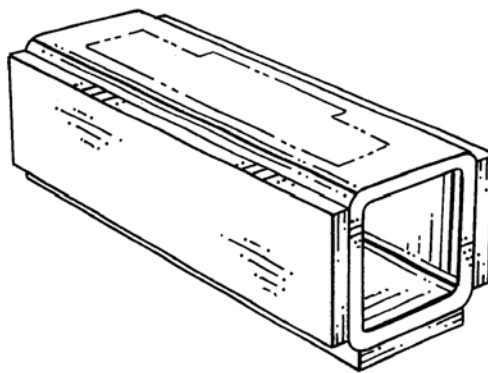

Upon study of the claimed design, the court described it as follows:

A hollow tubular frame of generally square cross section, where the square has sides of length  $S$ , the frame has a length of approximately  $3S$ , and the frame has a thickness of approximately  $T = 0.1S$ ; the corners of the cross section are rounded, with the outer corner of the cross section rounded on a 90 degree radius of approximately  $1.25T$ , and the inner corner of the cross section rounded on a 90 degree radius of approximately  $0.25T$ ; and with rectangular abrasive pads of thickness  $T$  affixed to three of the sides of the frame, covering the flat portion of the sides while leaving the curved radius uncovered, with the fourth side of the frame bare.

In the same order, the district court ruled that “Swisa has not shown that the appearance of the Buffer Patent is dictated by its utilitarian purpose.” The court therefore held that the patent is not invalid on the ground that the design was governed

solely by function. Egyptian Goddess, Inc. v. Swisa, Inc., Civil Action No. 3:03-CV-0594-N (N.D. Tex. Mar. 4, 2005), citing Seiko Epson Corp. v. Nu-Kote Int'l, Inc., 190 F.3d 1360, 1368 (Fed. Cir. 1999).

Swisa then moved for summary judgment of noninfringement. The district court granted the motion. Citing precedent of this court, the district court stated that the plaintiff in a design patent case must prove both (1) that the accused device is “substantially similar” to the claimed design under what is referred to as the “ordinary observer” test, and (2) that the accused device contains “substantially the same points of novelty that distinguished the patented design from the prior art.” Egyptian Goddess, Inc. v. Swisa, Inc., Civil Action No. 3:03-CV-0594-N (N.D. Tex. Dec. 14, 2005), citing Goodyear Tire & Rubber Co. v. Hercules Tire & Rubber Co., 162 F.3d 1113 (Fed. Cir. 1998). After comparing the claimed design and the accused product, the court held that Swisa’s allegedly infringing product did not incorporate the “point of novelty” of the ’389 patent, which the court identified as “a fourth, bare side to the buffer.”

The district court noted that the parties disagreed as to the points of novelty in the ’389 patent. EGI identified four elements in its design, and for each element it identified prior art that did not embody that element. EGI therefore contended that the point of novelty of the ’389 patent is the combination of those four elements. The district court, however, declined to address the question whether the point of novelty could be found in the combination of elements not present in various prior art references, because the court found that a single prior art reference, United States Design Patent No. 416,648 (“the Nailco patent”), contained all but one of the elements of the ’389 design. The court described the Nailco Patent as disclosing “a nail buffer with an open

and hollow body, raised rectangular pads, and open corners.” The only element of the ’389 patent design that was not present in the Nailco patent, according to the district court, was “the addition of the fourth side without a pad, thereby transforming the equilateral triangular cross-section into a square.” Because the Swisa product does not incorporate the point of novelty of the ’389 patent—a fourth side without a pad—the court concluded that there was no infringement.

EGL appealed, and a panel of this court affirmed. The panel agreed with the district court that there was no issue of material fact as to whether the accused Swisa buffer “appropriates the point of novelty of the claimed design.” Egyptian Goddess, Inc. v. Swisa, Inc., 498 F.3d 1354, 1355 (Fed. Cir. 2007). In reaching that conclusion, the panel stated that the point of novelty in a patented design “can be either a single novel design element or a combination of elements that are individually known in the prior art.” Id. at 1357. The panel added, however, that in order for a combination of individually known design elements to constitute a point of novelty, “the combination must be a non-trivial advance over the prior art.” Id.

The panel noted that EGL’s asserted point of novelty was a combination of four of the claimed design’s elements: (1) an open and hollow body, (2) a square cross-section, (3) raised rectangular buffer pads, and (4) exposed corners. The panel agreed with the district court’s observation that the Nailco prior art patent contained each of those elements except that the body was triangular, rather than square, in cross-section. 498 F.3d at 1358. In light of the prior art, the panel determined that “no reasonable juror could conclude that EGL’s asserted point of novelty constituted a non-trivial advance over the prior art.” Id.

The panel further observed that the various design elements of the claimed design “were each individually disclosed in the prior art.” 498 F.3d at 1358. The Swisa buffers, the panel noted, have raised, abrasive pads on all four sides, not just on three of the four sides, as in the claimed design, in which the fourth side is bare. The panel then concluded that “[w]hen considering the prior art in the nail buffer field, this difference between the accused design and the patented design cannot be considered minor.” Id. The panel therefore concluded that summary judgment was appropriate.

The dissenting judge would not have adopted the “non-trivial advance” test as a way of ascertaining whether a particular feature of the claimed design constituted a point of novelty for infringement purposes. In the view of the dissenting judge, the “non-trivial advance” test was inconsistent with and unsupported by prior precedent; it conflated the criteria for infringement and obviousness; it applied only to designs that involved combinations of design elements; and it improperly focused on the obviousness of each point of novelty, rather than the obviousness of the overall design. 498 F.3d at 1359-60 (Dyk, J., dissenting).

This court granted rehearing en banc and asked the parties to address several questions, including whether the “point of novelty” test should continue to be used as a test for infringement of a design patent; whether the court should adopt the “non-trivial advance test” as a means of determining whether a particular design feature qualifies as a point of novelty; how the point of novelty test should be administered, particularly when numerous features of the design differ from certain prior art designs; and whether district courts should perform formal claim construction in design patent cases.

The starting point for any discussion of the law of design patents is the Supreme Court's decision in Gorham Co. v. White, 81 U.S. 511 (1871). That case involved a design patent for the handles of tablespoons and forks. In its analysis of claim infringement, the Court stated that the test of identity of design “must be sameness of appearance, and mere difference of lines in the drawing or sketch . . . or slight variances in configuration . . . will not destroy the substantial identity.” Id. at 526-27. Identity of appearance, the Court explained, or “sameness of effect upon the eye, is the main test of substantial identity of design”; the two need not be the same “to the eye of an expert,” because if that were the test, “[t]here never could be piracy of a patented design, for human ingenuity has never yet produced a design, in all its details, exactly like another, so like, that an expert could not distinguish them.” Id. at 527.

The Gorham Court then set forth the test that has been cited in many subsequent cases: “[I]f, in the eye of an ordinary observer, giving such attention as a purchaser usually gives, two designs are substantially the same, if the resemblance is such as to deceive such an observer, inducing him to purchase one supposing it to be the other, the first one patented is infringed by the other.” 81 U.S. at 528. In the case before it, the Court concluded that “whatever differences there may be between the plaintiffs’ design and those of the defendant in details of ornament, they are still the same in general appearance and effect, so much alike that in the market and with purchasers they would pass for the same thing—so much alike that even persons in the trade would be in danger of being deceived.” Id. at 531.

Since the decision in Gorham, the test articulated by the Court in that case has been referred to as the “ordinary observer” test and has been recognized by lower



courts, including both of this court's predecessors, as the proper standard for determining design patent infringement. See, e.g., Blumcraft of Pittsburgh v. United States, 372 F.2d 1014, 1016 (Ct. Cl. 1967); In re Dubois, 262 F.2d 88, 91 (CCPA 1958). However, in a series of cases tracing their origins to Litton Systems, Inc. v. Whirlpool Corp., 728 F.2d 1423 (Fed. Cir. 1984), this court has held that proof of similarity under the ordinary observer test is not enough to establish design patent infringement. Rather, the court has stated that the accused design must also appropriate the novelty of the claimed design in order to be deemed infringing. The court in Litton Systems wrote as follows:

For a design patent to be infringed . . . no matter how similar two items look, "the accused device must appropriate the novelty in the patented device which distinguishes it from the prior art." That is, even though the court compares two items through the eyes of the ordinary observer, it must nevertheless, to find infringement, attribute their similarity to the novelty which distinguishes the patented device from the prior art.

Litton Systems, 728 F.2d at 1444 (citations omitted). After identifying the combination of features in the design that it considered novel, the court in Litton Systems held that the accused design had none of those features and therefore did not infringe. Id.

In a number of cases decided after Litton Systems, this court has interpreted the language quoted above to require that the test for design patent infringement consider both the perspective of the ordinary observer and the particular novelty in the claimed design. See, e.g., Bernhardt, L.L.C. v. Collezione Europa USA, Inc., 386 F.3d 1371, 1383 (Fed. Cir. 2004); Contessa Food Prods., Inc. v. Conagra, Inc., 282 F.3d 1370, 1377 (Fed. Cir. 2002); Unidynamics Corp. v. Automatic Prods. Int'l, Inc., 157 F.3d 1311, 1323-24 (Fed. Cir. 1998); Oakley, Inc. v. Int'l Tropic-Cal., Inc., 923 F.2d 167, 169 (Fed.

Cir. 1991); Avia Group Int'l, Inc. v. L.A. Gear Cal., Inc., 853 F.2d 1557, 1565 (Fed. Cir. 1988).

The extent to which the point of novelty test has been a separate test has not always been clear in this court's case law. In cases decided shortly after Litton, the court described the ordinary observer test and the point of novelty test as "conjunctive." See L.A. Gear, Inc. v. Thom McAn Shoe Co., 988 F.2d 1117, 1125 (Fed. Cir. 1993); Shelcore, Inc. v. Durham Indus., Inc., 745 F.2d 621, 628 n.16 (Fed. Cir. 1984). It has not been until much more recently that this court has described the ordinary observer and point of novelty tests as "two distinct tests" and has stated that "[t]he merger of the point of novelty test and the ordinary observer test is legal error." Unidynamics Corp., 157 F.3d at 1323-24; see also Lawman Armor Corp. v. Winner Int'l, LLC, 437 F.3d 1383, 1384 (Fed. Cir. 2006); Contessa Food Prods., Inc., 282 F.3d at 1377; Sun Hill Indus., Inc. v. Easter Unlimited, Inc., 48 F.3d 1193, 1197 (Fed. Cir. 1995).

Regardless of the differences in the way it has been characterized, the point of novelty test has proved reasonably easy to apply in simple cases in which the claimed design is based on a single prior art reference and departs from that reference in a single respect. In such cases, it is a simple matter to identify the point of novelty and to determine whether the accused design has appropriated the point of novelty, as opposed to copying those aspects of the claimed design that were already in the prior art. However, the point of novelty test has proved more difficult to apply where the claimed design has numerous features that can be considered points of novelty, or where multiple prior art references are in issue and the claimed design consists of a combination of features, each of which could be found in one or more of the prior art

designs. In particular, applying the point of novelty test where multiple features and multiple prior art references are in play has led to disagreement over whether combinations of features, or the overall appearance of a design, can constitute the point of novelty of the claimed design. Compare Lawman Armor Corp. v. Winner Int'l, LLC, 449 F.3d 1190 (Fed. Cir. 2006) (supplemental opinion on petition for rehearing), with Lawman Armor Corp. v. Winner Int'l, LLC, 449 F.3d 1192 (Fed. Cir. 2006) (Newman, J., dissenting from denial of rehearing en banc). In light of the questions surrounding the status and application of the point of novelty test, we use this case as a vehicle for reconsidering the place of the point of novelty test in design patent law generally.

## II

EGL argues that this court should no longer recognize the point of novelty test as a second part of the test for design patent infringement, distinct from the ordinary observer test established in Gorham. Instead of requiring the fact-finder to identify one or more points of novelty in the patented design and then determining whether the accused design has appropriated some or all of those points of novelty, EGL contends that the ordinary observer test can fulfill the purposes for which the point of novelty test was designed, but with less risk of confusion. As long as the ordinary observer test focuses on the “appearance that distinguishes the patented design from the prior art,” EGL contends that it will enable the fact-finder to address the proper inquiry, i.e., whether an ordinary observer, familiar with the prior art, would be deceived into thinking that the accused design was the same as the patented design. Relatedly, EGL argues that if the ordinary observer test is performed from the perspective of an ordinary observer who is familiar with the prior art, there is no need for a separate “non-trivial

advance” test, because the attention of an ordinary observer familiar with prior art designs will naturally be drawn to the features of the claimed and accused designs that render them distinct from the prior art.

Several of the amici make essentially the same point, referring to the proper approach as calling for a three-way visual comparison between the patented design, the accused design, and the closest prior art. The amici point out that courts, including this one, have on occasion applied that approach in design patent cases, without identifying it as a separate test. See, e.g., Brief of Amicus Curiae Apple, Inc., at 19 (citing, inter alia, Elmer v. ICC Fabricating, Inc., 67 F.3d 1571 (Fed. Cir., 1995); Braun, Inc. v. Dynamics Corp. of Am., 975 F.2d 815 (Fed Cir. 1992); and Bergstrom v. Sears, Roebuck & Co., 496 F. Supp. 476 (D. Minn. 1980)).

Swisa counters that this court may not, and should not, abandon the point of novelty test. According to Swisa, the point of novelty test was adopted by the Supreme Court in Smith v. Whitman Saddle Co., 148 U.S. 674 (1893). Swisa interprets that case as dictating the use of the point of novelty test as a second and distinct test for design patent infringement, separate from the ordinary observer test set forth in Gorham. Swisa contends that the subsequent decisions of this court and others applying the point of novelty test are soundly based on Whitman Saddle, and that we cannot depart from that test without disregarding that governing Supreme Court precedent as well as intervening precedent from other courts of appeals.

We disagree with Swisa’s submission. A close reading of Whitman Saddle and subsequent authorities indicates that the Supreme Court did not adopt a separate point of novelty test for design patent infringement cases. In fact, a study of the development

of design patent law in the years after Gorham shows that the point of novelty test, in its current form, is of quite recent vintage. After a review of those authorities, which we examine in some detail below, we conclude that the point of novelty test, as a second and free-standing requirement for proof of design patent infringement, is inconsistent with the ordinary observer test laid down in Gorham, is not mandated by Whitman Saddle or precedent from other courts, and is not needed to protect against unduly broad assertions of design patent rights.

Whitman Saddle involved a patent on a design for a saddle. The Court began by reciting the requirements for obtaining patent protection for a design. The Court emphasized the importance of “invention” to the patentability of a design. It stated, “Mere mechanical skill is insufficient. There must be something akin to genius, an effort of the brain as well as the hand. The adaptation of old devices or forms to new purposes, however convenient, useful, or beautiful they may be in their new role, is not invention.” 148 U.S. at 679. The Court then explained (id.):

The exercise of the inventive or originative faculty is required, and a person cannot be permitted to select an existing form, and simply put it to a new use, any more than he can be permitted to take a patent for the mere double use of a machine. If, however, the selection and adaptation of an existing form is more than the exercise of the imitative faculty, and the result is in effect a new creation, the design may be patentable.

In the case before it, the Court characterized the patented saddle design as a combination of elements from two saddle designs that were well known in the art. The Court explained that the patented design consisted of a combination of the front half of the so-called Granger saddle and the back end of the so-called Jenifer saddle. The design differed from a simple combination of the two known saddles, according to the

Court, only in that the front end of the design had “a nearly perpendicular drop of some inches at the rear of the pommel,” unlike in the Granger saddle. Id. at 680.

Although the trial court, sitting in equity, concluded that the design was patentable, the Supreme Court disagreed. The Court wrote, “Nothing more was done in this instance (except as hereafter noted) than to put the two halves of these saddles together in the exercise of the ordinary skill of workmen of the trade, and in the way and manner ordinarily done.” 148 U.S. at 681. The Court noted that there was a difference between the pommel of the designed saddle and the pommel of the Granger saddle, and it added that the “shape of the front end being old, the sharp drop of the pommel at the rear seems to constitute what was new and to be material.” Id. at 682. That feature, however, was not present in the defendants’ saddle. The Court then concluded with the following remarks (id.):

If, therefore, this drop were material to the design, and rendered it patentable as a complete and integral whole, there was no infringement. As before said, the design of the patent had two features of difference as compared with the Granger saddle, one the cantle, the other the drop; and unless there was infringement as to the latter there was none at all, since the saddle design of the patent does not otherwise differ from the old saddle with the old cantle added, an addition frequently made. Moreover, that difference was so marked that in our judgment the defendant’s saddle could not be mistaken for the saddle of the complainant.

Because Whitman Saddle was an action in equity, the Court did not distinguish sharply between its analysis of patentability and its discussion of infringement. Within the same passage, the Court moved from stating that it could not agree with the trial court that the design in issue was patentable to the conclusion that if the design were patentable because of the drop at the rear of the pommel, there was no infringement. Nothing in the Court’s opinion suggested that it was fashioning a separate point of

novelty test for infringement. The point the Court was making was that, viewed in light of the similarities between the prior art and the patented design, the accused design did not contain the single feature that would have made it appear distinctively similar to the patented design rather than like the numerous prior art designs. For that reason, the Court held, the accused design did not infringe.

Subsequent cases applied that principle, interpreting the ordinary observer test of Gorham to require that the perspective of the ordinary observer be informed by a comparison of the patented design and the accused design in light of the prior art, so as to enable the fact-finder to determine whether the accused design had appropriated the inventiveness of the patented design. For example, two cases decided in the wake of Whitman Saddle shed light on the Supreme Court's analysis in Whitman Saddle and illustrate the application of the ordinary observer test in light of the prior art.

In the first of those cases, Bevin Brothers Manufacturing Co. v. Starr Brothers Bell Co., 114 F. 362 (C.C.D. Conn. 1902), the patent drawing showed an oblate spheroid and neck, and the claim covered "a bell as herein shown and described." Sitting in equity, the court addressed both validity and infringement, noting that the test of identity on both issues "is the eye of the ordinary observer." Id. at 363. After noting that the patented form was commonly found in a variety of prior art structures, the court held that the "defense of want of patentable novelty is sustained." Id. As for infringement, the court again consulted particular objects in the prior art having a similar shape, including a door knob, and concluded that "[t]he shape of the defendant's bell differs from plaintiff's more widely than plaintiff's differs from the door knob, and therefore defendants' construction does not infringe the patent." Id. Thus, the court's

approach, like that of the Supreme Court in Whitman Saddle, did not employ a point of novelty test, but invoked the ordinary observer test in which the observer was comparing the patented and accused designs in the context of similar designs found in the prior art.

The second case, Zidell v. Dexter, 262 F. 145 (9th Cir. 1920), cited Whitman Saddle for the proposition that under the ordinary observer standard, a patented design that consists “only of bringing together old elements with slight modifications of form” is not infringed by “another who uses the same elements with his own variations of form . . . if his design is distinguishable by the ordinary observer from the patented design.” Id. at 146. The court emphasized the importance of similar prior art designs to the determination of infringement under the ordinary observer test:

The evidence shows that at and prior to the conception of this design there were in use and on sale very many similar garments, with variations in design so slight as to leave to the ordinary observer the impression of a very general resemblance, and we must assume that to womankind, who are the purchasers in the main of this class of garment, these various coincident forms of garments were known, and whether such purchasers would be deceived into taking the garments which are alleged to infringe for a garment of the patented design would necessarily depend largely upon that general knowledge.

Id. at 147.

Some years later, the Sixth Circuit addressed a similar issue in a case involving a design patent on a combination ash tray and electric lighter. Applied Arts Corp. v. Grand Rapids Metalcraft Corp., 67 F.2d 428 (6th Cir. 1933). The district court found infringement by two of the defendant’s designs upon finding that the resemblance between the patented design and the accused design was such as to deceive the ordinary observer. In analyzing the case, the court addressed the question whether the



ordinary observer test of Gorham was in conflict with the principle that “similitude of appearance is to be judged by the scope of the patent in relation to the prior art.” Id. at 429.

The court explained that the ordinary observer of the Gorham test was not one “who has never seen an ash tray or a cigar lighter, but one who, though not an expert, has reasonable familiarity with such objects,” and is capable of assessing the similarity of the patented and accused designs in light of the similar objects in the prior art. 67 F.2d at 430. Viewing the ordinary observer test in that manner, the court stated:

[W]hile there is some similarity between the patented and alleged infringing designs, which without consideration of the prior art might seem important, yet such similarity as is due to common external configuration is no greater, if as great, between the patented and challenged designs as between the former and the designs of the prior art.

Id. After noting the similarities between the patented design and the prior art designs, the court concluded that the differences between the two “are no greater than those that exist between the patented design and the alleged infringing designs.” Accordingly, the court concluded, assuming the patent to be valid “it is quite clear it is entitled to a very limited interpretation and that so limited the defendant’s designs do not infringe.” Id. The court ruled that while it was aware that similarity “is not to be determined by making too close an analysis of detail,” nonetheless, “where in a crowded art the composite of differences presents a different impression to the eye of the average observer (as above defined), infringement will not be found.” Id.

That precedent was followed by the Eighth Circuit in Sears, Roebuck & Co. v. Talge, 140 F.2d 395 (8th Cir. 1944). The district court in that case held that the defendant’s home fruit juicer infringed the plaintiff’s patents on fruit juicer designs. The

court stated that the test for design patent infringement involves two elements: (1) “the identity of appearance, or sameness of effect as a whole upon the eye of an ordinary purchaser must be such as to deceive him, inducing him to purchase one, supposing it to be the other” and (2) “the accused device must appropriate the novelty in the patented device which distinguishes it from the prior art.” Id. at 395-96. To make the latter determination, the court explained, “requires a comparison of the features of the patented designs with the prior art and with the accused design.” Id. at 396. By examining the prior art fruit juicers, the court was able to identify the “novel elements embodied in the [patented] design.” The court then determined that there was no identity of appearance with respect to those elements between the claimed designs and the accused products. Id.

The Sears, Roebuck and Applied Arts cases, in turn, became the principal precedents relied upon by this court in the seminal Litton Systems case to which this court’s precedents dealing with the point of novelty test trace their origin. In Litton Systems, as in Sears, Roebuck, the court identified the Gorham ordinary observer test as the starting point for design patent infringement. Quoting from Sears, Roebuck, the Litton court added, however, that “no matter how similar two items look, ‘the accused device must appropriate the novelty in the patented device which distinguishes it from the prior art.’” 728 F.2d at 1444. That is, the court added, after comparing two items through the eyes of the ordinary observer, the court must, to find infringement, “attribute their similarity to the novelty which distinguishes the patented device from the prior art.” Id. The court then referred to that second test as the point of novelty approach, and that

tag has been applied to the second part of the design patent infringement test ever since.

In analyzing the claim of infringement, the court in Litton Systems focused on what it characterized as the novelty of the patent in suit, i.e., “the combination on a microwave oven’s exterior of a three-stripe door frame, a door without a handle, and a latch release lever on the control panel.” Significantly, however, the court quoted from the Applied Arts case and stated that the degree of similarity between the accused design and the patented design had to be assessed in light of the designs in the prior art. The court noted that where, as in the case before it, “a field is crowded with many references relating to the design of the same type of appliance, we must construe the range of equivalents very narrowly.” 728 F.2d at 1444. Accordingly, the court held that the scope of protection of the patent in that case was limited to “a narrow range” that did not include the accused design. Id.

As noted, this court has cited Litton Systems for the proposition that the point of novelty test is separate from the ordinary observer test and requires the patentee to point out the point of novelty in the claimed design that has been appropriated by the accused design. We think, however, that Litton and the predecessor cases on which it relied are more properly read as applying a version of the ordinary observer test in which the ordinary observer is deemed to view the differences between the patented design and the accused product in the context of the prior art. When the differences between the claimed and accused design are viewed in light of the prior art, the attention of the hypothetical ordinary observer will be drawn to those aspects of the claimed design that differ from the prior art. And when the claimed design is close to

the prior art designs, small differences between the accused design and the claimed design are likely to be important to the eye of the hypothetical ordinary observer. It was for that reason that the Supreme Court in Whitman Saddle focused on the one feature of the patented saddle design that departed from the prior art—the sharp drop at the rear of the pommel. To an observer familiar with the multitude of prior art saddle designs, including the design incorporating the Granger pommel and the Jenifer cantle, “an addition frequently made,” 148 U.S. at 682, the sharp drop at the rear of the pommel would be important to the overall appearance of the design and would serve to distinguish the accused design, which did not possess that feature, from the claimed design.

The same can be said of the courts’ analysis in Bevin Brothers, Zidell, Applied Arts, and Sears, Roebuck. In Bevin Brothers and Zidell, the courts emphasized that the defendant’s product would appear different from the plaintiff’s protected design to an ordinary observer aware of the great number of closely similar prior art designs. In Applied Arts, the accused ash tray would not appear to be the same as the claimed ash tray as long as “similitude of appearance is . . . judged by the scope of the patent in relation to the prior art.” 67 F.2d at 429. And in Sears, Roebuck, the court concluded that the accused fruit juicer would not appear similar to the claimed design if the factfinder performed the required “comparison of the features of the patented designs with the prior art and with the accused design.” 140 F.2d at 396.

Not only is this approach consistent with the precedents discussed above, but it makes sense as a matter of logic as well. Particularly in close cases, it can be difficult to answer the question whether one thing is like another without being given a frame of

reference. The context in which the claimed and accused designs are compared, i.e., the background prior art, provides such a frame of reference and is therefore often useful in the process of comparison. Where the frame of reference consists of numerous similar prior art designs, those designs can highlight the distinctions between the claimed design and the accused design as viewed by the ordinary observer.

Applying the ordinary observer test with reference to prior art designs also avoids some of the problems created by the separate point of novelty test. One such problem is that the point of novelty test has proved difficult to apply in cases in which there are several different features that can be argued to be points of novelty in the claimed design. In such cases, the outcome of the case can turn on which of the several candidate points of novelty the court or fact-finder focuses on. The attention of the court may therefore be focused on whether the accused design has appropriated a single specified feature of the claimed design, rather than on the proper inquiry, i.e., whether the accused design has appropriated the claimed design as a whole. See Amini Innovation Corp. v. Anthony Cal., Inc., 439 F.3d 1365, 1370-71 (Fed. Cir. 2006); Keystone Retaining Wall Sys., Inc. v. Westrock, Inc., 997 F.2d 1444, 1450 (Fed. Cir. 1993); Braun Inc., 975 F.2d at 820.

In addition, the more novel the design, and the more points of novelty that are identified, the more opportunities there are for a defendant to argue that its design does not infringe because it does not copy all of the points of novelty, even though it may copy most of them and even though it may give the overall appearance of being identical to the claimed design. In such cases, a test that asks how an ordinary observer with knowledge of the prior art designs would view the differences between the

claimed and accused designs is likely to produce results more in line with the purposes of design patent protection.

This court has characterized the purpose of the point of novelty test as being “to focus on those aspects of a design which render the design different from prior art designs.” Sun Hill Indus., Inc., 48 F.3d at 1197, quoting Winner Int’l Corp. v. Wolo Mfg. Corp., 905 F.2d 375, 376 (Fed. Cir. 1990). That purpose can be equally well served, however, by applying the ordinary observer test through the eyes of an observer familiar with the prior art. If the accused design has copied a particular feature of the claimed design that departs conspicuously from the prior art, the accused design is naturally more likely to be regarded as deceptively similar to the claimed design, and thus infringing. At the same time, unlike the point of novelty test, the ordinary observer test does not present the risk of assigning exaggerated importance to small differences between the claimed and accused designs relating to an insignificant feature simply because that feature can be characterized as a point of novelty.

This approach also has the advantage of avoiding the debate over the extent to which a combination of old design features can serve as a point of novelty under the point of novelty test. An ordinary observer, comparing the claimed and accused designs in light of the prior art, will attach importance to differences between the claimed design and the prior art depending on the overall effect of those differences on the design. If the claimed design consists of a combination of old features that creates an appearance deceptively similar to the accused design, even to an observer familiar with similar prior art designs, a finding of infringement would be justified. Otherwise, infringement would not be found.

One function that has been served by the point of novelty test, according to *Swisa* and its supporting amici, is to cabin unduly broad assertions of design patent scope by ensuring that a design that merely embodies or is substantially similar to prior art designs is not found to infringe. Again, however, we believe that the preferable way to achieve that purpose is to do so directly, by relying on the ordinary observer test, conducted in light of the prior art. Our rejection of the point of novelty test does not mean, of course, that the differences between the claimed design and prior art designs are irrelevant. To the contrary, examining the novel features of the claimed design can be an important component of the comparison of the claimed design with the accused design and the prior art. But the comparison of the designs, including the examination of any novel features, must be conducted as part of the ordinary observer test, not as part of a separate test focusing on particular points of novelty that are designated only in the course of litigation.

On the basis of the foregoing analysis, we hold that the “point of novelty” test should no longer be used in the analysis of a claim of design patent infringement. Because we reject the “point of novelty” test, we also do not adopt the “non-trivial advance” test, which is a refinement of the “point of novelty” test. Instead, in accordance with *Gorham* and subsequent decisions, we hold that the “ordinary observer” test should be the sole test for determining whether a design patent has been infringed. Under that test, as this court has sometimes described it, infringement will not be found unless the accused article “embod[ies] the patented design or any colorable imitation thereof.” *Goodyear Tire & Rubber Co.*, 162 F.3d at 1116-17; see also

Arminiak & Assocs., Inc. v. Saint-Gobain Calmar, Inc., 501 F.3d 1314, 1319 (Fed. Cir. 2007).

In some instances, the claimed design and the accused design will be sufficiently distinct that it will be clear without more that the patentee has not met its burden of proving the two designs would appear “substantially the same” to the ordinary observer, as required by Gorham. In other instances, when the claimed and accused designs are not plainly dissimilar, resolution of the question whether the ordinary observer would consider the two designs to be substantially the same will benefit from a comparison of the claimed and accused designs with the prior art, as in many of the cases discussed above and in the case at bar. Where there are many examples of similar prior art designs, as in a case such as Whitman Saddle, differences between the claimed and accused designs that might not be noticeable in the abstract can become significant to the hypothetical ordinary observer who is conversant with the prior art.

We emphasize that although the approach we adopt will frequently involve comparisons between the claimed design and the prior art, it is not a test for determining validity, but is designed solely as a test of infringement. Thus, as is always the case, the burden of proof as to infringement remains on the patentee. However, if the accused infringer elects to rely on the comparison prior art as part of its defense against the claim of infringement, the burden of production of that prior art is on the accused infringer. To be sure, we have stated that the burden to introduce prior art under the point of novelty test falls on the patentee. See Bernhardt, 386 F.3d at 1384. Under the ordinary observer test, however, it makes sense to impose the burden of production as to any comparison prior art on the accused infringer. The accused



infringer is the party with the motivation to point out close prior art, and in particular to call to the court's attention the prior art that an ordinary observer is most likely to regard as highlighting the differences between the claimed and accused design. Regardless of whether the accused infringer elects to present prior art that it considers pertinent to the comparison between the claimed and accused design, however, the patentee bears the ultimate burden of proof to demonstrate infringement by a preponderance of the evidence. As in our recent decision in In re Seagate Technology, LLC, we "leave it to future cases to further develop the application of this standard." 497 F.3d 1360, 1371 (Fed. Cir. 2007) (en banc).

### III

One of the issues raised by this court in its order granting en banc review was whether trial courts should conduct claim construction in design patent cases. While this court has held that trial courts have a duty to conduct claim construction in design patent cases, as in utility patent cases, see Elmer, 67 F.3d at 1577, the court has not prescribed any particular form that the claim construction must take. To the contrary, the court has recognized that design patents "typically are claimed as shown in drawings," and that claim construction "is adapted accordingly." Arminiak & Assocs., Inc., 501 F.3d at 1319; see also Goodyear Tire & Rubber Co., 162 F.3d at 1116. For that reason, this court has not required that the trial court attempt to provide a detailed verbal description of the claimed design, as is typically done in the case of utility patents. See Contessa Food Prods., Inc., 282 F.3d at 1377 (approving district court's

construction of the asserted claim as meaning “a tray of a certain design as shown in Figures 1-3”).<sup>1</sup>

As the Supreme Court has recognized, a design is better represented by an illustration “than it could be by any description and a description would probably not be intelligible without the illustration.” Dobson v. Dornan, 118 U.S. 10, 14 (1886). The Patent and Trademark Office has made the same observation. Manual of Patent Examining Procedure § 1503.01 (8th ed. 2006) (“[A]s a rule the illustration in the drawing views is its own best description.”). Given the recognized difficulties entailed in trying to describe a design in words, the preferable course ordinarily will be for a district court not to attempt to “construe” a design patent claim by providing a detailed verbal description of the claimed design.

With that said, it is important to emphasize that a district court’s decision regarding the level of detail to be used in describing the claimed design is a matter within the court’s discretion, and absent a showing of prejudice, the court’s decision to issue a relatively detailed claim construction will not be reversible error. At the same time, it should be clear that the court is not obligated to issue a detailed verbal description of the design if it does not regard verbal elaboration as necessary or helpful. In addition, in deciding whether to attempt a verbal description of the claimed design,

---

<sup>1</sup> This court has required that in determining obviousness, a district court must attempt to “translate [the] visual descriptions into words” in order to communicate the reasoning behind the court’s decision and to enable “the parties and appellate courts . . . to discern the internal reasoning employed by the trial court.” Durling v. Spectrum Furniture Co., 101 F.3d 100, 102 (Fed. Cir. 1996). Requiring such an explanation of a legal ruling as to invalidity is quite different from requiring an elaborate verbal claim construction to guide the finder of fact in conducting the infringement inquiry.

the court should recognize the risks entailed in such a description, such as the risk of placing undue emphasis on particular features of the design and the risk that a finder of fact will focus on each individual described feature in the verbal description rather than on the design as a whole. In this case, for example, the district court came up with a detailed verbal description of the claimed design. We see no inaccuracy in the court's description, and neither party has pointed to any prejudice resulting from the court's interpretation. Yet it is not clear that the considerable effort needed to fashion the verbal description contributed enough to the process of analyzing the case to justify the effort.

While it may be unwise to attempt a full description of the claimed design, a court may find it helpful to point out, either for a jury or in the case of a bench trial by way of describing the court's own analysis, various features of the claimed design as they relate to the accused design and the prior art. In a case such as this one, for example, there would be nothing wrong with the court pointing out to a jury that in the patented design only three sides have buffers attached, while in the accused product (and in the three-sided Nailco patent), all of the sides have buffers attached. It would similarly be permissible for the court to point out that, for example, although the Falley Buffer Block has four sides, it is not hollow, unlike the design of the '389 patent, the Nailco patent, and the accused Swisa product.

Apart from attempting to provide a verbal description of the design, a trial court can usefully guide the finder of fact by addressing a number of other issues that bear on the scope of the claim. Those include such matters as describing the role of particular conventions in design patent drafting, such as the role of broken lines, see 37 C.F.R. §

1.152; assessing and describing the effect of any representations that may have been made in the course of the prosecution history, see Goodyear Tire & Rubber Co., 162 F.3d at 1116; and distinguishing between those features of the claimed design that are ornamental and those that are purely functional, see Oddzon Prods., Inc. v. Just Toys, Inc., 122 F.3d 1396, 1405 (Fed. Cir. 1997) (“Where a design contains both functional and non-functional elements, the scope of the claim must be construed in order to identify the non-functional aspects of the design as shown in the patent.”).

Providing an appropriate measure of guidance to a jury without crossing the line and unduly invading the jury’s fact-finding process is a task that trial courts are very much accustomed to, and any attempt by an appellate court to guide that process in detail is likely to do more harm than good. We therefore leave the question of verbal characterization of the claimed designs to the discretion of trial judges, with the proviso that as a general matter, those courts should not treat the process of claim construction as requiring a detailed verbal description of the claimed design, as would typically be true in the case of utility patents.

#### IV

We now turn to the facts of this case. It is agreed that the general shape of the accused nail buffer at issue in this case is the same as that of the patented buffer design. The difference between the two is that the accused buffer has raised buffing pads on all four sides, while the patented buffer has buffing pads on only three sides. The two closest prior art nail buffers before the court were the Falley nail buffer, which has a solid, rectangular cross section with slightly raised buffers on all sides, and the Nailco patent, which shows a nail buffer design having a triangular shape and a hollow

cross section, and in which raised buffing pads are located on all three sides. The four nail buffers are pictured below:

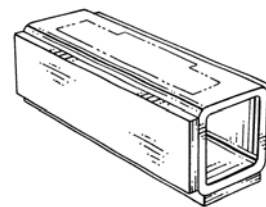
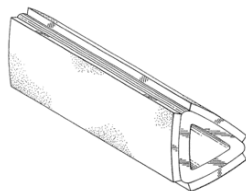

Falley Buffer Block

Nailco Patent

Swisa Buffer

'389 patent

The question before this court under the standard we have set forth above is whether an ordinary observer, familiar with the prior art Falley and Nailco designs, would be deceived into believing the Swisa buffer is the same as the patented buffer. EGI argues that such an observer would notice a difference between the prior art and the '389 patent, consisting of “the hollow tube that is square in cross section and that has raised pads with exposed gaps at the corners.” To support that contention, EGI invokes the declaration of its expert witness, Kathleen Eaton. After viewing the patented, accused, and Nailco buffers, Ms. Eaton concluded that the patented and accused designs would “confuse an ordinary observer into purchasing the accused buffer thinking it to be the patented buffer design.” She reached that conclusion, she explained, because “the substantially similar appearance [between the accused and patented designs] results from both designs having a hollow tube, square in cross section and rectangular in length, with multiple raised rectangular pads mounted on the sides, and that do not cover the corners of the tube.” While recognizing that the accused buffer has pads on all four sides and that the claimed design has buffer pads on only three sides, she stated that “I do not believe that, to an ordinary observer and purchaser of nail buffers, the presence of one more buffer pad[s] greatly alters the

ornamental effect and appearance of the whole design as compared to the whole patented design.”

Swisa counters that the '389 patent closely tracks the design of the Nailco nail buffer, except that it “add[s] a fourth side without an abrasive pad, resulting in square ends.” In light of the close prior art buffers, including a number having square cross-sections, Swisa argues that an ordinary observer would notice the difference between the claimed and accused designs. To support that contention, Swisa cites the declaration of its expert, Steve Falley. Mr. Falley addressed the differences among the prior art designs, the accused design, and patented design, and he concluded that

you could simply add to the Nailco Buffer a fourth side without an abrasive on it. This merely takes the Nailco Buffer to the block shape of the original Falley Buffer Block, while keeping the hollow aspect of the Nailco Buffer. As there had already been on the market for a long time 3-way buffer blocks that had no abrasive on one side, it was also obvious after the Nailco Buffer that you could have a three way hollow buffer that had four sides but with no abrasive on one side.

Mr. Falley added that “four-way” nail buffers having four different abrasive surfaces have been made since 1985, and that four-sided “buffer blocks” have been on the market since 1987. He pointed to catalogs showing three-sided and four-sided buffer blocks that have been offered for sale since at least 1994, and in light of his knowledge of the industry, he stated that the “number of sides with abrasive surface on them would be important to purchasers because it determines whether a buffer is a “three way buffer” or a “four way buffer.” Accordingly, he concluded:

The difference between a buffer with abrasive on three sides—a “three-way buffer”—and a buffer with abrasive on four sides—a “four-way buffer”—is immediately apparent to any consumer used to buying nail buffers. Even if such a consumer did not have a preference for either three-way or four-way buffers (although they almost always do), they would at a glance be able to tell that a buffer with abrasive on only three

sides had abrasive on three sides, and was a three-way buffer, while a buffer with abrasive on four sides had abrasive on all four sides, and was a four-way buffer. I cannot imagine consumers would buy buffers with abrasive on four sides thinking that they were buying buffers with abrasive on three sides.

The problem with Ms. Eaton's declaration is that she characterized the accused and patented designs as similar because they both have square cross sections and "multiple" raised buffer pads, without directly acknowledging that the patented design has three pads while the accused design has four, one on each side. She also failed to address the fact that the design of the Nailco patent is identical to the accused device except that the Nailco design has three sides rather than four. Thus, she could as easily have said that the Nailco buffer design "is like the accused design because both designs have a hollow tube, have multiple rectangular sides with raised rectangular pads mounted on each side that do not cover the corners of the tube," in which case the Nailco prior art buffer would be seen to closely resemble the accused design. Nothing about Ms. Eaton's declaration explains why an ordinary observer would regard the accused design as being closer to the claimed design than to the Nailco prior art patent. In fact, Ms. Eaton's reference to the prior art buffers is limited to the single, and conclusory, comment that an ordinary observer and purchaser of nail buffers would consider the patented design and the accused buffer to be substantially similar, "particularly in light of other nail buffers, such as a solid block buffer and the hollow triangular Nailco buffer."

In light of the similarity of the prior art buffers to the accused buffer, we conclude that no reasonable fact-finder could find that EGI met its burden of showing, by a preponderance of the evidence, that an ordinary observer, taking into account the prior

art, would believe the accused design to be the same as the patented design. In concluding that a reasonable fact-finder could not find infringement in this case, we reach the same conclusion that the district court reached, and for many of the same reasons. Although we do so by using the ordinary observer test as informed by the prior art, rather than by applying the point of novelty test, our analysis largely tracks that of the district court. After analyzing the Nailco patent and the claimed design, as they related to the accused design, the district court concluded that “in the context of nail buffers, a fourth side without a pad is not substantially the same as a fourth side with a pad.” While the district court focused on the differences in the particular feature at issue rather than the effect of those differences on the appearance of the design as a whole, we are satisfied that the difference on which the district court focused is important, viewed in the context of the prior art.

Finally, although we do not adopt the “non-trivial advance” test employed by the panel in this case, we note that our analysis under the ordinary observer test is parallel to the panel’s approach in an essential respect. The panel focused on viewing the difference between the claimed and accused designs in light of the prior art, as we do. The panel wrote: “The Swisa buffers have raised, abrasive pads on all four sides. When considering the prior art in the nail buffer field, this difference between the accused design and the patented design cannot be considered minor.” 498 F.3d at 1358. That point captures the essence of the rationale of our decision today, even though the panel decision employed a different analytical approach. For the foregoing reasons, we sustain the district court’s entry of summary judgment of no infringement, but we do so under the ordinary observer test in the form that we have adopted, and



without using the point of novelty test that we have disapproved. In the language used by the Supreme Court in Gorham, 81 U.S. at 528, we hold that the accused design could not reasonably be viewed as so similar to the claimed design that a purchaser familiar with the prior art would be deceived by the similarity between the claimed and accused designs, “inducing him to purchase one supposing it to be the other.”

AFFIRMED.