

United States Court of Appeals for the Federal Circuit

02-1013, -1197

DEERING PRECISION INSTRUMENTS, L.L.C.,

Plaintiff-Appellant,

v.

VECTOR DISTRIBUTION SYSTEMS, INC.
and GRAM PRECISION SCALES, INC.,

Defendants-Cross Appellants,

and

MOHAN THADANI,

Defendant,

and

BONSO ELECTRONICS INTERNATIONAL, INC.,

Defendant.

Lynn H. Murray, Grippo & Elden, of Chicago, Illinois, argued for plaintiff-appellant. With her on the brief was R. David Donoghue. Of counsel was Laura K. McNally.

Michael J. Fink, Greenblum & Bernstein, P.L.C., of Reston, Virginia, argued for defendants-cross appellants.

Appealed from: United States District Court for the Northern District of Illinois

Senior Judge Harry D. Leinenweber

United States Court of Appeals for the Federal Circuit

02-1013, -1197

DEERING PRECISION INSTRUMENTS, L.L.C.,
Plaintiff-Appellant,

v.

VECTOR DISTRIBUTION SYSTEMS, INC.
and GRAM PRECISION SCALES, INC.,

Defendants-Cross-Appellants,

and

MOHAN THADANI,
Defendant,

and

BONSO ELECTRONICS INTERNATIONAL, INC.,
Defendant.

DECIDED: October 17, 2003

Before BRYSON, GAJARSA, and PROST, Circuit Judges.

GAJARSA, Circuit Judge.

Deering Precision Instruments, L.L.C. ("Deering") appeals from the judgment issued by the United States District Court for the Northern District of Illinois granting summary judgment to Vector Distribution Systems, Inc., Gram Precision Scales, Inc., Bonso Electronics International, Inc., and Mohan Thadani (collectively "Vector") of noninfringement of United States Patent No. 4,744,428 (the "428 patent"). Deering Precision Instruments, L.L.C. v. Vector Distrib. Sys., Inc., No. 01-C-1118 (N.D. Ill. Aug. 31, 2001). Vector cross-appeals the district court's denial of its motion for attorney fees. We affirm the district court's grant of summary judgment of no literal infringement. We vacate the district court's grant of summary judgment of no infringement under the doctrine of equivalents and remand for further proceedings consistent with this opinion. We affirm the district court's denial of Vector's motion for attorney fees.

I. BACKGROUND

A. Prosecution History of the '428 Patent

The '428 patent, issued to David Knotter, Donald Levin, and Jody Numbers, and assigned to Deering, is directed to a compact, light-weight, pocket-type scale capable of accurately weighing substances up to ten grams. The '428 patent issued on May 17, 1988 and has five claims, claims 1, 3, and 4 being in independent form. Claims 1, 2, 4, and 5 are at issue in the present action. Representative claim 1 recites as follows:

1. A lightweight portable scale comprising a base, a beam having a substance holder at one end thereof and a scale extending toward the opposite end thereof, a sliding weight movably carried by said beam for movement along said scale, a pair of metallic fulcrum posts projecting upwardly from said base, and a pair of metallic bearing inserts in said beam for cooperation with said fulcrum posts, one pair of the pair of posts or the pair of inserts having pointed projections thereon receivable in tapered recesses in the other pair for positioning and pivotally supporting said beam, said sliding weight being movable from a zero position to a position near the said opposite end of the beam and said sliding weight when in its zero position having a portion thereof disposed substantially in an imaginary plane containing the fulcrum of the beam, whereby to minimize the weight of the substance holder required to balance the beam when the sliding weight is in its zero position.

'428 patent, col. 6, ll. 12-30 (emphasis added).

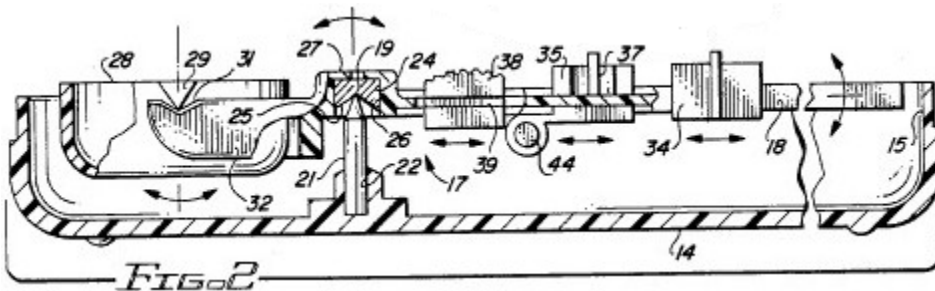

Generally, the scale of the '428 patent functions as any normal balance-type scale. As shown in Figure 2 of the '428 patent below, the scale has a bottom portion 14 that serves as a base for a weighing mechanism 17. *Id.* at col. 2, ll. 64-65. The weighing mechanism comprises a balance beam 18 mounted for pivotal movement on a pair of fulcrum posts 21. *Id.* at col. 3, ll. 3-8. The fulcrum posts are adapted to cooperate with bearing inserts 24 in the balance beam. The balance beam has a material holder 32, or tray, on one side of the fulcrum and adjustable sliding weights 34 and 35 on the opposite side of the fulcrum. *Id.* at col. 3, ll. 46-57. In operation, the weights are moved to balance the beam.

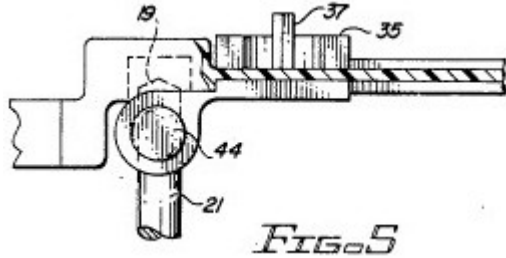

An important aspect of the invention is the minimization of the overall size and weight of the scale while maintaining the ability to weigh materials up to 10 grams. To accomplish this, the inventors designed sliding weight 35 to minimize the overall weight of the scale by moving the center of mass of the sliding weight closer to the plane created by the fulcrums of the scale. Figure 5 of the '428 patent above shows the sliding weight 35 in its zero position, i.e., the position where the beam balances without any material in the holder.

The written description provides that the sliding weight 35 be constructed in such a manner that: the heavy metallic insert 44 therein is offset from the pointer 37 of the weight in the direction of the fulcrum 19 for the balance beam 18. Indeed, the metallic insert 44 is offset to an extent that when the coarse sliding weight 35 is in its zero position, adjacent the cross-bar portion 27 of balance beam 18, the metallic insert is disposed substantially in the plane of the fulcrum 19, i.e. the imaginary vertical plane containing the center lines of the fulcrum posts 21 and 22. With the center of insert 44 aligned precisely in the plane of fulcrum 19 the insert becomes essentially neutral so far as balance of the balance beam 18 and the holder 28 are concerned when the weight 35 is in its zero position and the holder 28 is empty. This greatly minimizes the amount of mass that must be incorporated into the holder 28 portion of the weighing mechanism 17.

Id. at col. 5, ll. 12-29 (emphases added).

The application filed with the United States Patent and Trademark Office ("PTO") that matured as the '428 patent initially contained ten claims, claims 1 and 9 being in independent form. Original independent claim 1 defined a light-weight portable scale having a base, a beam with a substance holder at one end and a scale extending in an opposite direction, a sliding weight movably carried by the beam for movement along the scale, a pair of metallic fulcrum posts projecting upwardly from the base, and a pair of metallic bearing inserts in the beam for cooperation with the fulcrum posts.

Original independent claim 9 was similar to original independent claim 1, with the additional limitation that when the sliding weight is in the zero position, a portion of the sliding weight was "disposed substantially in an imaginary plane containing the fulcrum of the beam." The parties refer to this limitation as the "Zero Position Limitation."

Original claim 3, dependent on claim 1, similarly included the Zero Position Limitation:

3. The portable scale of Claim 1 further characterized in that said sliding weight is movable from a zero position to a position near the said opposite end of the beam and said sliding weight when in its zero position has a portion thereof disposed substantially in an imaginary plane containing the fulcrum of the beam, whereby to minimize the weight of the substance holder required to balance the beam when the sliding weight is in its zero position.

(emphasis added.) The Zero Position Limitation was thus the only additional limitation in dependent claim 3.

After review of the application, the PTO rejected claims 1, 2, and 5-7 under 35 U.S.C. § 103(a) as being obvious over U.S. Patent No. 4,050,531 in view of U.S. Patent No. 3,082,833. The PTO objected to claims 3, 4, and 8-10, but indicated that they would be allowable if rewritten in independent form.

The applicants filed a response to the rejection deleting original claims 1 and 3. They submitted new claim 11, which was original claim 3 rewritten in independent form. With respect to original claim 9, which had not been rejected, the applicants stated:

It is believed that the Examiner must have overlooked the fact that Claim 9 is an independent base claim and that Claim 10 is dependent only from Claim 9. Claim 9 calls for a "sliding weight when in its zero position having a portion thereof disposed substantially in an imaginary plane containing the fulcrum of the beam." This feature is not disclosed in the references. It is therefore believed that Claims 9 and 10 are allowable as written.

(emphasis added.)

The PTO subsequently issued the patent on May 17, 1998. Claim 11 issued as independent claim 1 and original claim 9 issued as claim 4.

B. Alleged Infringing Product

Vector manufactures and sells the accused device, its own version of a pocket-size scale, the VX-10. The VX-10 is shown in Figures 1 and 2 below.

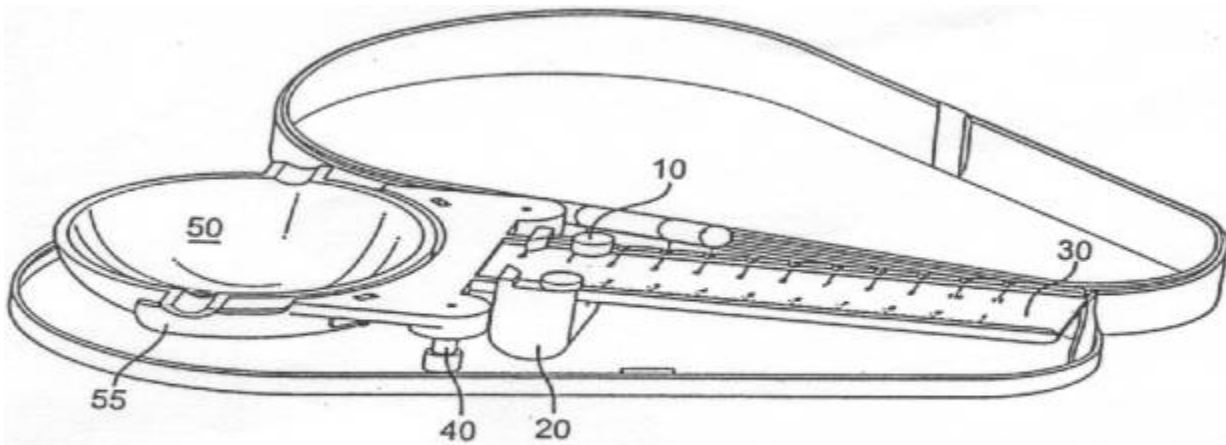

FIG. 1

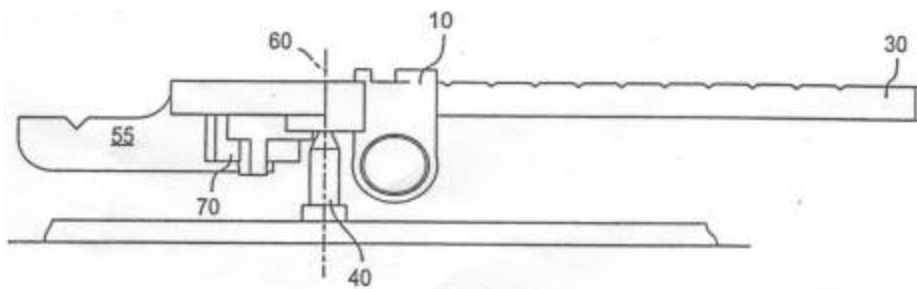

FIG. 2

The VX-10 has two slidable weights 10 and 20, each of which is movable along the balance beam 30 of the scale. The metallic insert of the sliding weight 20 is positioned directly beneath the pointer. The sliding weights of the VX-10, when in their respective "zero positions" have no portion extending into the imaginary plane containing the fulcrum 40. At its "zero position," the sliding weights 10 and 20 of the VX-10 are no closer than 0.10 inches from the imaginary plane 60 containing the fulcrum 40. The VX-10 has an additional stationary counterweight 70 affixed to the substance holder support member 55. This additional counterweight balances the scale in the zero position as opposed to

the '428 patent, which places the majority of the center of mass of the weight substantially in the plane of the fulcrum. The additional counterweight 70 coupled with the placement of the sliding weights 10 and 20 outside the plane containing the fulcrum are the decisive design differences between the VX-10 and the '428 patent for the purposes of this action.

C. Procedure Before the United States District Court

In 2001, Deering discovered Vector was selling a pocket-size scale and sued Vector for infringement. In its action, Deering sought an injunction and damages for the sale of the VX-10, alleging that the VX-10 infringed claims 1, 2, 4, and 5 of the '428 patent. Vector filed its Answer and Counterclaim on April 24, 2001 and a motion for summary judgment of noninfringement on May 25, 2001.

In connection with the summary judgment motion, Vector conceded that the VX-10 met each and every limitation of the asserted claims except for the Zero Position Limitation. The district court did not conduct a separate Markman hearing, but construed that particular limitation "to mean that the weight must enter and penetrate the imaginary plane containing the fulcrum of the beam." In arriving at this construction, the district court relied on the intrinsic evidence of the '428 patent, including the claims and the written description, as well as the ordinary meaning of the term "substantially." The district court specifically stated:

In common usage, "substantially" means significantly or considerably. In the claims at issue, the word "substantially" describes how the weight is "disposed" in the "imaginary plane." The specification sheds further light on the proper construction when, in reference to the relationship between the weight and the imaginary plane, it states that the metallic insert "rests essentially in the plane of the fulcrum for the balance beam." . . . Thus, the court construes the element requiring the sliding weight to be "disposed substantially in an imaginary plane containing the fulcrum" to mean that the weight must enter and penetrate the imaginary plane containing the fulcrum of the beam.

In light of this claim construction, the district court determined that the VX-10 did not literally infringe any of the asserted claims of the '428 patent. Specifically, the district court held, "[a]s Deering does not argue that any portion of the weight in Vector's scale enters the plane of the fulcrum, there cannot be literal infringement."

The district court also held that because the applicants amended the Zero Position Limitation

during prosecution by deleting original claim 1, this court's decision in Festo Corp. v. Shoketsu Kinzoku Kogyo Kabushiki Co., 234 F.3d 558 (Fed. Cir. 2000) (en banc) ("Festo I"), vacated by 522 U.S. 722 (2002) ("Festo II"), bars any equivalents for the Zero Position Limitation for every asserted claim. The district court recognized that independent claim 4 and dependent claim 5 were not amended during prosecution, but nevertheless determined Deering was barred from asserting the doctrine of equivalents for claims 4 and 5 because of this court's decision in Builders Concrete, Inc. v. Bremerton Concrete Products Co., 757 F.2d 255 (Fed. Cir. 1985). The district court held that prosecution history estoppel applies to any limitation narrowed during prosecution in all claims in the patent regardless of whether the limitation is present in a claim that itself was never amended.

After Vector obtained summary judgment, it moved for an award of attorney fees pursuant to 35 U.S.C. § 285. Vector argued that Deering failed to consult with a patent attorney to properly evaluate the prosecution history and that the purpose of the litigation was to harass, intimidate, or financially undermine Vector. The district court determined that failure to obtain advice of intellectual property counsel with respect to infringement under the doctrine of equivalents was not per se gross negligence and also determined that Deering's conduct was "far from harassing, intimidating, or overbearing behavior." Accordingly, the district court denied Vector's motion.

Both parties timely appealed to this court and we have jurisdiction pursuant to 28 U.S.C. § 1295 (a)(1).

II. DISCUSSION

We review the grant of summary judgment de novo, drawing all factual inferences in favor of the nonmoving party. Anderson v. Liberty Lobby, Inc., 477 U.S. 242, 255 (1986); Moore U.S.A., Inc. v. Standard Register Co., 229 F.3d 1091, 1105 (Fed. Cir. 2000). Claim construction is a question of law subject to de novo review on appeal. Cybor Corp. v. FAS Techs., Inc., 138 F.3d 1448, 1456 (Fed. Cir. 1998) (en banc).

The determination of whether a case is exceptional and thus eligible for an award of attorney fees under 35 U.S.C. § 285 is a factual determination reviewed for clear error. Superior Fireplace Co. v. Majestic Prods. Co., 270 F.3d 1358, 1376 (Fed. Cir. 2001). The subsequent determination of whether attorney fees are appropriate is reviewed for an abuse of discretion. Id.

An infringement analysis, whether literal or under the doctrine of equivalents, requires two steps: (1) construction of the claims to determine the scope and meaning of the asserted claims; and (2) comparison of the properly construed claims with the allegedly infringing device. Cybor, 138 F.3d at 1454.

A. Claim Construction

In construing the claims of a patent, we review the intrinsic evidence, which consists of the specification and the prosecution history. Interactive Gift Express, Inc. v. CompuServe, Inc., 256 F.3d 1323, 1329 (Fed. Cir. 2001). Claim construction analysis begins with the ordinary meaning of the disputed claim term. Tex. Digital Sys., Inc. v. Telegenix, Inc., 308 F.3d 1193, 1206 (Fed. Cir. 2002); Vitronics Corp. v. Conceptoronic, Inc., 90 F.3d 1576, 1582 (Fed. Cir. 1996). Generally speaking, we indulge a "strong presumption" that a claim term carries its ordinary and customary meaning. Tate Access Floors, Inc. v. Interface Architectural Res., Inc., 279 F.3d 1357, 1369 (Fed. Cir. 2002).

The next step is to review the written description and the prosecution history, to determine if the patentee has chosen to be his or her own lexicographer, or when the claim language itself lacks sufficient clarity to ascertain the scope of the claims. Prima Tek II, L.L.C. v. Polypap S.A.R.L., 318 F.3d 1143, 1148 (Fed. Cir. 2003); Ecolab, Inc. v. Envirochem, Inc., 264 F.3d 1358, 1366 (Fed. Cir. 2001); Gart v. Logitech, 254 F.3d 1334, 1339-40 (Fed. Cir. 2001).

In the present appeal, Deering contests the district court's construction of the Zero Position Limitation: "said sliding weight when in its zero position having a portion thereof disposed substantially in an imaginary plane containing the fulcrum of the beam." The Zero Position Limitation is present in every claim at issue in this action. In particular, Deering objects to the construction of the terms "substantially in an imaginary plane." It specifically contends that the term "substantially" means "at or near."

This court is asked, once again, to construe the meaning of the term "substantially" in a patent claim. See, e.g., Epcon Gas Sys., Inc. v. Bauer Compressors, Inc., 279 F.3d 1022 (Fed. Cir. 2002) (construing the terms "substantially constant" and "substantially below"); Zodiac Pool Care, Inc. v. Hoffinger Indus., Inc., 206 F.3d 1408 (Fed. Cir. 2000) (construing the term "substantially inward");

York Prods., Inc. v. Cent. Tractor Farm & Family Ctr., 99 F.3d 1568 (Fed. Cir. 1996) (construing the term "substantially the entire height thereof"); Tex. Instruments Inc. v. Cypress Semiconductor Corp., 90 F.3d 1558 (Fed. Cir. 1996) (construing the term "substantially in the common plane"). In conducting this analysis, we begin with the ordinary meaning of the claim terms to one of ordinary skill in the art. Prima Tek, 318 F.3d at 1148. Reference to dictionaries and our cases indicates that the term "substantially" has numerous ordinary meanings. As the district court stated, "substantially" can mean "significantly" or "considerably." The term "substantially" can also mean "largely" or "essentially." Webster's New 20th Century Dictionary 1817 (1983). Indeed, our cases recognize the dual ordinary meaning of this term as connoting a term of approximation or a term of magnitude. See Epcon, 279 F.3d at 1031 ("The phrase 'substantially constant' denotes language of approximation, while the phrase 'substantially below' signifies language of magnitude, i.e., not insubstantial.").

Since the term "substantially" is capable of multiple interpretations, we turn to the intrinsic evidence to determine which interpretation should be adopted. Ecolab, 264 F.3d at 1366; Gart, 254 F.3d at 1339-40.

As is often the case, the written description does not explicitly identify the meaning of the term "substantially." The specification does, however, provide the public with a significant explanation of the criticality of the location of the sliding weight in conjunction with the plane created by the fulcrum so as to support a finding that the term "substantially" is a term of magnitude as opposed to approximation. First, the stated object of the '428 patent is to provide a lightweight, portable scale. The written description plainly states:

To hold down on the mass of the substance holder portion of the mechanism required to achieve equilibrium of the mechanism the sliding weight is constructed in such a manner that the metallic insert therein rests essentially in the plane of the fulcrum for the balance beam when the sliding weight is in its zero position.

'428 patent, col. 1, ll. 48-54 (emphasis added). Figure 5, supra, shows an example of the position of the sliding weight that meets the limitation. In Figure 5, the metal insert of the sliding weight is precisely in the plane, as the written description states:

With the center of insert 44 aligned precisely in the plane of fulcrum 19 the insert becomes essentially neutral so far as balance of the balance beam 18 and the holder 28

are concerned when the weight 35 is in its zero position and the holder 28 is empty. This greatly minimizes the amount of mass that must be incorporated into the holder 28 portion of the weighing mechanism 17.

Id. at col. 5, ll. 12-29 (emphasis added). The placement of a portion of the weight in the plane of the fulcrum is the stated structural orientation that provides the benefits of minimization of weight and portability. The preferred embodiment places the center of the insert—clearly the major contributor to the total mass of the weight—precisely in the plane. We, however, do not generally limit claims to the preferred embodiment. Comark Communications, Inc. v. Harris Corp., 156 F.3d 1182, 1187 (Fed. Cir. 1998). This is particularly significant because the claim language does not contain the explicit requirement that the metal insert of the weight be "essentially in the plane" containing the fulcrum.

It is proper, however, to construe the term "substantially in the plane" in light of the specification. Apex Inc. v. Raritan Computer, Inc., 325 F.3d 1364, 1373 (Fed. Cir. 2003) ("[C]laims are interpreted in light of the specification and with the knowledge of one of ordinary skill in the art."); Vitronics, 90 F.3d at 1582. The written description, as a whole, clearly requires that a portion of the metal insert of the weight penetrate the imaginary plane containing the fulcrum of the beam to minimize the weight of the scale and facilitate portability. There is no disclosure suggesting that a portion of the weight need only be located at or near the plane as Deering suggests. For this reason, we agree in part with the district court's construction of the Zero Position Limitation as requiring at least a portion of the weight to intersect the plane containing the fulcrum. We agree with the district court's claim construction only in part because the district court's construction effectively reads the term "substantially" out of the claims by construing the claim to read on any slight penetration of the plane. This error, however, is harmless because, as discussed above, the term "substantially" is a term of magnitude requiring a "not insubstantial" portion of the weight to intersect the plane containing the fulcrum. Epcon, 279 F.3d at 1031. Because this construction is actually narrower than the district court's construction, it does not affect the district court's ultimate finding of noninfringement with respect to the VX-10. Accordingly, in light of the ordinary meaning of the term "substantially" and in view of the written description, we construe the Zero Position Limitation as requiring a not insubstantial portion of the weight to intersect the plane containing the fulcrum.

On appeal, Deering argues that the term "substantially in" means "at or near the imaginary

plane." Deering argues that any other interpretation reads the term "substantially," one of approximation, out of the claim. As discussed above, the term "substantially" in this context is used as a term of magnitude, describing the extent of the portion of the weight in the plane defined by the fulcrum, not as a term of approximation.

B. Infringement

The second step of the infringement analysis requires comparison of the accused device to the properly construed claims. Cybor, 138 F.3d at 1454. To prove infringement, the patentee must show that the accused device meets each claim limitation, either literally or under the doctrine of equivalents. Seal-Flex, Inc. v. Athletic Track & Court Constr., 172 F.3d 836, 842 (Fed. Cir. 1999).

With respect to literal infringement, it is clear that the VX-10 does not literally meet each limitation of any of the asserted claims 1, 2, 4, and 5 of the '428 patent. In particular, the accused device does not penetrate the imaginary plane at any point, and therefore does not literally infringe the asserted claims of the '428 patent. Deering admits this by arguing that the placement of the weight 0.10 inches away from the plane amounts to literal infringement. In short, because no portion of the weight of the VX-10 is "substantially in" the plane under either the district court's or our narrower construction, the VX-10 cannot literally infringe the claims of the '428 patent.

With respect to the doctrine of equivalents, the district court relied on this court's holding in Festo I to determine that Deering was estopped from asserting infringement under the doctrine of equivalents. Festo I was vacated by the Supreme Court in Festo II. Accordingly, we vacate the district court's finding of no infringement under the doctrine of equivalents based on Festo I and address whether prosecution history estoppel, as discussed in the Supreme Court's decision in Festo II, and this court's opinion on remand, Festo Corp. v. Shoketsu Kinzoku Kogyo Kabushiki Co., ___ F.3d ___ (Fed. Cir. Sept. 26, 2003) (en banc) ("Festo III"), is applicable to the claims at issue.

The parties dispute whether prosecution history estoppel applies to Deering's allegations of infringement under the doctrine of equivalents. There are two distinct theories that fall under the penumbra of prosecution history estoppel—amendment-based estoppel and argument-based estoppel. Elkay Mfg. Co. v. Ebco Mfg. Co., 192 F.3d 973, 979 (Fed. Cir. 1999) (holding that the scope of

coverage of the claims may change if a patentee has "relinquished [a] potential claim construction in an amendment to the claim or in an argument to overcome or distinguish a reference"). In general, prosecution history estoppel, under either theory, requires that patent claims be interpreted in light of the proceedings before the PTO. Festo II, 535 U.S. at 733.

1. Amendment-based Estoppel

With respect to amendment-based estoppel, "a narrowing amendment made to satisfy any requirement of the Patent Act may give rise to an estoppel." Id. at 736. "A patentee's decision to narrow his claims . . . may be presumed to be a general disclaimer of the territory between the original claim and the amended claim." Id. at 740. When the patentee originally claimed the subject matter alleged to infringe but then narrowed the claim in response to a rejection, "courts may presume the amended text was composed with awareness of this rule and that the territory surrendered is not an equivalent of the territory claimed. In those instances, however, the patentee must show that at the time of the amendment one skilled in the art could not reasonably be expected to have drafted a claim that would have literally encompassed the alleged equivalent." Id. at 741. This can be shown by one of the following three criteria: (1) the equivalent may have been unforeseeable at the time of the amendment; (2) the rationale underlying the amendment may bear no more than a tangential relation to the equivalent in question; or (3) there may be some other reason suggesting that the patentee could not reasonably be expected to have described the insubstantial substitute in question. Festo III, ___ F.3d at ___.

As an initial note, the only asserted independent claim that is arguably subject to a narrowing amendment during prosecution is issued claim 1. This claim, filed as claim 11, essentially incorporated original claim 1 and original dependent claim 3. Original claim 9 was not amended during prosecution and issued as independent claim 4 in unamended form. In response to the first Office Action rejecting claim 1 under 35 U.S.C. § 103(a) and objecting to claim 3 because it depended from rejected claim 1, the applicants deleted claims 1 and 3 and added new independent claim 11.

Deering's addition of independent claim 11, coupled with the clear surrender of the broader subject matter of the deleted original independent claim presumptively bars Deering from arguing infringement under the doctrine of equivalents. As the Supreme Court noted, the correct focus is on

whether amendment surrendered subject matter that was originally claimed for reasons related to patentability. Festo II, 535 U.S. at 736. Here, the patentees clearly disclaimed the territory between the original claim 1 and new claim 1 as issued. Id. at 740. Original claim 1 claimed "a sliding weight movably carried by said beam for movement along said scale." In response to the examiner's rejection under 35 U.S.C. § 103(a), the applicants deleted original claims 1 and 3 and settled for claims containing the narrower requirement that a portion of the sliding weight be disposed substantially in a plane defined by the fulcrums originally present in claim 3. The territory between the sliding weight limitation of original claim 1 and the Zero Position Limitation was thus surrendered by the patentees. See Pioneer Magnetics, Inc. v. Micro Linear Corp., 330 F.3d 1352, 1357 (Fed. Cir. 2003).

In Festo II, the Supreme Court stated "[e]stoppel arises when an amendment is made to secure the patent and the amendment narrows the patent's scope." Id. at 736. Accordingly, we hold that because Deering narrowed the Zero Position Limitation for reasons related to patentability, the presumption of prosecution history estoppel set forth by the Supreme Court in Festo II applies to independent claim 1 and dependent claim 2.

While Deering argues that it merely rewrote an allowable original claim 3 in independent form, there is no question that the claim was narrowed by the deletion of a broad original claim in favor of a claim that contained the Zero Position Limitation. Because the amendment in this case is not "truly cosmetic," estoppel presumptively applies. Id. at 736-37.

Additionally, this presumption applies to all claims containing the Zero Position Limitation, regardless of whether the claim was, or was not, amended during prosecution. Builders Concrete, 757 F.2d at 260 (holding that prosecution history estoppel applies to a claim containing a limitation that was allowed as originally filed based on the addition of the same limitation in a separate claim). Here, as in Builders Concrete, independent claim 4 contained the disputed limitation and was never amended during prosecution. Nevertheless, it is clear from the prosecution history that the allowance of claim 1, the broadest claim, depended on the amendment narrowing the Zero Position Limitation to that of a dependent claim. Since independent claim 4 and dependent claim 5 contain the Zero Position Limitation, prosecution history estoppel presumptively applies equally to those claims. Id. "To hold otherwise would be to exalt form over substance and distort the logic of this jurisprudence, which serves

as an effective and useful guide to the understanding of patent claims." Id.

The remaining question is whether Deering can rebut the Festo II presumption. This question is better addressed in the first instance by the district court. Schwing GMBH v. Putzmeister Aktiengesellschaft, 305 F.3d 1318, 1329 (Fed. Cir. 2002) (remanding the rebuttal of a Festo II presumption to the district court for a determination in the first instance). Accordingly, we remand the rebuttal issue to the district court for further proceedings consistent with this opinion and with this court's en banc decision in Festo III.

2. Argument-based Estoppel

With respect to argument-based estoppel, Vector contends that arguments made during prosecution estop Deering from asserting infringement under the doctrine of equivalents. "To invoke argument-based estoppel, the prosecution history must evince a 'clear and unmistakable surrender of subject matter.'" Eagle Comtronics, Inc. v. Arrow Communication Labs., Inc., 305 F.3d 1303, 1316 (Fed. Cir. 2002) (quoting Pharmacia & Upjohn Co. v. Mylan Pharms., Inc., 170 F.3d 1373, 1376-77 (Fed. Cir. 1999)).

As described above, the Examiner objected to original claim 9 and indicated its allowability if rewritten in independent form although original claim 9 was already in independent form. In response, the applicants noted the Examiner's mistake and restated the Zero Position Limitation as not being disclosed in the references of record. This statement is merely a clarification of the Examiner's mistake, not the "clear and unmistakable surrender of subject matter" required by this court in Eagle Comtronics. Accordingly, we hold that argument-based estoppel was not a proper basis for applying prosecution history estoppel. Upon remand, should Deering adequately rebut the presumption discussed above, Deering shall not be estopped from arguing that the VX-10 infringes claim 4 of the '428 patent based on arguments made in prosecution.

C. Cross-appeal

Finally, on cross-appeal Vector argues that the district court committed clear error when it declined to consider the case exceptional for the purpose of awarding attorney fees under 35 U.S.C.

§ 285. It argues that Deering was grossly negligent in failing to consult the prosecution history prior to bringing this action. Moreover, Vector also argues that Deering brought this lawsuit for purposes of harassment. The district court addressed each of these arguments in its decision, and we review the district court's exceptionality determination for clear error. Superior Fireplace, 270 F.3d at 1376. Because it was not clearly erroneous for the district court to find the case unexceptional, Vector's argument must fail. Without the initial finding of an exceptional case, there can be no abuse of discretion by the district court in denying attorney fees. Id. We therefore affirm the district court's finding that this was not an exceptional case.

III. CONCLUSION

For the foregoing reasons, we hold that Vector was properly granted summary judgment of no literal infringement of the '428 patent. We vacate the district court's grant of summary judgment of no infringement under the doctrine of equivalents and remand for further proceedings in light of the Supreme Court's decision in Festo II and this court's decision in Festo III. Lastly, we affirm the district court's denial of attorney fees.

AFFIRMED-IN-PART, VACATED-IN-PART, AND REMANDED.

IV. COSTS

Each party to bear its own costs.