

**United States Court of Appeals  
for the Federal Circuit**

---

**TESSERA, INC.,**  
*Appellant,*

v.

**INTERNATIONAL TRADE COMMISSION,**  
*Appellee,*

AND

**ELPIDA MEMORY, INC. AND ELPIDA MEMORY  
(USA) INC.,**  
*Intervenors,*

AND

**SMART MODULAR TECHNOLOGIES, INC.,**  
*Intervenor,*

AND

**ACER, INC., ACER AMERICA CORPORATION,  
NANYA TECHNOLOGY CORPORATION, NANYA  
TECHNOLOGY CORPORATION U.S.A.,  
AND POWERCHIP SEMICONDUCTOR  
CORPORATION (now known as Powerchip Tech-  
nology Corporation),**  
*Intervenors,*

AND

**RAMAXEL TECHNOLOGY LTD.,**  
*Intervenor,*

AND  
**KINGSTON TECHNOLOGY COMPANY, INC.,**  
*Intervenor.*

---

2010-1176

---

On appeal from the United States International Trade  
Commission in Investigation No. 337-TA-630.

---

Decided: May 23, 2011

---

BENJAMIN W. HATTENBACH, Irell & Manella LLP, of Los Angeles, California, argued for appellant. With him on the brief were MORGAN CHU, JONATHAN H. STEINBERG, KENNETH J. WEATHERWAX and MARK A. KRESSEL; and WAYNE M. BARSKY, of Gibson, Dunn & Crutcher LLP, of Los Angeles, California; and MARK N. REITER and STEVEN M. GEISZLER, of Dallas, Texas.

PANYIN A. HUGHES, Office of the General Counsel, United States International Trade Commission, of Washington, DC, argued for appellee. With him on the brief were JAMES M. LYONS, General Counsel, and MICHELLE W. KLANCNIK, Acting Assistant Counsel.

ERIC L. WESENBERG, Orrick, Herrington & Sutcliffe, LLP, of Menlo Park, California, argued for intervenors Acer, Inc., et al. With him on the brief were KENNETH J. HALPERN, G. HOPKINS GUY III, KAI TSENG, MICHAEL F. HEAFEY and BRIAN H. VANDERZANDEN, of Menlo Park, California. Of counsel was STEVEN E. ADKINS, of Washington, DC; and SANJEET K. DUTTA, MATTHEW J. HULT, HSIANG HONG LIN, DENISE MARIE MINGRONE, and

MICHAEL C. TING, of Menlo, California; and CYNTHIA ALISON LOCK, of Irvine, California.

KENNETH E. KROSIN, Foley & Lardner, LLP, of Washington, DC, argued for intervenors Elpida Memory, et al. With him on the brief were GREGORY C. BECK, MARY M. CALKINS; and GINA A. BIBBY of Palo Alto, California; and MICHAEL R. HOUSTON, of Chicago, Illinois. Of counsel was RICHARD S. FLORSHEIM, of Milwaukee, Wisconsin.

JOSEPH V. COLAIANNI, Fish & Richardson, P.C., of Washington, DC, for intervenor Ramaxel Technology Ltd. With him on the brief was TIMOTHY W. RIFFE. Of counsel on the brief was RUIXUE RAN, Jun He Law Offices, Beijing, China.

MICHAEL R. LEVINSON, Seyfarth Shaw LLP, of Chicago, Illinois, for intervenor Kingston Technology Company, Inc. With him on the brief were ALAN L. UNIKEL, JOSEPH R. LANSER and MATTHEW A. WERBER. Of counsel on the brief was CHRISTINE YANG, Law Offices of S.J. Christine Yang, of Fountain Valley, California.

JONATHAN M. JAMES, Perkins Coie LLP, of Perkins Coie LLP, of Phoenix, Arizona, for intervenor SMART Modular Technologies Inc. Of counsel was DAVID JOHN PALMER.

---

Before LOURIE, LINN, and DYK, *Circuit Judges*.

LINN, *Circuit Judge*.

Tessera, Inc. (“Tessera”) filed a complaint with the United States International Trade Commission (the “Commission” or “ITC”) on December 21, 2007, under section 337 of the Tariff Act of 1930, 19 U.S.C. § 1337, alleging that eighteen respondents infringed U.S. Patent

Nos. 5,663,106 (the “106 patent”); 5,679,977 (the “977 patent”); 6,133,627 (the “627 patent”); and 6,458,681 (the “681 patent”) through the importation of certain semiconductor chips. See *Certain Semiconductor Chips With Minimized Chip Package Size and Products Containing Same*, No. 337-TA-630 (Int’l Trade Comm’n Aug. 28, 2009) (“*Initial Determination*”). The ’681 patent was terminated from the investigation prior to hearing. Tessera appeals from the Commission’s final determination finding no section 337 violation. *Certain Semiconductor Chips With Minimized Chip Package Size and Products Containing Same*, No. 337-TA-630 (Int’l Trade Comm’n Feb. 24, 2010) (“*Final Determination*”).

Of the eighteen respondents, ten remain in the case and have intervened in this appeal. The intervenors include Elpida Memory, Inc. and Elpida Memory (USA) Inc. (collectively, “Elpida”); Smart Modular Technologies, Inc.; Acer, Inc., Acer America Corporation, Nanya Technology Corporation, Nanya Technology Corporation USA, and PowerChip Semiconductor Corporation; Ramaxel Technology Ltd.; and Kingston Technology Company, Inc. (collectively, “Intervenors”). Because the Commission’s decision is supported by substantial evidence and is not contrary to law, this court affirms the determination of no violation with respect to the ’106 patent, and vacates as moot the Commission’s decision regarding the ’977 and ’627 patents, which have now expired.

## I. BACKGROUND

The patents-in-suit relate to innovations in semiconductor chip packaging.

### A. Technology

A semiconductor chip (“chip”) is a widely used miniaturized electronic circuit. A semiconductor package (“package”) protects these delicate chips from mechanical

and thermal damage. Most modern packages protect the chip by encapsulating it with a molded plastic, generally referred to as “encapsulant.” One problem with using encapsulant, however, is that it tends to contaminate the delicate, miniature electrical terminals on the exterior of those packages. These terminals serve as an endpoint for electrically connecting the package to another device, such as a printed circuit board. These terminals become contaminated when encapsulant obstructs the terminals, preventing an effective and reliable electrical connection. The '106 patent is directed toward innovations preventing the contamination of exposed terminals on packages during encapsulation.

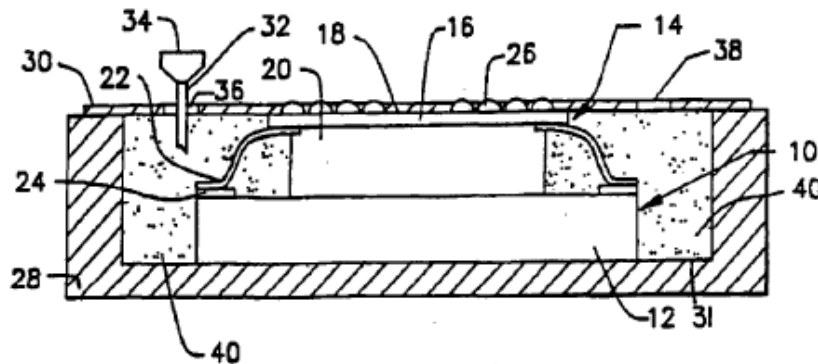

FIG. 1

Figure 1 provides an illustration of the invention described and claimed in the '106 patent. The claimed invention is directed to protecting the terminals (26) of the chip (12) from encapsulant (40). During encapsulation, the patent describes using an encapsulant barrier (28) and a protective barrier (30) to define an encapsulation area. The preferred embodiment uses a material known as “solder mask” for the protective barrier, but also permits the use of “any other means which protects the exposed terminals on the top layer.” *Id.* col.2 ll.25-26, 59-61. The protective barrier protects the terminals from

coming in contact with encapsulant (40) when it is injected into the encapsulation area through a fill hole (36).

Tessera asserted claims 1-4, 9-10, and 33-35 of the '106 patent. Claim 1, from which the other asserted claims depend, is set forth below with emphasis added to show the key limitation on appeal:

1. A method of encapsulating a semiconductor chip assembly having a *top layer* with an array of exposed terminals thereon, the terminals being electrically connected to the chip, said method comprising the steps of:

placing an encapsulant barrier adjacent the semiconductor chip assembly, said encapsulant barrier at least partially defining an encapsulation area;

providing a protective barrier in contact with said *top layer* for protecting the terminals on the *top layer* from an encapsulation material; and

introducing an encapsulation material into at least a portion of the encapsulation area so that the encapsulation material flows to fill the encapsulation area and then cures to a substantially solid condition, the protective barrier preventing the encapsulation material from contacting the terminals on the *top layer*.

*Id.* col.9 ll.32-48 (emphases added).

## B. Accused Products

Each package accused of infringing the '106 patent includes a chip and a package substrate layer. The accused products fall into two categories: a first group with a polyimide-based package substrate ("µBGA") and a second

group with a laminate-based package substrate (“wBGA”). Despite using different materials for the package substrate layer, the accused products are similar in most respects. Only Elpida imports the accused  $\mu$ BGA products, whereas all intervenors import the accused wBGA products. Because the infringement determination as to the  $\mu$ BGA is not challenged on appeal, this discussion will focus on the accused wBGA products.

The accused wBGA products consist of a stack of layers. The bottom-most relevant layer is the laminate substrate layer. This layer can be thought of as a solid foundational layer. A copper wiring layer is applied on top of this laminate substrate layer. This conductive copper wiring layer provides for the controlled flow of electrical signals. To prevent corrosion of the copper and the inadvertent shorting of the electrical paths, a solder mask layer is applied on top of the copper wiring layer. The solder mask layer covers both the copper wiring layer and the underlying laminate substrate layer, leaving exposed only the endpoints of each copper conductive path. These exposed copper endpoints—holes in the solder mask layer where the underlying copper wiring layer is exposed—are the terminals of the accused wBGA products. During encapsulation, a “protective barrier” comes in contact with the solder mask layer and prevents encapsulant from flowing into the holes on the solder mask layer and contaminating those terminals—the exposed areas of the underlying copper wiring layer.

### C. Tessera’s Licensees

Tessera’s primary business is licensing its technology. Since the late 1990s, Tessera has licensed the patents-in-suit to more than sixty semiconductor technology companies, including nine of the ten largest. Tessera often licenses its patents to suppliers through agreements called “TCC Licenses.”

While the terms of each TCC License vary from licensee to licensee, these TCC Licenses share several characteristics. Each TCC License calls for an upfront license fee along with running royalties to be paid at the end of a reporting period for products sold. Each TCC License also contains a grant clause substantially identical to the following: “Subject to the terms and conditions [of this agreement], Tessera hereby grants Licensee a . . . license to the Tessera Patents . . . and to sell . . . and/or offer for sale such TCC Licensed Products.” *Appellant’s Br.* 56. Finally, each also contains an “Exclusion from License” provision stating that “Licensee is licensed only to Licensed Products for which Licensee or a third party has satisfied a royalty obligation of Tessera.” *Id.* at 57.

All of the intervenors purchase some portion of their accused packages from parties to the TCC Licenses. Elpida asserts, and the Commission agreed, that 100% of its products came from Tessera licensees. The remaining intervenors concede that at least a small portion of their accused products are made from unlicensed suppliers. It is undisputed that some licensees had fallen behind on their obligations to pay royalties on sales made under the TCC Licenses.

#### D. Procedural History

On August 28, 2009, the presiding administrative law judge (“ALJ”) issued the *Initial Determination*, finding no section 337 violation. In reaching this conclusion, the ALJ determined: (1) Tessera failed to meet its burden to show that the accused products infringed the ’106, ’977, and ’627 patents; (2) the ’106 patent was not invalid for anticipation, obviousness, or indefiniteness; (3) the ’977 and ’627 patents were not invalid for anticipation or indefiniteness; and (4) Tessera’s patent rights are exhausted as to those accused products purchased from Tessera’s licensees. *Id.*



On October 30, 2009, the Commission decided to review, among other issues, the ALJ's findings regarding claim construction of two terms recited in claim 1 of the '106 patent: "top layer" and "thereon." *In the Matter of Certain Semiconductor Chips with Minimized Chip Package Size and Products Containing Same*, Notice of Commission Determination To Review in Part a Final Initial Determination Finding No Violation of Section 337 (Oct. 30, 2009) ("*Notice to Review*"). Among the issues the Commission decided not to review was the ALJ's finding of patent exhaustion. *Id.*

After briefing by the parties, the Commission issued its final determination on January 4, 2010. In affirming the ALJ's determination of no section 337 violation, the Commission: (1) modified the ALJ's construction of "top layer" and "thereon" in claim 1 of the '106 patent; (2) reversed the ALJ's finding of noninfringement for the  $\mu$ BGA products, but affirmed his finding of patent exhaustion; and (3) affirmed the ALJ's finding that the accused wBGA products do not infringe the asserted claims of the '106 patent. *Final Determination*. Thus, the Commission found that the  $\mu$ BGA products infringe, but are exhausted, and that the wBGA products do not infringe.

Tessera appeals from the *Final Determination* on multiple grounds. First, Tessera challenges the Commission's claim construction of claim 1 of the '106 patent. Second, Tessera challenges the Commission's finding of no infringement by the accused wBGA products. Third, Tessera challenges the Commission's finding of patent exhaustion. Finally, Tessera seeks a vacatur of the Commission's decision as it pertains to the now expired '977 and '627 patents. On appeal, a few intervenors have also challenged the validity of the '106 patent as being anticipated by numerous prior art references. This court has jurisdiction under 28 U.S.C. § 1295(a)(6).

## II. DISCUSSION

### A. Standard of Review

This court reviews the Commission’s legal determinations *de novo* and the Commission’s factual findings for substantial evidence. *Alloc, Inc. v. Int’l Trade Comm’n*, 342 F.3d 1361, 1368 (Fed. Cir. 2003). This court “must affirm a Commission determination if it is reasonable and supported by the record as a whole, even if some evidence detracts from the Commission’s conclusion.” *Nippon Steel Corp. v. United States*, 458 F.3d 1345, 1352 (Fed. Cir. 2006) (internal quotation marks omitted).

### B. Claim Construction

Tessera argues that the Commission initially adopted a correct claim construction, but “halfway through its infringement analysis, the ITC inexplicably switched to an incorrect claim construction.” *Appellant’s Br.* 25. According to Tessera, this court should therefore review the Commission’s finding of non-infringement *de novo*, as an error in claim construction. Intervenors and the Commission respond that Tessera “attempts to transform the Commission’s factual infringement finding into a claim construction issue in order to receive *de novo* review.” *Appellee’s Br.* 20.

“Patent infringement is a two step inquiry. First, the court must construe the asserted claim . . . . Second, the court must determine whether the accused product or process contains each limitation of the properly construed claims.” *Freedman Seating Co. v. Am. Seating Co.*, 420 F.3d 1350, 1356-57 (Fed. Cir. 2005). Claim construction is an issue of law this court reviews *de novo*. *Cybor Corp. v. FAS Techs., Inc.*, 138 F.3d 1448, 1456 (Fed. Cir. 1998) (en banc). Because the second step, applying a proper construction to the accused products in reaching a determination as to infringement, is a question of fact, this court

reviews for substantial evidence. *Freedman*, 420 F.3d at 1357.

Tessera does not, nor could it, argue that the Commission adopted an incorrect claim construction. This is because the Commission adopted Tessera's proposed claim construction. *See Final Determination* at 16-24. Tessera's contention at best is a disagreement over the Commission's *application* of Tessera's construction to the accused wBGA devices. This court therefore agrees with Intervenor and the Commission that Tessera is challenging the Commission's infringement determination, which this court reviews for substantial evidence.

### C. Infringement

Tessera argues that the Commission erred in finding that the accused wBGA products do not infringe claim 1 of the '106 patent. Specifically, Tessera argues that the Commission erred when it found that the "top layer" of claim 1 cannot include the solder mask layer of the accused wBGA products. In doing so, according to Tessera, the Commission improperly modified its construction of "top layer." The Commission construed "top layer" to mean "a layer disposed on the active side of the chip and which carries the terminals." *Final Determination* at 20. Because the construction does not explicitly exclude "solder mask," Tessera argues that the Commission erred by refusing to consider the accused solder mask layer as part of the claimed "top layer."

According to Tessera, the Commission should have found the top layer to be either: (1) the solder mask layer, or (2) a composite "layer" that includes both the laminate substrate and solder mask layers. Tessera argues that the "top layer" must include the solder mask layer of the accused wBGA products because the terminals are on the bottom edge of the solder mask layer. Tessera goes on to

argue that because the “protective barrier” comes in contact with the solder mask during production of the accused wBGAs, had the Commission found that the solder mask was part of the “top layer,” the accused wBGA products would infringe.

Intervenors and the Commission respond that substantial evidence supports the Commission’s finding. The Commission found that the laminate substrate layer of the accused wBGA products corresponded to the “top layer” in claim 1 of the ’106 patent. Under the adopted construction, the “top layer” is the layer that “carries the terminals.” Intervenors’ expert testified that the copper wiring layer overlays the substrate core layer. The “terminals” are simply the exposed areas of the copper wiring layer. Only after the copper wiring layer is applied on top of the laminate substrate layer is the solder mask layer applied to the assembly. Thus, according to Intervenors and the Commission, the solder mask layer does not “carry the terminals” and cannot be the “top layer.” Even though the terminals may be “thereon,” i.e., adjacent to the bottom surface of, the solder mask layer, the solder mask layer does not “carry the terminals.” *See Final Determination* at 20-21. Rather, under Tessera’s own construction, the “top layer” must “carry the terminals.” In the accused wBGA products, Intervenors contend that substantial evidence supports the Commission’s conclusion that the layer which “carries the terminals” is the laminate substrate layer. They conclude by arguing that because it is undisputed that the “protective barrier” comes in contact not with the laminate substrate layer, but instead with the solder mask layer, the limitation “providing a protective barrier in contact with said top layer” is not satisfied, and the accused wBGA products do not infringe.

Substantial evidence supports the Commission’s determination that the laminate substrate layer of the

accused wBGA products is the “top layer” and, as such, these products do not infringe the asserted claims of the ’106 patent. The issue of infringement ultimately turns upon which layer is identified as the “top layer.” The ALJ issued a detailed opinion, citing expert testimony, explaining how the terminals are formed on the laminate substrate layer and how the laminate substrate layer is that layer which carries the terminals, or, the “top layer.” *Initial Determination* at 50 (“[T]he evidence clearly shows that the [terminals] are formed from the copper metallization layer that is [thereon] the [laminate] substrate for wBGA products.”).

In applying the modified construction to the accused wBGA products, the Commission found “the ALJ correctly concluded that for the wBGA packages, the laminate-based substrate core layer represents the claimed ‘top layer,’ and that because the ‘protective barrier’ does not come into contact with that layer, the wBGA packages do not infringe the asserted claims of the ’106 patent.” *Final Determination* at 28. We see no basis to question the factual finding that the laminate substrate layer is the layer that “carries the terminals.”

For further support, the Commission noted that throughout the specification, “solder mask” is depicted as a component separate and distinct from the “top layer.” *Final Determination* at 27-28 (stating “[n]owhere does the ’106 patent describe or suggest that the top layer includes the solder mask layer”). Tessera argues that the Commission, in doing so, improperly imported a “no solder mask” limitation into its claim construction. This court remains unconvinced. The Commission did not modify its claim construction or import limitations from the specification. Instead, the Commission simply noted that Tessera’s theory of infringement, requiring the claimed “top layer” to include the solder mask layer, was flatly inconsistent with the preferred embodiment depicted in

the '106 patent. Indeed, the specification describes using “solder mask” as the preferred material for the protective barrier, not the top layer, and, at times, even uses the term “solder mask” interchangeably with “protective barrier.” '106 patent at col.2 ll.25-26 (“Preferably, the protective barrier utilized in the present invention is a solder mask.”). It is disingenuous for Tessera to argue that the solder mask layer on the accused wBGA products is part of the “top layer” when the patent describes “solder mask” as the preferred material for the “protective barrier” and depicts the “protective barrier” as separate and distinct from the “top layer.” *See, e.g., id.* at Fig.1.

Tessera fails to cite any record evidence supporting its contention that the solder mask layer “carries the terminals.” Substantial evidence supports the Commission’s finding that the claimed “top layer,” the layer that “carries the terminals,” corresponds to the laminate substrate layer on the accused wBGA products. *See Final Determination* at 28. In light of this finding, the accused wBGA products do not infringe the asserted claims of the '106 patent. This court therefore affirms the Commission’s finding of no infringement as to the accused wBGA products.

#### D. Anticipation

Intervenors argue that the Commission incorrectly found that the asserted claims of the '106 patent were not anticipated by U.S. Patent Nos. 5,136,336 (“Worp”), 5,218,759 (“Juskey”), and 4,868,349 (“Chia”). Tessera responds that numerous claim elements are absent from each reference.

Anticipation is a question of fact that must be established by clear and convincing evidence. *Sanofi-Synthelabo v. Apotex, Inc.*, 550 F.3d 1075, 1082 (Fed. Cir. 2008). This court agrees with Tessera that substantial

evidence supports the Commission's determination that the asserted claims of the '106 patent are not anticipated by Worp, Juskey, or Chia.

Worp fails to disclose at least a "protective barrier in contact with said top layer," as required by claim 1 of the '106 patent. Although the ALJ found a "strong possibility" that this limitation may be present in Worp, the Intervenor fails to cite any disclosure in Worp that describes the configuration of the "protective barrier" and whether it actually contacts the top layer.

Juskey also fails to disclose at least a "protective barrier in contact with said top layer," as required by claim 1 of the '106 patent. Instead, the ALJ found that Juskey discloses the use of glue between the top layer and the protective barrier, preventing the protective barrier from coming in contact with the top layer. Intervenor fails to cite any disclosure in Juskey that shows a protective barrier in contact with the top layer.

Chia fails to disclose at least "exposed terminals," as required by claim 1 of the '106 patent. Intervenor argues that the pins in Chia serve as the exposed terminals. The ALJ, on the other hand, found that the pins in Chia are neither "terminals," because they are not an endpoint of the package, nor "exposed" to contamination, because the pins are slid into the plated-through holes prior to encapsulation. Instead, the ALJ found the plated-through holes in Chia were the terminals because they serve as the endpoint for electrical and mechanical connection from the package to the outside world. Intervenor fails to cite any disclosure in Chia of terminals exposed to contamination from encapsulant.

To invalidate the asserted claims of the '106 patent on the grounds of anticipation, the Intervenor must prove by clear and convincing evidence that a single prior art

reference discloses each and every limitation of the '106 patent. The ALJ's detailed and well reasoned analysis of the asserted prior art and his determination that the '106 patent is not anticipated is supported by substantial record evidence. This court therefore affirms the Commission's determination that the '106 patent is not anticipated by Worp, Juskey, or Chia.

### E. Patent Exhaustion

This court's affirmance of the Commission's finding of noninfringement as to the wBGA products leaves the accused  $\mu$ BGA products as the only products found to infringe the '106 patent. The finding of infringement is not challenged on appeal, but the Commission's determination of patent exhaustion is. Because Elpida is the only importer of the accused  $\mu$ BGA products, it is the only party affected by this determination.

As a preliminary matter, the Commission and Elpida challenge this court's jurisdiction to hear the appeal regarding patent exhaustion. Accordingly, this court will first address the jurisdictional challenge before addressing the merits of the underlying patent exhaustion defense.

#### 1. Jurisdiction

The Commission and Elpida argue that this court lacks jurisdiction to hear Tessera's appeal as to patent exhaustion because Tessera did not timely appeal that issue. The ALJ issued the *Initial Determination* on August 28, 2009. At that time, the ALJ determined that Tessera's patent rights were exhausted with respect to all accused products sold by Tessera's licensees. *Initial Determination*. Because the ALJ found that intervenor Elpida purchased 100% of its accused products from Tessera's licensees, Elpida could no longer be subject to an exclusion order and was terminated from the investi-



gation. On October 30, 2009, the Commission issued its *Notice to Review* announcing its decision not to review the ALJ's determination on patent exhaustion. The Commission subsequently issued its *Final Determination* on December 29, 2009.

Tessera filed a notice of appeal on January 28, 2010, within sixty days from the *Final Determination*, but more than sixty days from the *Notice to Review*. The Commission argues that when it decided not to review the ALJ's determination on patent exhaustion, the ALJ's decision then became the final decision of the Commission. Because Tessera did not file a notice of appeal within sixty days of the Commission's decision not to review the ALJ's patent exhaustion determination, the Commission argues that Tessera's appeal of that issue was not timely and, therefore, should be dismissed for lack of jurisdiction.

The Commission cites this court's decision in *Allied Corporation v. International Trade Commission*, for the proposition that a Commission decision is final when "there was no provision for . . . review . . . following a determination that does not lead to an exclusion order." 782 F.2d 982, 983-84 (Fed. Cir. 1986); *see also Broadcom Corp. v. Int'l Trade Comm'n*, 542 F.3d 984, 986 (Fed. Cir. 2008). Because the Commission decided not to review the patent exhaustion issue, nothing in the Commission's *Final Determination* could result in an exclusion order as to Elpida. Thus, the Commission argues, Tessera should have filed a notice of appeal, at least as to Elpida, when the Commission refused to review an issue dispositive of the investigation for Elpida.

Tessera responds that this court's jurisdiction over appeals from the Commission is governed by § 1337(c), which requires that "[a]ny person adversely affected by a final determination of the Commission . . . may appeal such determination, within 60 days after the determina-

tion becomes final.” 19 U.S.C. § 1337(c). Under ITC regulations, an initial determination becomes the determination of the Commission “unless the Commission . . . shall have ordered review of the initial determination or *certain issues therein . . .*” 19 C.F.R. § 210.42(h)(2) (emphasis added). According to Tessera, when the Commission decided to review “certain issues therein,” such as claim construction of the ’106 patent, the ALJ’s *Initial Determination* did not become final as to the ’106 patent.

Tessera distinguishes *Broadcom* and *Allied* as both involving undisputedly final determinations finding some patents infringed and others not infringed or invalid. In those cases, the only question was whether the patentee should appeal noninfringement or invalidity immediately or wait for the Presidential review period to pass as to the patent held valid and infringed. *Broadcom*, 542 F.3d at 894; *Allied*, 782 F.2d at 983-84. Tessera further argues that requiring an immediate appeal from the Commission’s *Notice to Review* in this case, where the Commission decided not to review certain affirmative defenses to patent infringement, would result in piecemeal appeals. *See, e.g., United States v. Hollywood Motor Co.*, 458 U.S. 263, 265 (1982) (disfavoring piecemeal appeals disfavored).

*Allied* is easily distinguished. There, the ALJ found one patent not invalid and infringed but held the other two asserted patents invalid. *Allied*, 782 F.2d at 983. The Commission subsequently adopted the ALJ’s findings and issued an exclusion order as to the valid and infringed patent. *Id.* The issue was whether *Allied* should have appealed the invalidity determination when the Commission adopted the ALJ’s findings or, instead, after the Presidential review period passed for the patent held valid and infringed. *Id.* This court held that *Allied* should have appealed from the Commission’s adoption of the ALJ’s findings. *Id.* at 984. The court so held because

had the President approved the exclusion order, Allied would have prevailed as to that patent and could not have appealed. *Id.* at 983. Likewise, had the President not approved of the exclusion order, Allied could not have appealed the President's decision. *Id.* Thus, "[t]hat determination was final as of [the date the Commission adopted the ALJ's findings], there being no provision for Presidential review, or for other administrative proceedings, following a determination that does not lead to an exclusion order." *Id.* at 984.

*Broadcom* was factually analogous. There, Qualcomm asserted that Broadcom appealed too early, because it did not wait for the Presidential review period to pass. *Broadcom*, 542 F.3d at 896. This court disagreed and held that Broadcom did not prematurely file an appeal. *Id.* at 897.

Here, unlike in *Broadcom* or *Allied*, the Commission issued a *Notice to Review* certain issues of the *Initial Determination*. *Cf. Broadcom*, 542 F.3d at 896; *Allied*, 782 F.2d at 983. Also, unlike in *Broadcom* or *Allied*, Tessera filed its appeal within sixty days of the Commission's *Final Determination*. *Cf. Broadcom*, 542 F.3d at 896; *Allied*, 782 F.2d at 983. Finally, here, unlike in *Broadcom* or *Allied*, whether Tessera could obtain an exclusion order on the '106 patent was still before the Commission. *Cf. Broadcom*, 542 F.3d at 896; *Allied*, 782 F.2d at 983. Had Tessera appealed from the Commission's *Notice to Review*, Tessera would still have been unable to obtain an exclusion order until, at the earliest, the Commission finished its review of the ALJ's findings on claim construction and infringement. *See, e.g., Vast-fame Camera, Ltd. v. Int'l Trade Comm'n*, 56 Fed. App'x 494, 495 (Fed. Cir. 2003) (dismissing some appeals as premature and staying others where a notice of appeal was filed immediately after notice that the ITC would partially review an initial determination).

For the foregoing reasons, this court agrees with Tessera that this court possesses jurisdiction over the Commission's patent exhaustion determination. Under the Commission's own regulations, the *Initial Determination* did not become final because the *Notice to Review* ordered review of certain issues therein pertaining to the '106 patent. 19 C.F.R. § 210.42(h)(2). Until the Commission had rendered a final determination or appealable order, this court lacked jurisdiction. The Commission's *Final Determination* issued on December 29, 2009. Tessera filed a timely notice of appeal on January 28, 2010, within sixty days from that date.

## 2. Exhaustion

Tessera argues that the Commission improperly found patent exhaustion without an authorized sale. Tessera contends that under the terms of the TCC Licenses, sales by its licensees are not licensed, and are therefore unauthorized until royalties have been paid. Because royalties were not paid or were paid late by some licensees, Tessera asserts that sales by those licensees did not trigger exhaustion of its patent rights. Noting that patent exhaustion is designed to prevent a double recovery, Tessera asserts that a finding of patent exhaustion here would deprive it from receiving even a single recovery.

The Commission and Elpida respond that patent exhaustion is triggered "by a sale *authorized* by the patent holder." *Quanta Computer, Inc. v. LG Elecs., Inc.*, 553 U.S. 617, 636 (2008). They argue that Tessera authorized these sales when it granted its TCC Licensees the authority to sell and whether or not Tessera's licensees are current on their royalty payments or were late in making payments has nothing to do with whether the sales were initially authorized by Tessera. The Commission and Elpida further contend that as far as Tessera's ability to

obtain a single recovery is concerned, Tessera still may pursue any number of other avenues to enforce its contractual right to receive royalties. These include an action for breach of contract or arbitration.

“The longstanding doctrine of patent exhaustion provides that the initial authorized sale of a patented item terminates all patent rights to that item.” *Quanta*, 553 U.S. at 625. At issue here, as in *Quanta*, is whether the patentee has authorized certain sales of products embodying the asserted patent. *Id.* at 636. In *Quanta*, patent holder LG licensed a portfolio of patents to Intel. *Id.* at 623. Under the License Agreement, Intel could sell its own products practicing the LG patents. *Id.* The License Agreement did not, however, grant Intel the right to practice the patents in conjunction with non-Intel products. *Id.* *Quanta* purchased, from Intel, products substantially embodying the LG patents and combined them with non-Intel products to practice the licensed patents. *Id.*

The Supreme Court held that LG’s patent rights were exhausted upon Intel’s authorized sale to *Quanta*. Although Intel was not licensed to practice the patents using non-Intel parts, “[n]othing in the License Agreement restricts Intel’s *right to sell* its microprocessors and chipsets to purchasers who intend to combine them with non-Intel parts.” *Id.* at 636 (emphasis added). Rather, the agreement “broadly permit[ted]” Intel to make, use, or sell products free of LG’s patent claims. *Id.* Indeed, the agreement “authorized Intel to sell products that practiced the [asserted patents]. No conditions limited Intel’s *authority to sell* products substantially embodying the patents.” *Id.* at 637 (emphasis added). Because Intel was authorized to sell its products to *Quanta*, the doctrine of patent exhaustion prevented LG from further asserting its patent rights against those products purchased from Intel. *Id.*

Here, as in *Quanta*, Tessera's licensees were authorized to sell the accused products. Nothing in the TCC Licenses limited the licensee's ability to sell the accused products. Each of the TCC License agreements contains an unconditional grant of a license "to sell . . . and/or offer for sale" the accused products. These agreements call for running royalty obligations which accrue on products sold. In some cases, the payments are not due to Tessera until the end of a reporting period. Consequently, in some cases, royalty obligations do not accrue until eight months after the licensed products are sold. But there is nothing in any of the license agreements to even remotely suggest that the existence of a condition subsequent, namely, the payment of royalties, operates to convert initial authorized sales into unauthorized sales for purposes of patent exhaustion.

Tessera spends considerable time arguing about the effect of the "Exclusion for License" provision in the TCC Licenses and the fact that the grant clause quoted above was "[s]ubject to . . . Licensee's payment of the fees and royalties . . . ." These arguments add unnecessary complexity to a rather straightforward analysis. The proper focus is on whether the sales were authorized. Tessera overlooks important aspects of the structure of its TCC Licenses. These agreements expressly authorize licensees to sell the licensed products and to pay up at the end of the reporting period. Thus, in these agreements, Tessera authorizes its licensees to sell the licensed products on credit and pay later. That some licensees subsequently renege or fall behind on their royalty payments does not convert a once authorized sale into a non-authorized sale. Any subsequent non-payment of royalty obligations arising under the TCC Licenses would give rise to a dispute with Tessera's licensees, not with its licensees' customers.

Tessera's argument that the sale is initially unauthorized until it receives the royalty payment is hollow and unpersuasive. The parties do not dispute that the TCC Licenses permit a licensee to sell licensed products before that licensee pays royalties to Tessera. But according to Tessera, that licensee's sale, permitted under the TCC License, would later become unauthorized if that licensee somehow defaulted on a subsequently due royalty payment. That absurd result would cast a cloud of uncertainty over every sale, and every product in the possession of a customer of the licensee, and would be wholly inconsistent with the fundamental purpose of patent exhaustion—to prohibit postsale restrictions on the use of a patented article. *See, e.g., Bloomer v. McQuewan*, 55 U.S. (14 How.) 539, 549 (1852) (stating “when the machine passes to the hands of the purchaser, it is no longer within the limits of the monopoly”).

Finally Tessera challenges the ALJ's finding that Elpida purchased 100% of its accused products from Tessera's licensees. Tessera complains that two of Elpida's suppliers, both of which are affiliates of Tessera's licensees, were not licensed under the TCC Licenses and that there is no evidence they agreed to the terms of the TCC License in writing. Elpida responds that a written acceptance was not necessary, and besides, these suppliers packaged products accused of infringing only the '977 and '627 patents, not the '106 patent. Tessera has no response in its reply brief and fails to point to any contrary record evidence. This court sees no basis on which to overturn the Commission's finding that 100% of Elpida's purchases of products accused of infringing the '106 patent were from Tessera's licensees.

Thus, this court affirms the Commission's determination that Tessera's patent rights are exhausted as to all products accused of infringing the '106 patent purchased from Tessera's licensees. Because Elpida's  $\mu$ BGA prod-

ucts are the only accused products found to infringe the '106 patent, and Elpida acquired 100% of its accused  $\mu$ BGA products from TCC Licensees, patent exhaustion serves as a complete defense for Elpida.

#### F. The '977 and '627 Patents

The Commission found no violation of section 337 with regard to the '977 and '627 patents because of its finding of non-infringement. Both patents have since expired. Because the ITC has a limited statutory mandate and can only issue an exclusion order barring future conduct, nothing remains before the Commission with respect to the '977 and '627 patents. Accordingly, the portion of the appeal pertaining to the '977 and '627 patents is now moot. *Tex. Instruments, Inc. v. Int'l Trade Comm'n*, 851 F.2d 342, 344 (Fed. Cir. 1988).

Tessera requests that this court not only dismiss the appeal as moot but also vacate the Commission's determinations regarding the '977 and '627 patents. Intervenor respondents respond that this court should do no more than dismiss Tessera's appeal as to these patents because Tessera caused the mootness by choosing to bring the action so close to patent expiration. We are not persuaded by Intervenor's argument. It is apparent that this appeal became moot through happenstance, not of Tessera's voluntary actions. *See Tafas v. Kappos*, 586 F.3d 1369, 1371 (Fed. Cir. 2009) ("*Vacatur* . . . is appropriate if the mootness arises from external causes over which the parties have no control" (citing *U.S. Bancorp Mortg. Co. v. Bonner Mall P'ship*, 513 U.S. 18 (1994))). That being the case, we therefore hold moot that portion of the appeal directed to the '977 and '627 patents, vacate that portion of the Commission's *Final Determination* relating to the '977 and '627 patents, and remand with instructions to dismiss as moot the portion of the complaint relating to those patents.



## CONCLUSION

Based on the foregoing, this court finds that the Commission provided a sufficient basis for finding no section 337 violation and its actions were not arbitrary, capricious, an abuse of discretion, or otherwise not in accordance with law. Because the Commission's decision regarding the '106 patent was supported by substantial evidence and contained no errors of law, this court affirms that portion of the *Final Determination*. Because the '977 and '627 patents have now expired, this court vacates that portion of the *Final Determination* and remands with instructions to dismiss as moot the portion of the complaint relating to those patents.

**AFFIRMED-IN-PART, VACATED-IN-PART, AND  
REMANDED**

## COSTS

This court awards costs to Intervenor.